

Specifications

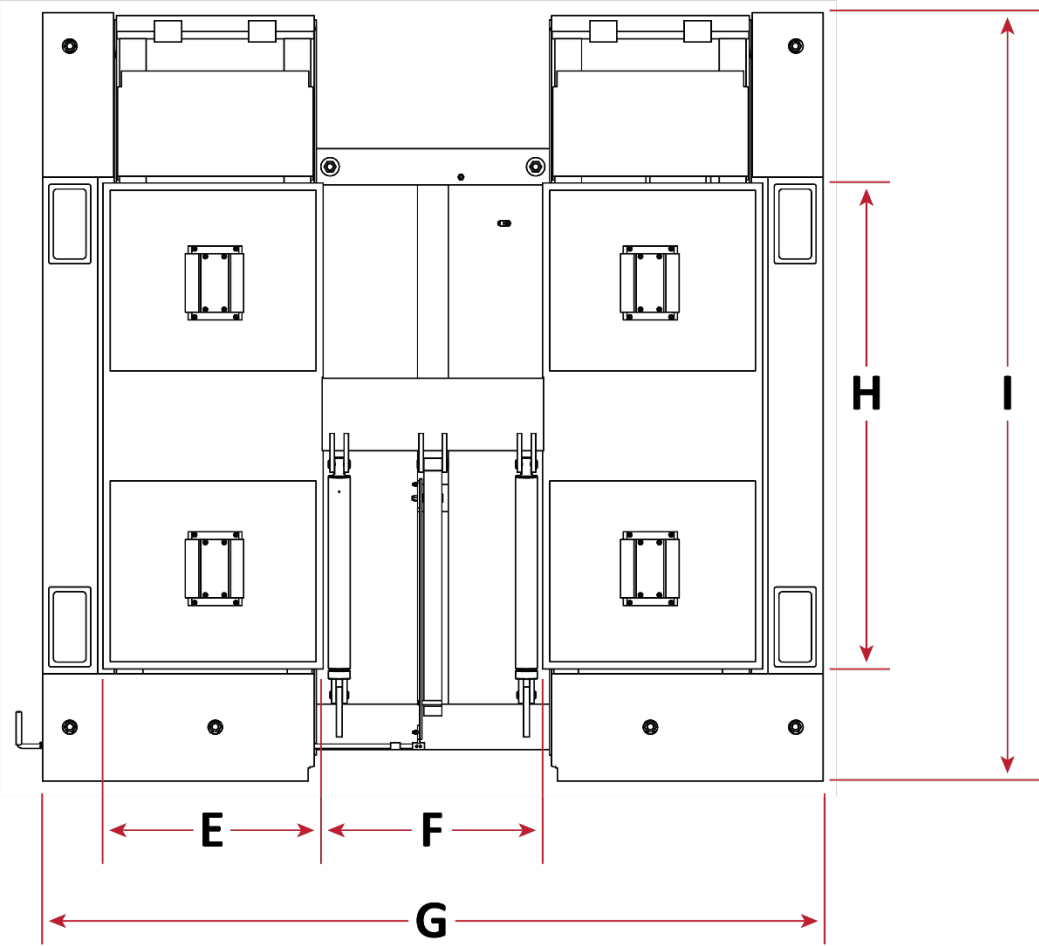
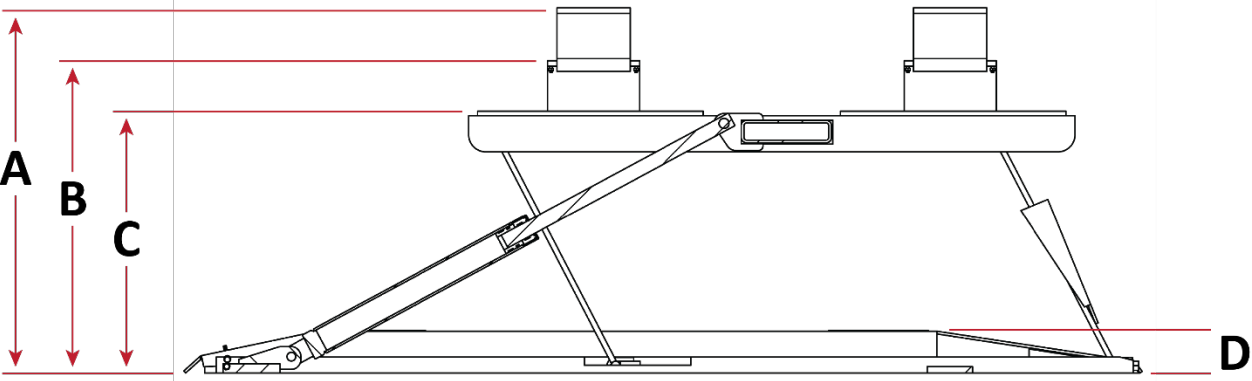

Model	LR-10000
Lifting capacity	10,000 lbs. / 4,536 kg
A Lift height w/Lift Pad and Extension	31.75" / 808 mm
B Lift height w/Lift Pad	27.25" / 692 mm
C Lift height	22.75" / 580 mm
D Lowered height	4.35" / 111 mm
E Platform width	24" / 610 mm
F Width between platforms	24" / 608 mm
G Overall width	85" / 2,162 mm
H Platform length	53" / 1,344 mm
I Overall length	83.5" / 2,124 mm
Maximum hydraulic pressure	2,650 PSI
Lifting time	~35 seconds
Motor	208 – 240 VAC, 50/60 Hz, 1 Ph

Specifications subject to change without notice.