

# INSTALLATION INSTRUCTIONS

## LED HOOD SCOOPS



### APPLICATION:

Jeep Wrangler JL 2dr/Wrangler JL Unlimited 4dr 2018-2020 (Excl Sport, Sport S & Sahara); Gladiator 2020 (Excl. Sport, Sport S, Overland, North Edition)

### PART NUMBER:

62-41115

CONTENT			
ITEM	QUANTITY	DESCRIPTION	TOOLS NEEDED
1	1	DRIVER HOOD SCOOP	10MM SOCKET
2	1	PASSENGER HOOD SCOOP	RATCHET
3	2	LED LIGHT	TORQUE WRENCH
4	1	LED WIRING HARNESS	WIRE STRIPPERS
5	4	CLAMP	PHILLIPS SCREW-DRIVER/ TRIM REMOVAL TOOL
6	1	DRIVER HOOD SCOOP GASKET	
7	1	PASSENGER HOOD SCOOP GASKET	
8	8	M6 HEX HEAD BOLT	
9	8	M6 FLAT WASHER	
10	8	M6 SERRATED FLANGE NUT	
11	4	M4 SERRATED FLANGE NUT	
12	4	RED BUTT CONNECTOR	
13	10	ZIP TIE	

**ANTI-SEIZE LUBRICANT MUST BE USED ON ALL STAINLESS STEEL FASTENERS TO PREVENT THREAD DAMAGE AND GALLING**

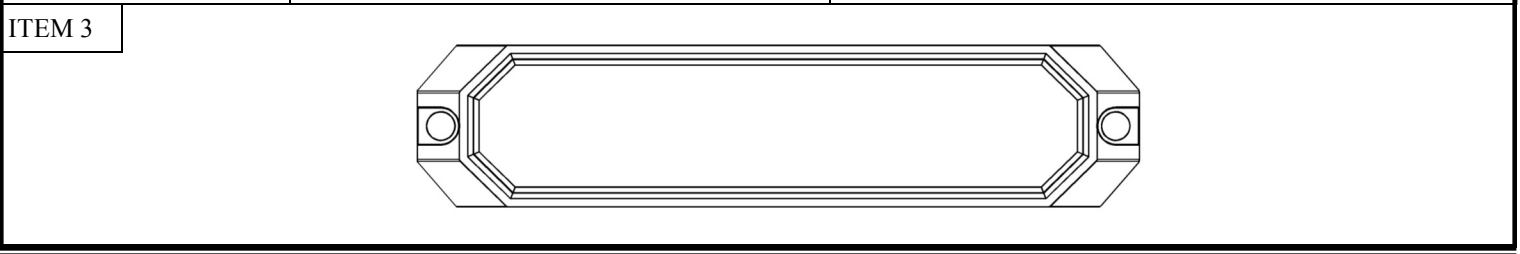
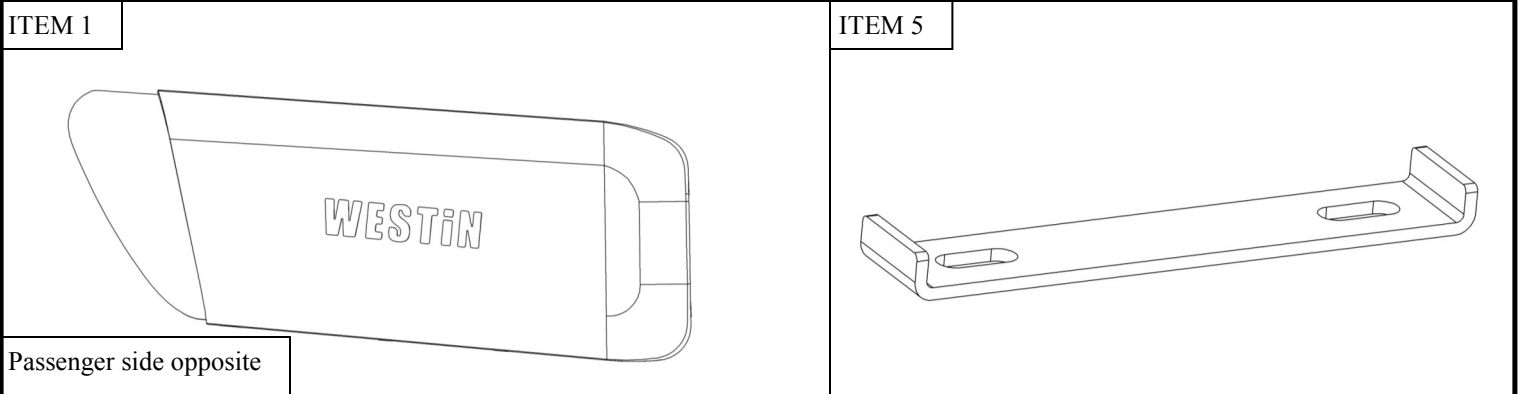

**WESTiN** Westin Automotive Products, Inc.  
320 W. Covina Blvd  
San Dimas, Ca. 91773

Thank you for choosing Westin products  
for additional installation assistance please call  
Customer Service (800) 793-7846

[www.westinautomotive.com](http://www.westinautomotive.com)

## PROCEDURE

1. Remove contents from box, verify if all parts listed are present and free from damage.  
Carefully read and understand all instructions before attempting installation.  
**Failure to identify damage before installation could lead to a rejection of any claim.**

2. Pop the hood open of your vehicle. Then disconnect the negative battery terminal from your battery.
3. You will need to carefully remove the heat shield by removing the trim pieces with a trim removal tool. **See Figure 1.**

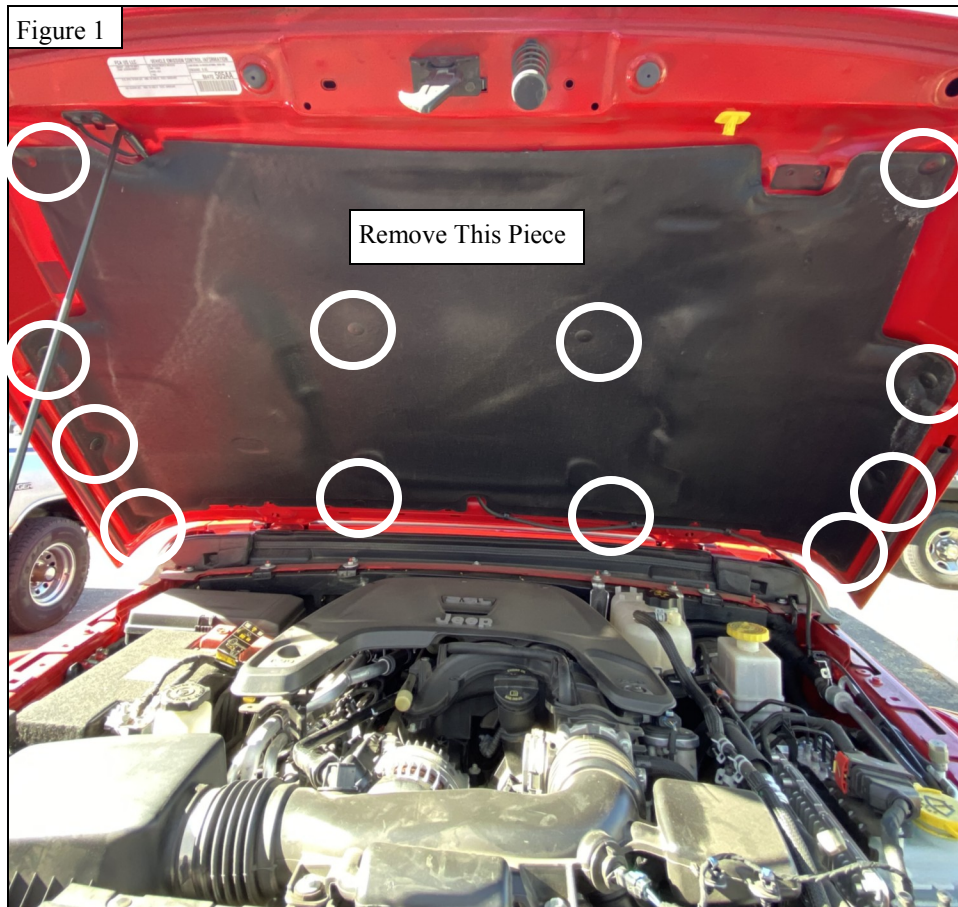

4. Remove the factory hood louvers by pushing on the clips holding it to the hood. **Note: Have another person on the other side holding the piece so that it does not slide down and damage the hood.** See Figure 2-3



5. Locate the light pods. Using the supplied M4 Phillips bolts in the light box and the supplied M4 serrated flange nut (item 11), assemble the light to the hood scoop. Tighten the M4 hardware to 25 in-lbs. See Figure 4. **Note: Disregard the extra M4 hex nut in the light box as it is not needed.**

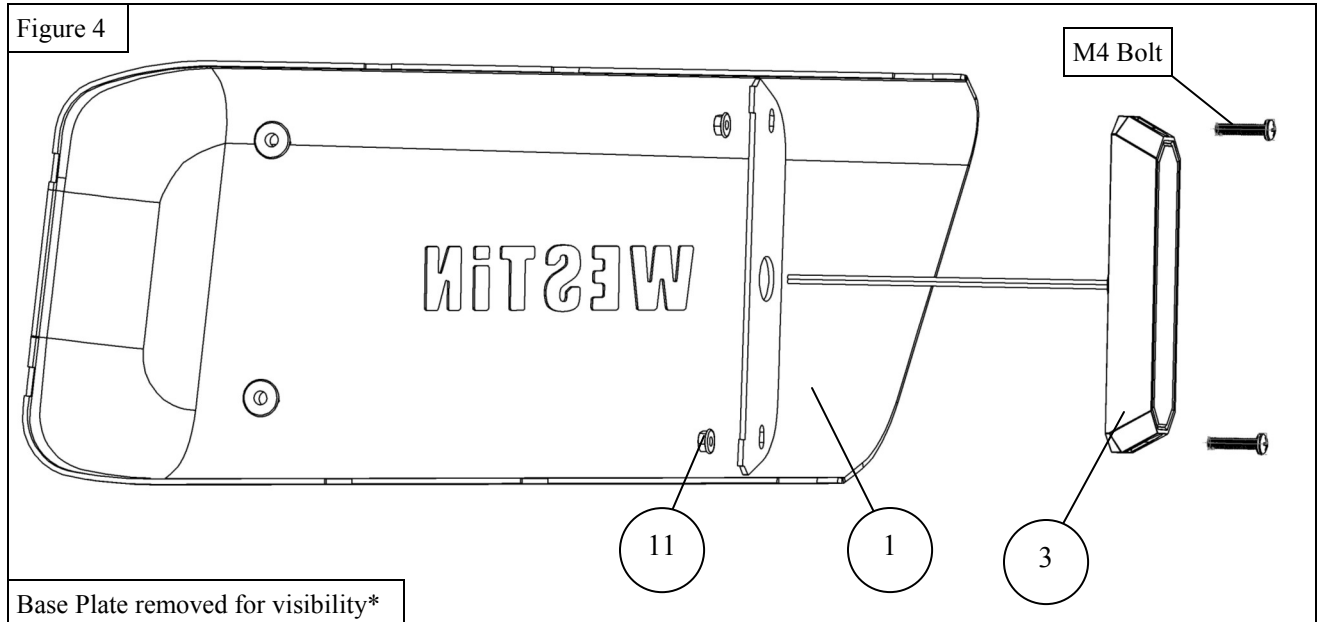

6. Locate the driver and passenger gaskets (items 6-7). Peel back the cover tape and stick the gasket on to each of the hood scoops. See **Figure 5**.

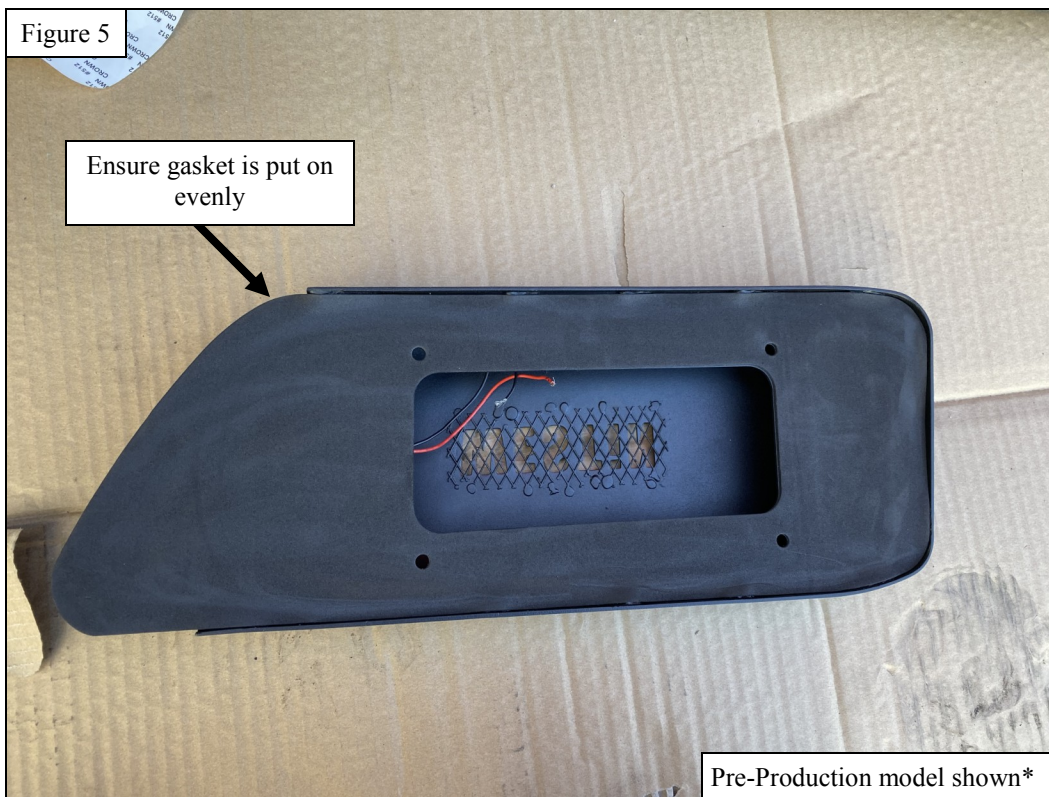

7. Using the supplied M6 hardware and clamps, loosely clamp down the light pods to the hood. See **Figures 6-7**

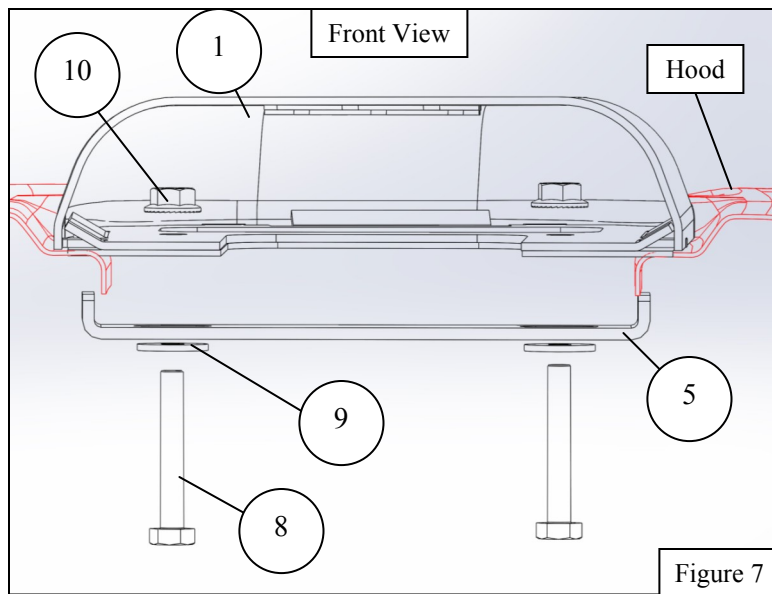
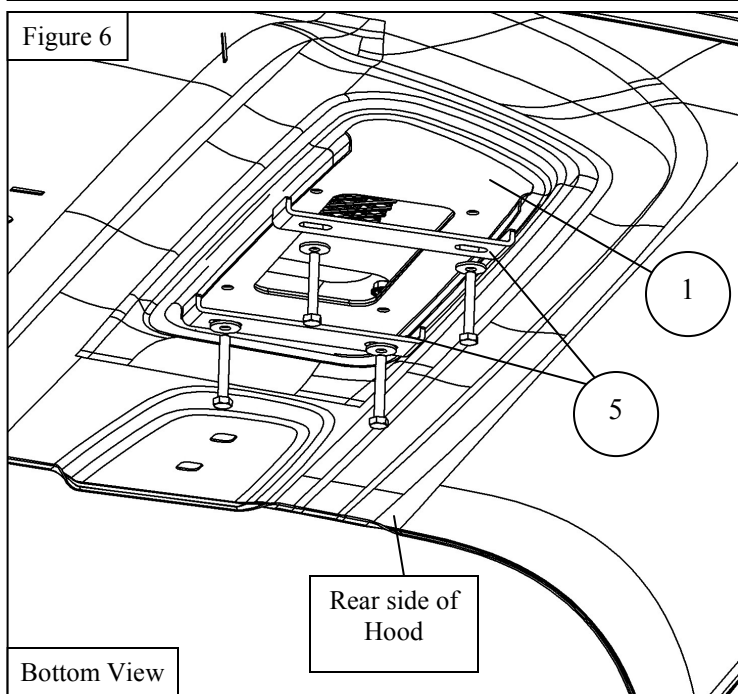

8. Adjust the hood scoops as needed and torque all the M6 hardware to 7-8 ft lbs. Re-torque hardware occasionally as needed.
9. Replace the heat shield by popping back in the trim pieces after wiring the lights.

## LIGHT WIRING INSTALLATION

There are 2 methods to wire up the lights to your vehicle;

1. **Using the supplied switch**– Run the wiring harness along the hood and firewall using the supplied zip ties. You will need to find an access point in the firewall to put the (Switch) wiring harness through. You will have to cut the 2 plugs that will run to the light pods. Using the supplied red butt connectors, crimp each end of the power leads to the light pod wires (red to red) (black to black). Then connect the main power leads to the battery and grounds to a chassis ground. **See Method 1**
2. **Using the factory auxiliary switches**- Run the wiring harness along the hood and firewall using the supplied zip ties. You will have to cut the 2 plugs that will run to the light pods. Using the supplied red butt connectors, crimp each end of the power leads to the light pod wires (red to red) (black to black). In between the battery and passenger inner fender you will find factory auxiliary power supply wires. Open up the wire loom and select a wire to run power from. Since you are using factory wiring, remove Westin's supplied relay, fuse, and switch from the harness. Run the ground wire to a chassis ground. Then connect the main power leads to the battery. **See Method 2 below**

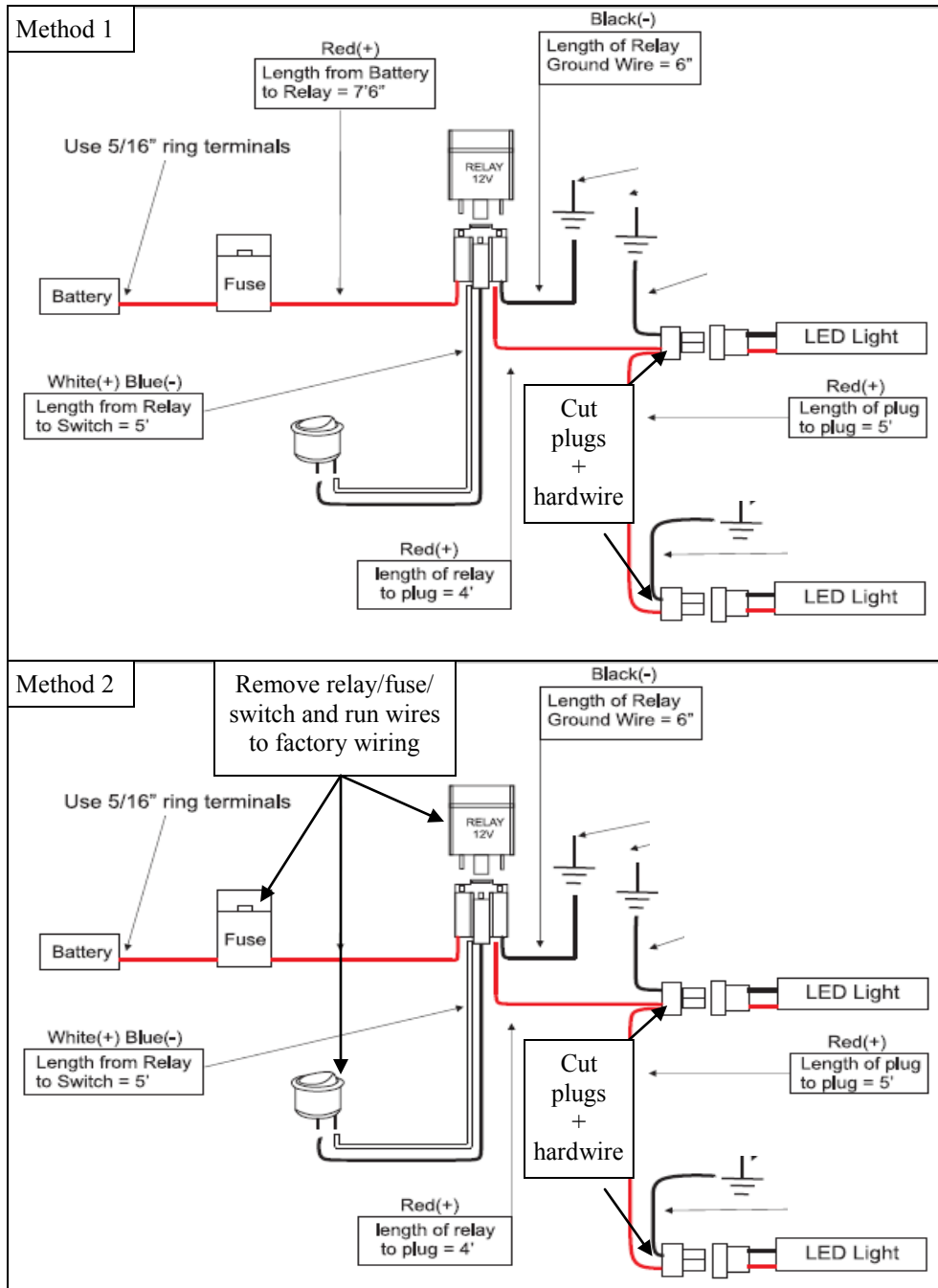

**INSTALLATION COMPLETED**



**CARE INSTRUCTIONS**

- REGULAR WAXING IS RECOMMENDED. DO NOT USE ANY TYPE OF POLISH OR WAX THAT MAY CONTAIN ABRASIVES.
- STAINLESS STEEL PRODUCTS CAN BE CLEANED WITH MILD SOAP AND WATER. STAINLESS STEEL POLISH SHOULD BE USED TO POLISH SMALL SCRATCHES.
- GLOSS BLACK FINISHES SHOULD BE CLEANED WITH MILD SOAP AND WATER.



Westin Automotive Products, Inc.  
320 W. Covina Blvd  
San Dimas, Ca. 91773

Thank you for choosing Westin products  
for additional installation assistance please call  
Customer Service (800) 793-7846  
[www.westinautomotive.com](http://www.westinautomotive.com)



## WARNING



Failure to follow these instructions could lead to death, personal injury, and / or property damage.

Failure to follow these instructions could lead to death, personal injury, and / or property damage.

### FASTENERS:

All Westin supplied fasteners must be utilized and installed in accordance with the installation instructions and apply torque to the specifications as defined. **DOUBLE CHECK ALL FASTENERS BEFORE INITIAL USE, AND PERIODICALLY IN THE FUTURE TO ENSURE PROPER FUNCTION AND SAFETY.**

### DRILLING:

Most Westin products do not require drilling for installation. If drilling is defined as required, use caution when drilling a vehicle. **FAILURE TO REVIEW AN AREA TO BE DRILLED MAY RESULT IN PERSONAL INJURY AND/OR INJURY TO OTHERS AS WELL AS VEHICLE DAMAGE.**

### EYE PROTECTION:

**ALWAYS WEAR SAFETY GLASSES OR GOGGLES DURING THE INSTALLATION PROCESS TO AVOID PERSONAL INJURY.**

### MAXIMUM TOWING/CARRYING CAPACITY: (if applicable)

The Westin Receiver Hitches will have a visible tow rating label affixed directly on the product. User should never exceed the vehicle manufacturers maximum tow and weight rating regardless of the capacity of the hitch. **FAILURE TO FOLLOW THESE GUIDELINES WILL VOID THE WESTIN WARRANTY AND MAY RESULT IN PERSONAL INJURY AND/OR INJURY TO OTHERS AS WELL AS VEHICLE DAMAGE.**

### FOR CALIFORNIA RESIDENTS ONLY-PROP 65 WARNING:

Some products may contain chemicals such as DEHP, which can cause cancer, birth defects or other reproductive harm. For more info go to [www.p65warnings.ca.gov](http://www.p65warnings.ca.gov)



Westin Automotive Products, Inc.  
320 W. Covina Blvd  
San Dimas, Ca. 91773