

# INSTALLATION INSTRUCTIONS

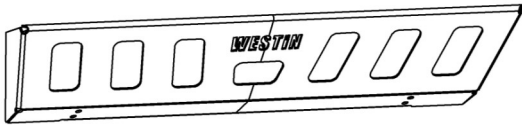
## WJ2 FRONT BUMPER SKID PLATE



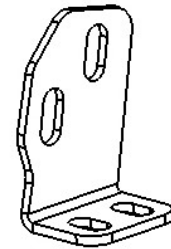
**APPLICATION:**  
2018-2019 Jeep Wrangler JL, 2020 Gladiator  
**PART NUMBER:**  
59-80095

| CONTENT |          |                                 |               |
|---------|----------|---------------------------------|---------------|
| ITEM    | QUANTITY | DESCRIPTION                     | TOOLS NEEDED  |
| 1       | 1        | SKID PLATE                      | 16MM SOCKET   |
| 2       | 2        | MOUNTING BRACKETS               | 16MM WRENCH   |
| 3       | 4        | M8 HEX HEAD FLANGE BOLT         | RATCHET       |
| 4       | 8        | M8 SERRATED FLANGE NUT          | TORQUE WRENCH |
| 5       | 4        | SHORT M8 HEX HEAD CAP SCREW     | ALLEN WRENCH  |
| 6       | 6        | M8 HEX SOCKET BUTTON HEAD SCREW |               |
| 7       | 6        | LARGE M8 FLAT WASHER            |               |
| 8       | 5        | SMALL M8 FLAT WASHER            |               |
| 9       | 6        | M8 SPLIT LOCK WASHER            |               |
| 10      | 1        | LONG M8 HEX HEAD CAP SCREW      |               |
| 11      | 2        | M8 SPLINED RIVCERT              |               |
| 12      | 4        | M8 HEX RIVCERT                  |               |
| 13      | 1        | UNIVERSAL RIVCERT TOOL          |               |
| 14      | 1        | CLOSE OUT PANEL                 |               |

**ANTI-SEIZE LUBRICANT MUST BE USED ON ALL STAINLESS STEEL FASTENERS TO PREVENT THREAD DAMAGE AND GALLING**



ITEM 1



ITEM 2

Driver's Side Shown, Passenger Side Opposite

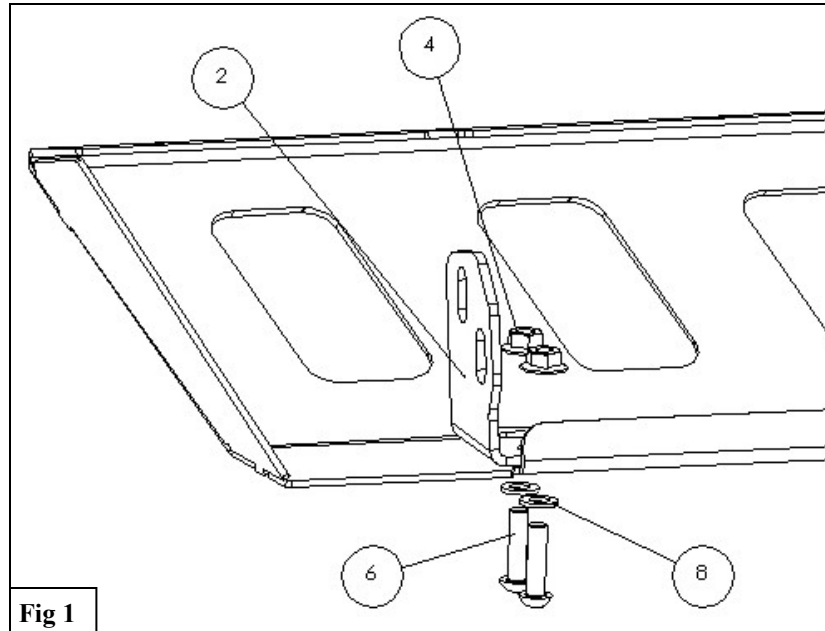
## PROCEDURE

1. Remove contents from box, verify if all parts listed are present and free from damage.

Carefully read and understand all instructions before attempting installation.

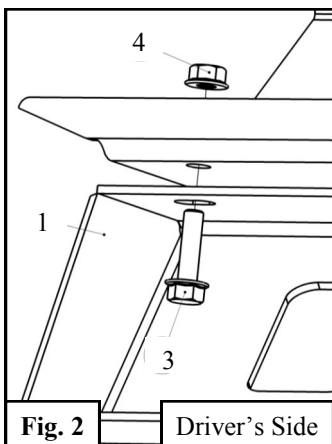
**Failure to identify damage before installation could lead to a rejection of any claim.**

2. Obtain the Skid Plate Mounting Brackets (2) along with the supplied M8 Hardware (3-12).
3. Secure the Skid Plate Mounting Brackets (2) to the Skid Plate Assembly (1) as shown in **Figure 1**.

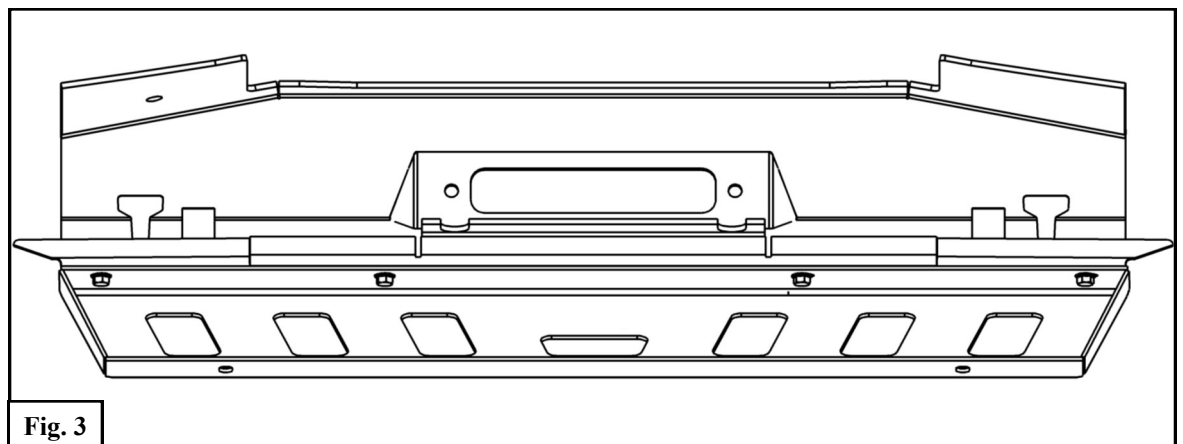


**Fig 1**

4. Loosely install skid (1) plate with the supplied M8 flange bolts (3) and M8 serrated flange nuts (4) according to **Figures 2 & 3**. **Note:** For Rubicon models with auto sway bar disconnect, a wobble socket is recommended to tighten the inner two bolts



**Fig. 2** Driver's Side

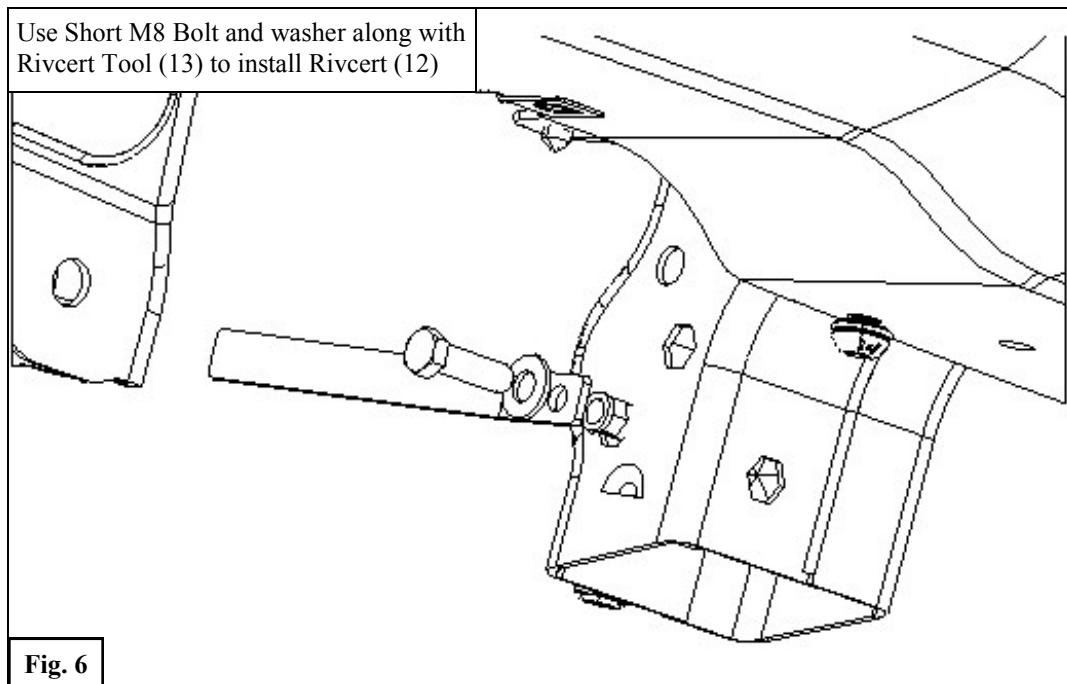
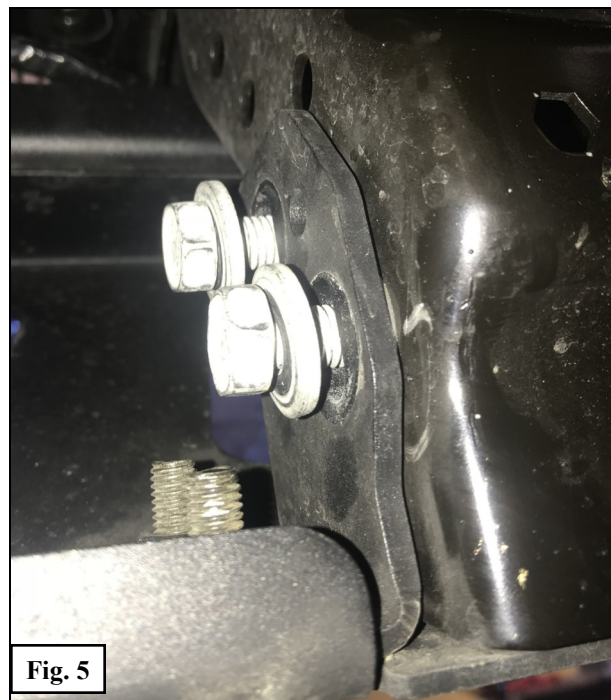
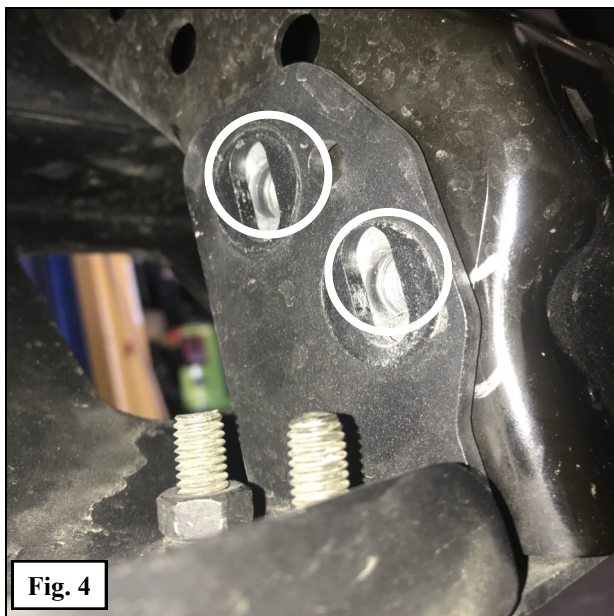


**Fig. 3**

**WESTIN**

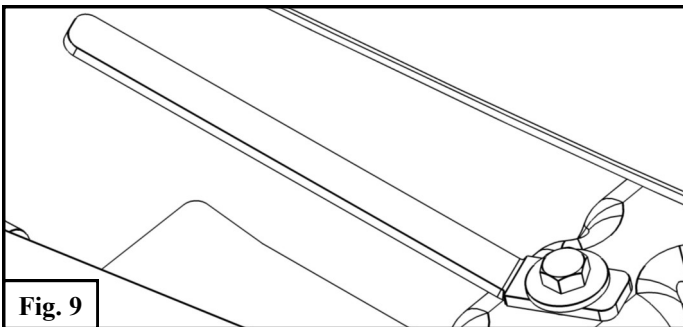
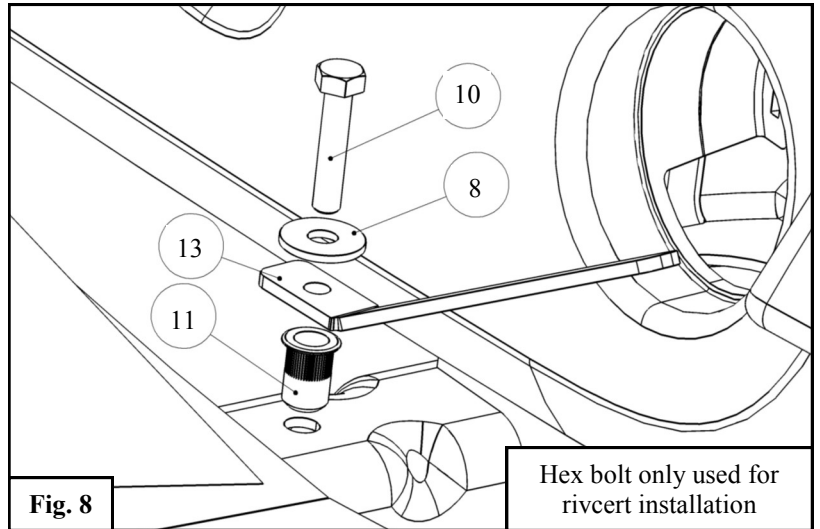
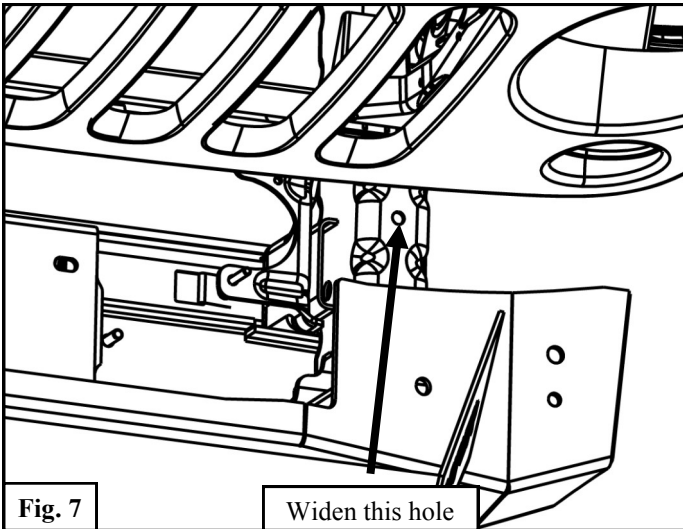
Westin Automotive Products, Inc.  
320 W. Covina Blvd  
San Dimas, Ca. 91773

5. For models with OEM steel bumpers, there will be M10 Hardware with rivcets already in place. See **Figure 4**.
6. In this case, use the OEM bolts to secure the Skid Plate Mounting Bracket to the vehicle. See **Figure 5**.
7. For models with OEM plastic bumpers, the supplied M8 Hex Rivcets (12) will be used along with the supplied short M8 Hex Bolts (5), Flat Washer (7), and Lock Washer (9). See **Figure 6** for Rivcert Installation.

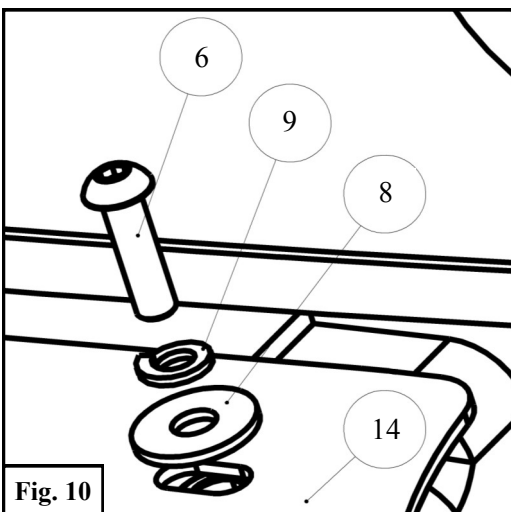


## CLOSE OUT PANEL & RIVCERT INSTALLATION INSTRUCTIONS

- Before installing the close out panel (14), widen the hole in the frame indicated in **Figure 7** to 7/16" with a drill. Repeat procedure on the passenger's side. **Note:** Driver's side is shown.
- Slip an M8 flat washer (8) over the long M8 hex head cap screw (10) and then insert the cap screw into the M8 universal rivcert tool (13). Loosely thread the long M8 hex head cap screw into an M8 splined rivcert (11). See **Figure 8**.
- Insert the M8 rivcert (11) into the driver's side hole widened in step 6 and tighten the M8 hex head cap screw while simultaneously applying pressure with the rivcert tool until there is significant resistance. **Note:** When the rivcert is installed, it will have collapsed and fastened itself to the hole. See **Figure 9**.
- Remove the hex head cap screw, washer, and rivcert tool. Repeat steps 6-8 on the passenger's side of the vehicle.



- Install the close out panel (14) using the supplied M8 button head hardware according to **Figure 10**.



- Adjust bumper and torque all M8 hardware to 18 ft-lbs.

**Installation Complete (Lights, Winch, and Bumper Sold Separately)**



**CARE INSTRUCTIONS**

- REGULAR WAXING IS RECOMMENDED. DO NOT USE ANY TYPE OF POLISH OR WAX THAT MAY CONTAIN ABRASIVES
- STAINLESS STEEL PRODUCTS CAN BE CLEANED WITH MILD SOAP AND WATER. STAINLESS STEEL POLISH SHOULD BE USED TO POLISH SMALL SCRATCHES.
- GLOSS BLACK FINISHES SHOULD BE CLEANED WITH MILD SOAP AND WATER

**WESTIN** Westin Automotive Products, Inc.  
320 W. Covina Blvd  
San Dimas, Ca. 91773

Thank you for choosing Westin products  
for additional installation assistance please call  
Customer Service (800) 793-7846  
[www.westinautomotive.com](http://www.westinautomotive.com)



## WARNING



Failure to follow these instructions could lead to death, personal injury, and / or property damage.

Failure to follow these instructions could lead to death, personal injury, and / or property damage.

### FASTENERS:

All Westin supplied fasteners must be utilized and installed in accordance with the installation instructions and apply torque to the specifications as defined. **DOUBLE CHECK ALL FASTENERS BEFORE INITIAL USE, AND PERIODICALLY IN THE FUTURE TO ENSURE PROPER FUNCTION AND SAFETY.**

### DRILLING:

Most Westin products do not require drilling for installation. If drilling is defined as required, use caution when drilling a vehicle. **FAILURE TO REVIEW AN AREA TO BE DRILLED MAY RESULT IN PERSONAL INJURY AND/OR INJURY TO OTHERS AS WELL AS VEHICLE DAMAGE.**

### EYE PROTECTION:

**ALWAYS WEAR SAFETY GLASSES OR GOGGLES DURING THE INSTALLATION PROCESS TO AVOID PERSONAL INJURY.**

### MAXIMUM TOWING/CARRYING CAPACITY:

The Westin Receiver Hitches will have a visible tow rating label affixed directly on the product. User should never exceed the vehicle manufacturers maximum tow and weight rating regardless of the capacity of the hitch. **FAILURE TO FOLLOW THESE GUIDELINES WILL VOID THE WESTIN WARRANTY AND MAY RESULT IN PERSONAL INJURY AND/OR INJURY TO OTHERS AS WELL AS VEHICLE DAMAGE.**



Westin Automotive Products, Inc.  
320 W. Covina Blvd  
San Dimas, Ca. 91773

Thank you for choosing Westin products  
for additional installation assistance please call  
Customer Service (800) 793-7846  
[www.westinautomotive.com](http://www.westinautomotive.com)