

# INSTALLATION INSTRUCTIONS

## R5 Wheel to Wheel Nerf Step Bars



**APPLICATION:**  
2016-2019 Toyota Tacoma Double Cab (6 ft. Bed)  
**PART NUMBER:**  
28-534180, 28-534185

CONTENT			
ITEM	QUANTITY	DESCRIPTION	TOOLS NEEDED
1	2	STEP BAR ASSEMBLY FRONT SECTION (1 DRIVER, 1 PASSENGER)	18MM SOCKET
2	2	STEP BAR ASSEMBLY REAR SECTION (1 DRIVER, 1 PASSENGER)	18MM WRENCH
3	2	STEP PAD	16MM SOCKET
4	2	LINK BRACKET (1 DRIVER, 1 PASSENGER)	16MM WRENCH
5	2	LINK PLATE	13MM WRENCH
6	2	TALL REINFORCEMENT LINK	10MM WRENCH
7	2	SHORT REINFORCEMENT LINK	10MM SOCKET
8	2	FRONT MOUNTING BRACKET (1 DRIVER, 1 PASSENGER)	RATCHET
9	2	CENTER-REAR MOUNTING BRACKET (1 DRIVER, 1 PASSENGER)	TORQUE WRENCH
10	2	TOP ISOLATOR BRACKET	
11	2	BOTTOM ISOLATOR BRACKET (1 DRIVER, 1 PASSENGER)	
12	2	ISOLATOR KIT	
13	6	PLATE ADAPTER	
14	8	BRACKET COVER	
15	2	M12 NUT PLATE	
16	2	M12 HEX HEAD BOLT SHORT	
17	4	M12 SPLIT LOCK WASHER	
18	2	M12 FLAT WASHER	
19	4	M10 HEX HEAD FLANGE BOLT	
20	12	M8 HEX HEAD CAP SCREW	
21	24	M8 SPLIT LOCK WASHER (12 black zinc)	
22	24	M8 FLAT WASHER (12 black zinc)	
23	12	M8 HEX NUT	
24	28	M6 HEX HEAD CAP SCREW (12 black zinc)	
25	44	M6 FLAT WASHER (12 black zinc)	
26	16	M6 NYLOCK NUT	
27	12	M6 SPLIT LOCK WASHER	
28	16	THREAD CUTTING NUTS	

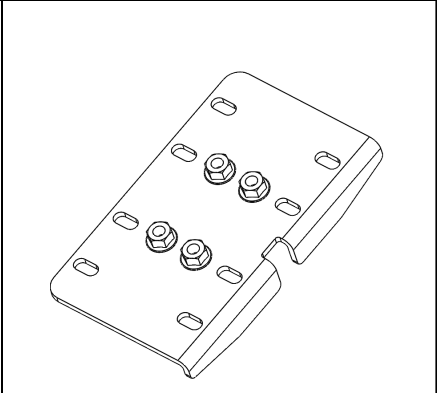
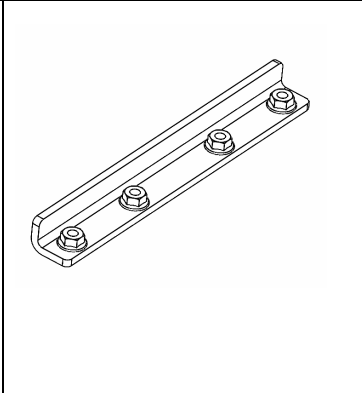
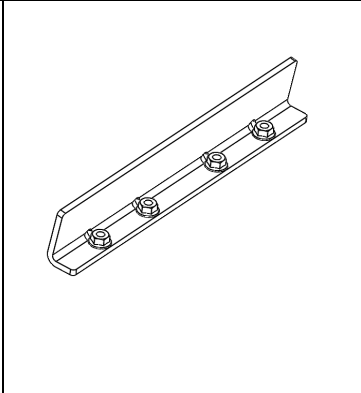
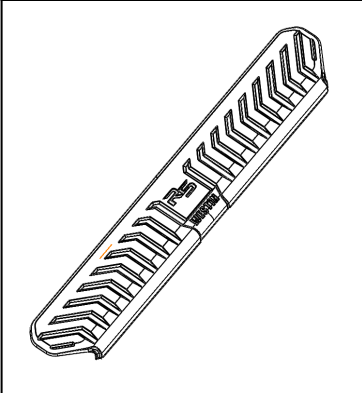
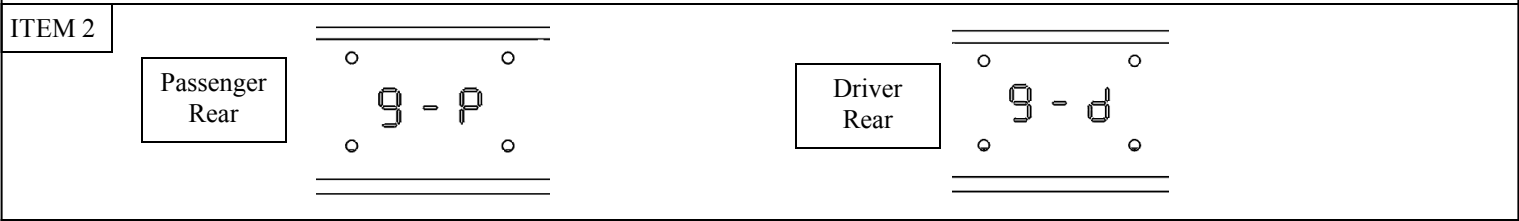
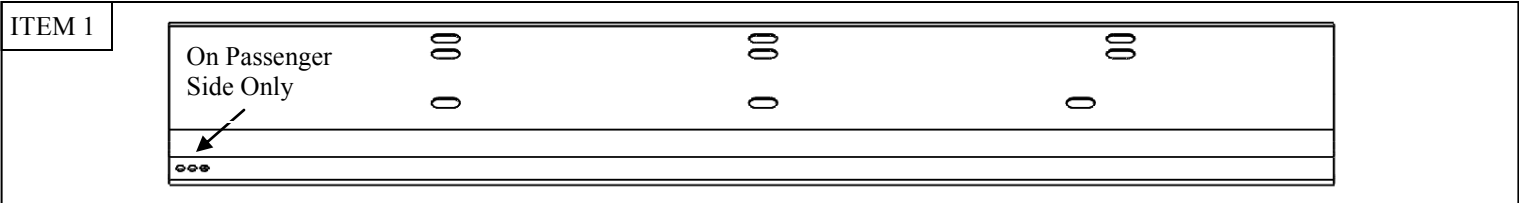

ITEM 3

ITEM 6

ITEM 7

ITEM 5

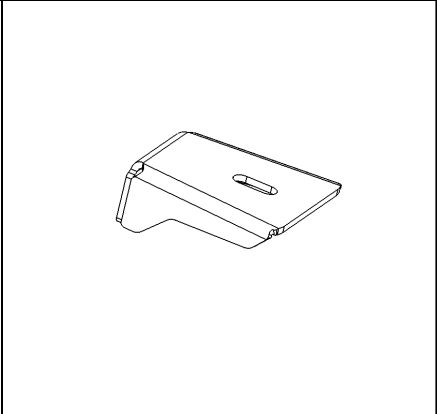
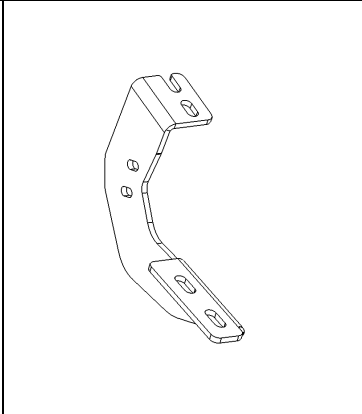
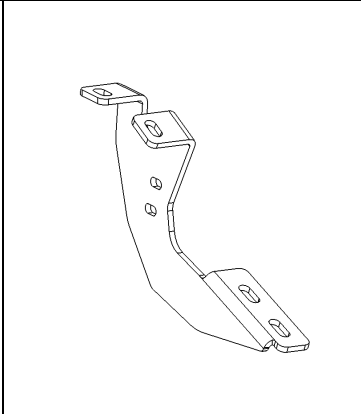
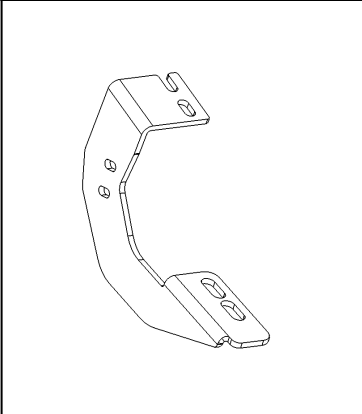

ITEM 4

ITEM 8

ITEM 9

ITEM 10

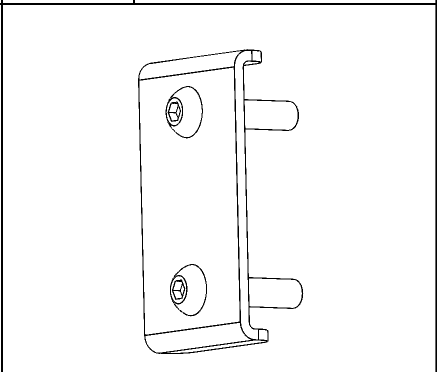
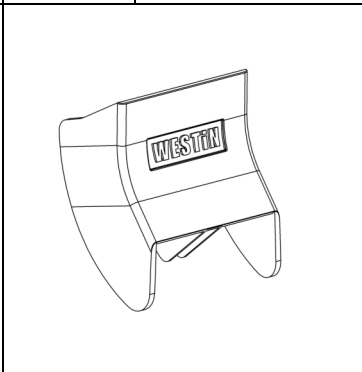
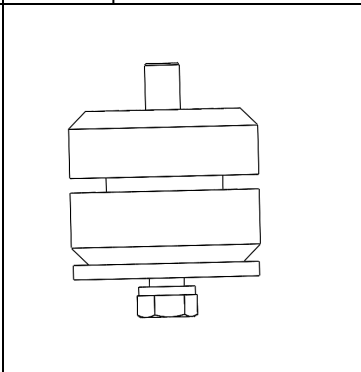
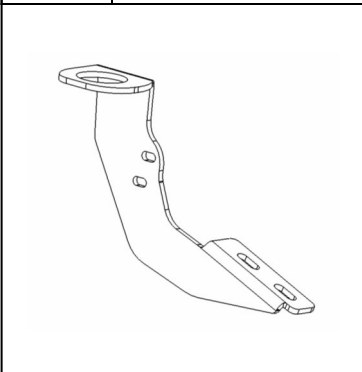

ITEM 11

ITEM 12

ITEM 14

ITEM 13

DRIVER SIDE ITEMS SHOWN

## PROCEDURE

1. Remove contents from box, verify if all parts listed are present and free from damage.

Carefully read and understand all instructions before attempting installation.

**Failure to identify damage before installation could lead to a rejection of any claim.**

2. Start installation on either side of the vehicle. Locate mounting locations with factory threaded holes with caps covering them. Remove factory caps from threaded holes, they will not be used again. Locate (1) Front Mounting Bracket and loosely install it to the front mounting location on the rocker panel using (2) M8 hex head cap screws, (2) M8 split lock washer, and (2) M8 flat washer (Items 20-22). Locate the Link Bracket (Item 4) and loosely secure in the correct mounting locations on the rocker panel. Loosely install using the provided M8 hardware (Items 20-22). **See Figure. 1 and 2.**
3. Repeat Step 2 for the other vehicle side. **Go to page 6 for supplementary bracket configuration diagram.**

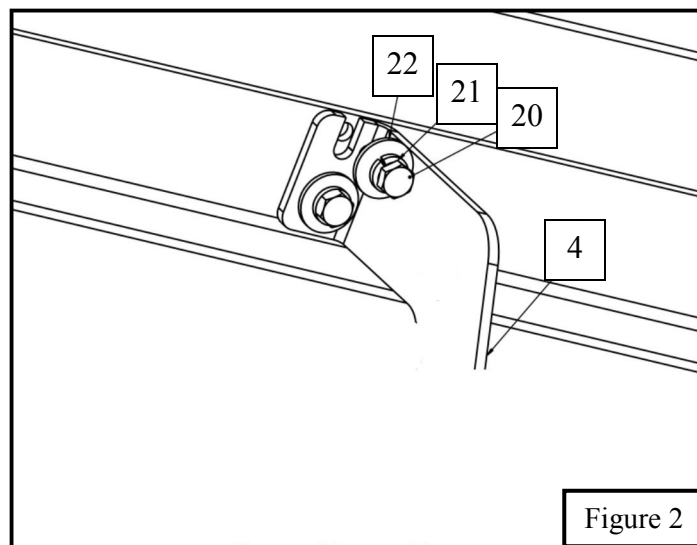
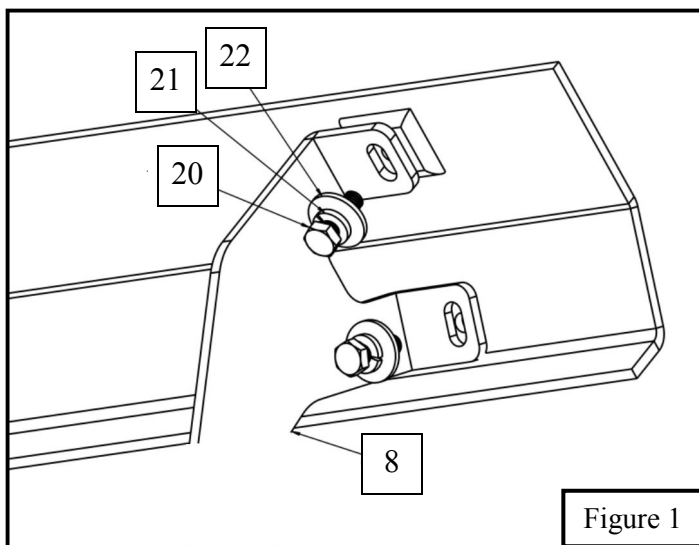

4. On driver side of the truck underneath the bed, locate a part of the frame that protrudes outward and has a large slot on its face. This is where you slide the M12 Nut Plate (item 15) and loosely install the Top Isolator Bracket (Item 10) with the supplied M12 hardware. **See Figure 3**
5. Locate (1) isolator kit (Item 12) and (1) isolator bracket (10/11) and loosely secure each other with the previously installed top isolator bracket. **See Figure 4.**

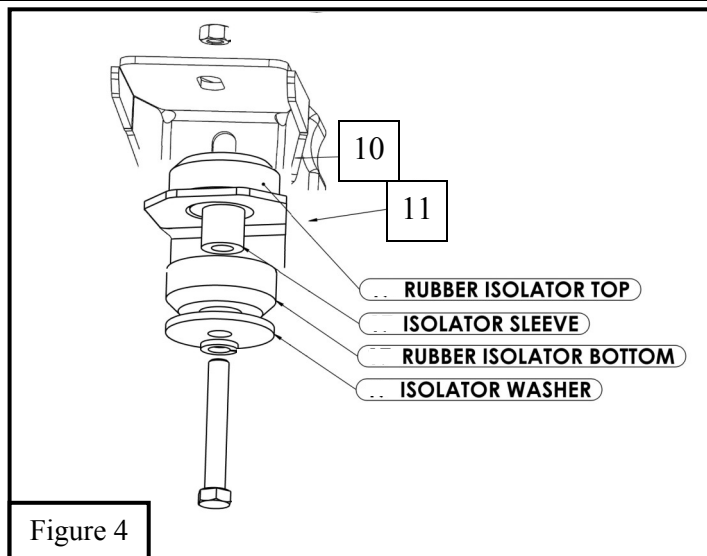
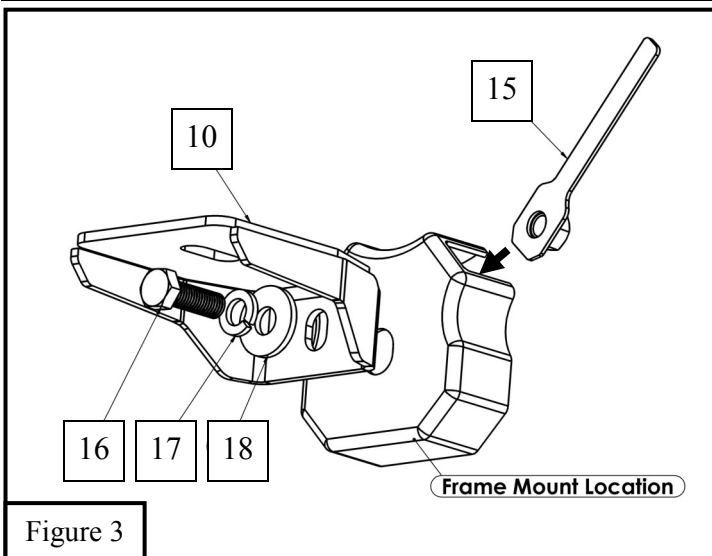

6. Obtain both sections of the Step Bar Assembly (1 or 2). Slide the Reinforcement Links (6 & 7) into both sides of the step bar sections. See **Figure 5**.

7. Line up the holes on the Step Bar sections with the holes on the Reinforcement Links (6 & 7). See **Figure 6**.

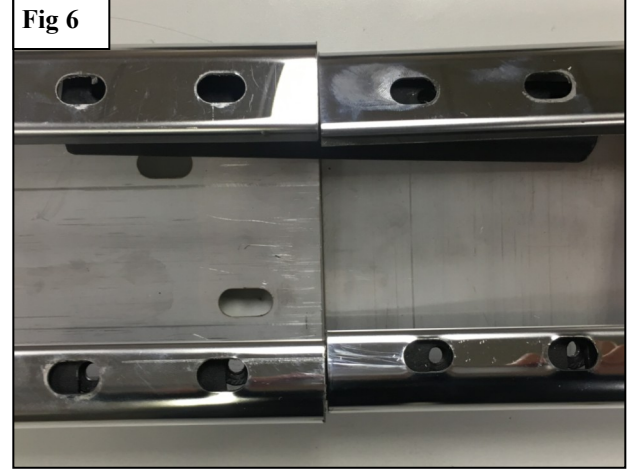

8. Place the supplied step pad into the holes to connect the two Step Bar sections (1 & 2). Place the supplied thread cutting nut (Item 28) on each of the plastic stems. Tighten until nut reaches metal and feels firm in place. See **Figures 7 & 8**.



9. Obtain the Link Plate (5) and secure it to the Step Bar Assembly (1 & 2) using the supplied black M6 Hardware. See Figure 9.

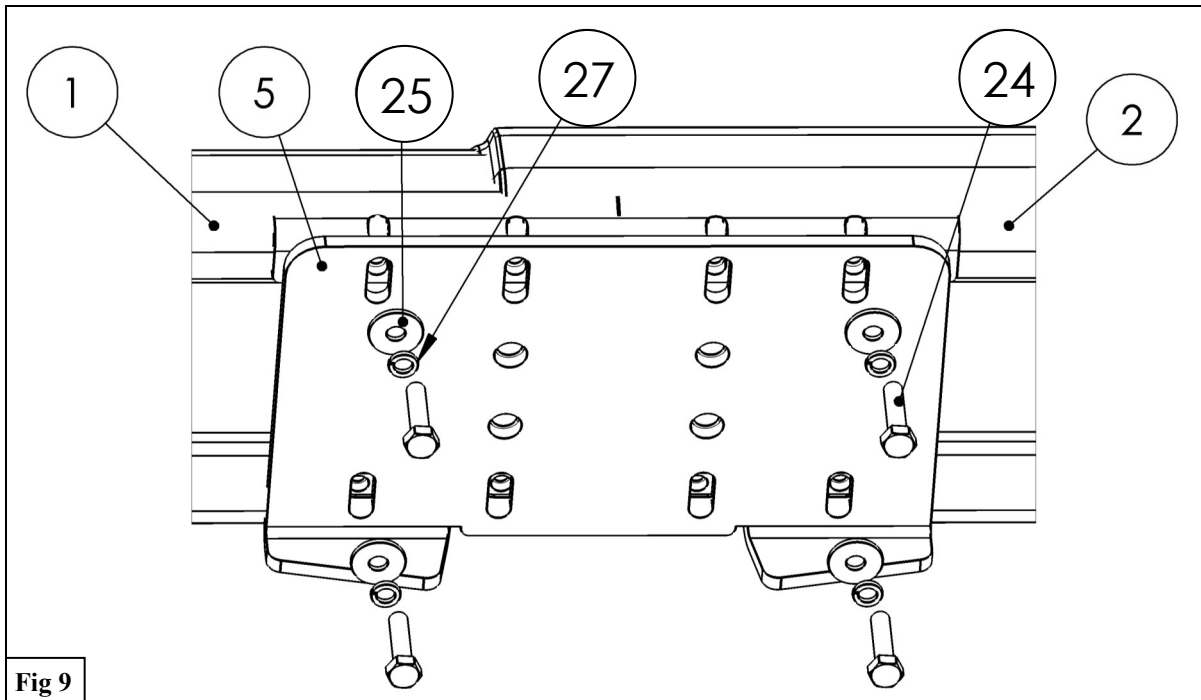

10. Installation of the step boards will utilize the supplied black M8 hardware with Plate Adapters (13) for all brackets excluding the Link Brackets (4). The Link Brackets (4) will use the supplied black M10 hardware. See Figures 10 & 11.

11. To minimize gap between bars, make sure to align and adjust the step bars and brackets as needed, then fully tighten all hardware: M6 to 7-9 ft-lbs. M8 to 15-18 ft-lbs, M10 to 32-38 ft-lbs, and M12 to 52-60 ft-lbs.

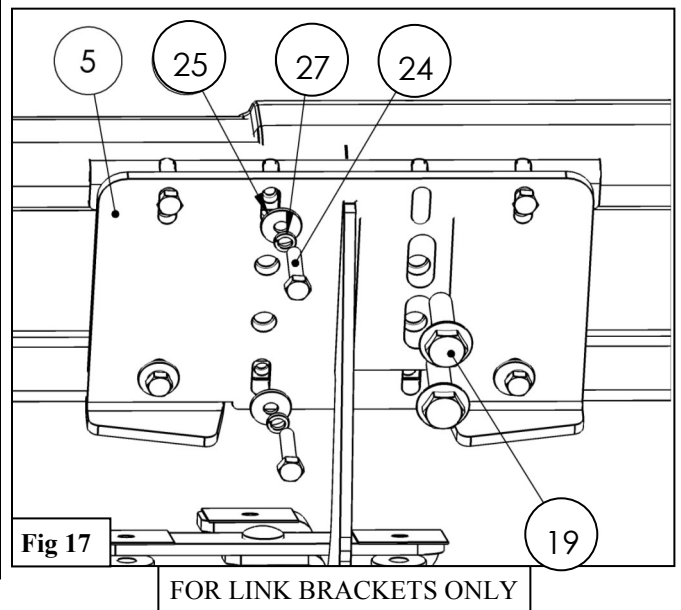
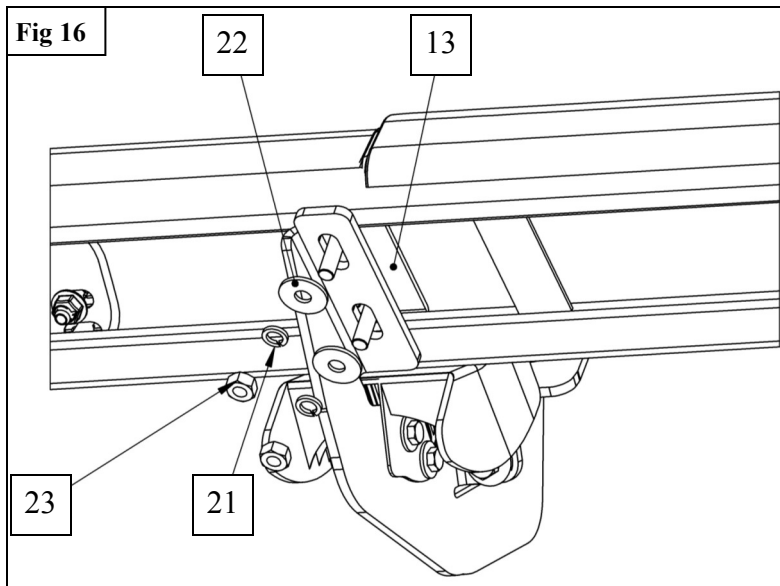

**Plastic Cover Installation:**

1. Locate (1) plastic bracket cover (Item 14) and loosely secure it to the brackets using the provided hardware: (2) M6 hex head cap screws, (4) M6 flat washers, and (2) M6 nylock nuts. Repeat for every bracket. See **Figure 18**.

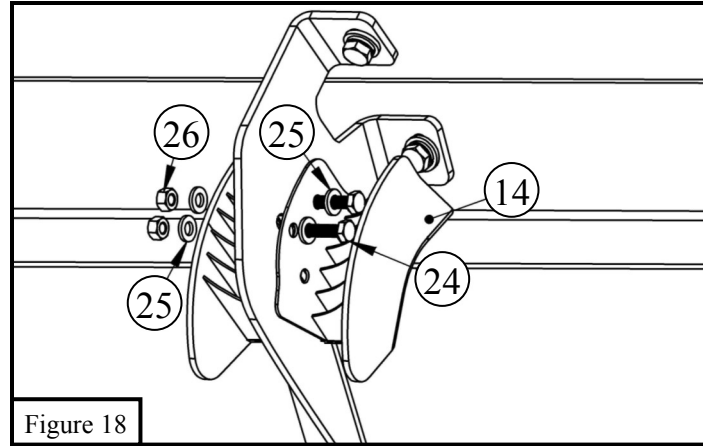

Driver Side Bracket Orientation

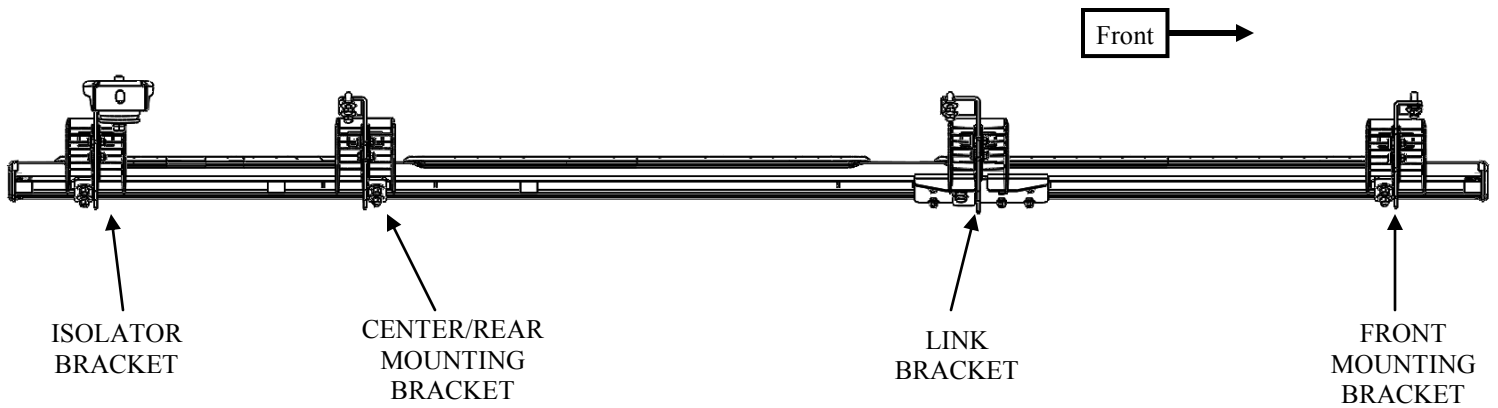

INSTALLATION COMPLETE



**WESTIN** Westin Automotive Products, Inc.  
320 W. Covina Blvd  
San Dimas, Ca. 91773

P.N.: 75-2853418-RevB

ECO #: W18-0125

7

Thank you for choosing Westin products  
for additional installation assistance please call  
Customer Service (800) 793-7846

[www.westinautomotive.com](http://www.westinautomotive.com)

DATE: 10/22/18



## WARNING



Failure to follow these instructions could lead to death, personal injury, and / or property damage.

Failure to follow these instructions could lead to death, personal injury, and / or property damage.

### FASTENERS:

All Westin supplied fasteners must be utilized and installed in accordance with the installation instructions and apply torque to the specifications as defined. **DOUBLE CHECK ALL FASTENERS BEFORE INITIAL USE, AND PERIODICALLY IN THE FUTURE TO ENSURE PROPER FUNCTION AND SAFETY.**

### DRILLING:

Most Westin products do not require drilling for installation. If drilling is defined as required, use caution when drilling a vehicle. **FAILURE TO REVIEW AN AREA TO BE DRILLED MAY RESULT IN PERSONAL INJURY AND/OR INJURY TO OTHERS AS WELL AS VEHICLE DAMAGE.**

### EYE PROTECTION:

**ALWAYS WEAR SAFETY GLASSES OR GOGGLES DURING THE INSTALLATION PROCESS TO AVOID PERSONAL INJURY.**

### MAXIMUM TOWING/CARRYING CAPACITY:

The Westin Receiver Hitches will have a visible tow rating label affixed directly on the product. User should never exceed the vehicle manufacturers maximum tow and weight rating regardless of the capacity of the hitch. **FAILURE TO FOLLOW THESE GUIDELINES WILL VOID THE WESTIN WARRANTY AND MAY RESULT IN PERSONAL INJURY AND/OR INJURY TO OTHERS AS WELL AS VEHICLE DAMAGE.**



Westin Automotive Products, Inc.  
320 W. Covina Blvd  
San Dimas, Ca. 91773

Thank you for choosing Westin products  
for additional installation assistance please call  
Customer Service (800) 793-7846  
[www.westinautomotive.com](http://www.westinautomotive.com)