

**PARTS LIST:**

1	Rear Bumper	16	12mm x 24mm OD x 2.5mm Flat Washers
1	Passenger Side Mounting Bracket	6	12mm Nylon Lock Nuts
1	Driver Side Mounting Bracket	4	12mm Lock Washers
10	12-1.75mm x 35mm Hex Bolts	2	Washer Plates

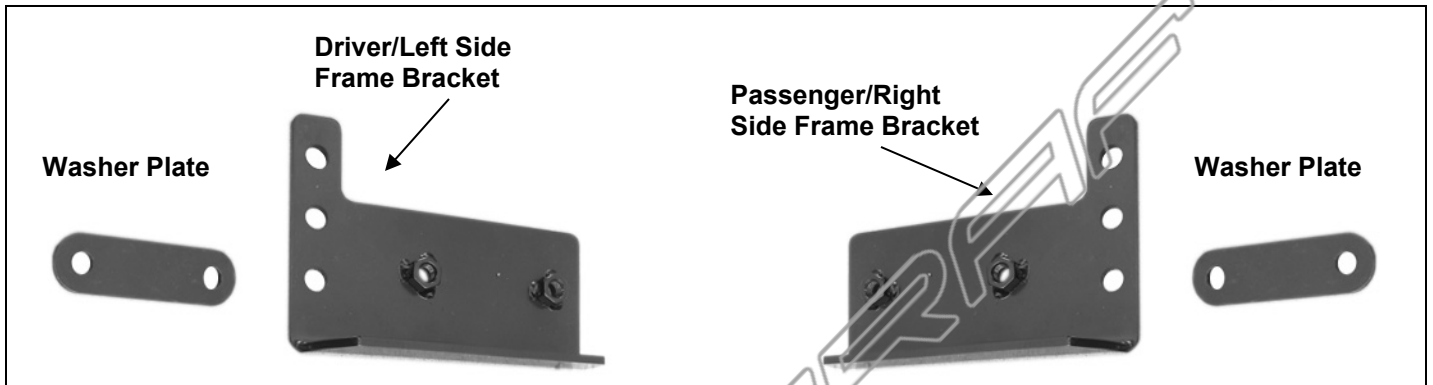

**PROCEDURE:**

- 1. REMOVE CONTENTS FROM BOX. VERIFY ALL PARTS ARE PRESENT. READ INSTRUCTIONS CAREFULLY BEFORE STARTING INSTALLATION. WARNING: ALLOW TIME FOR THE MUFFLER TO COMPLETELY COOL BEFORE REMOVING REAR BUMPER OR INSTALLING REAR BUMPER BRACKETS.**
- Remove the factory bumper by removing the side brackets, **(Figure 1)**, and the two inner brackets behind the factory bumper, **(Figure 2)**.
- Insert the Driver Side Mounting Bracket into frame channel and line up threaded weldnuts with holes in side of frame, **(Figure 3)**.
- Position Washer Plate on the outside of the frame, **(Figure 4)**. Align holes on the Washer Plate with holes on the frame and the Mounting Bracket. Bolt the Bracket in position with the included (2) 12mm x 30mm Hex Bolts, (2) Lock Washers, and (2) 12mm Flat Washers, **(Figure 4)**. Do not tighten hardware at this time.
- Repeat **Steps 3 & 4** for passenger side Bracket installation.
- With assistance, carefully position the Rear Bumper up to the outside of the Mounting Brackets. Attach the Bumper to the Brackets with the included (6) 12mm x 30mm Hex Bolts, (12) 12mm Flat Washers and (6) 12mm Nylon Lock Nuts, **(Figure 5)**. Do not tighten hardware at this time. **NOTE:** Cover the factory hitch, (if equipped), with a piece of cardboard or masking tape to protect the finish on the Rear Bumper during installation.
- Level and adjust the Rear Bumper and tighten all hardware at this time. **NOTE:** If vehicle is equipped with factory tow hitch, leave a 1/4" gap between the Rear Bumper and the hitch.
- Do periodic inspections to the installation to make sure that all hardware is secure and tight.

**To protect your investment**, wax this product after installing. Regular waxing is recommended to add a protective layer over the finish. Do not use any type of polish or wax that may contain abrasives that could damage the finish.

**For stainless steel:** Aluminum polish may be used to polish small scratches and scuffs on the finish. Mild soap may be used also to clean the Bumper.

**For gloss black finishes:** Mild soap may be used to clean Bumper.

### Driver Side Installation Pictured

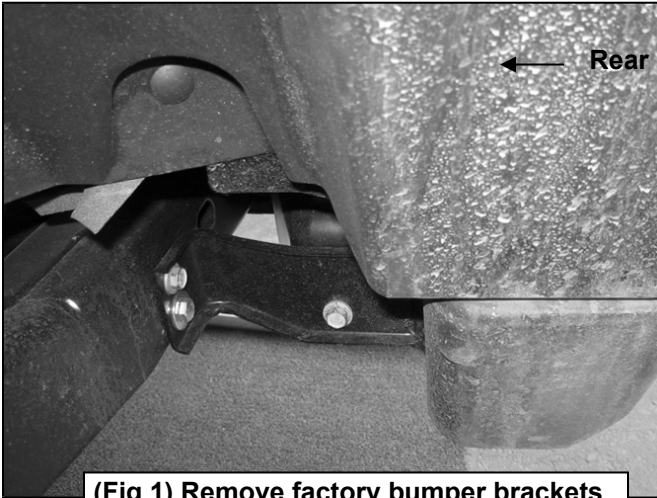

(Fig 1) Remove factory bumper brackets  
(Driver side pictured)

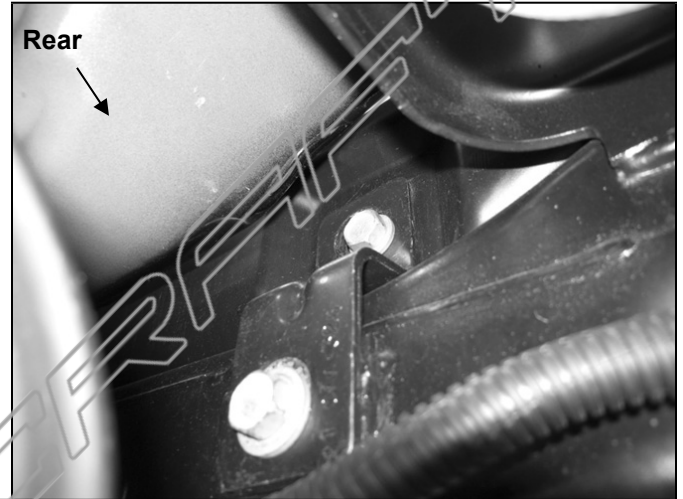

(Fig 2) Remove center mounting bolts behind bumper

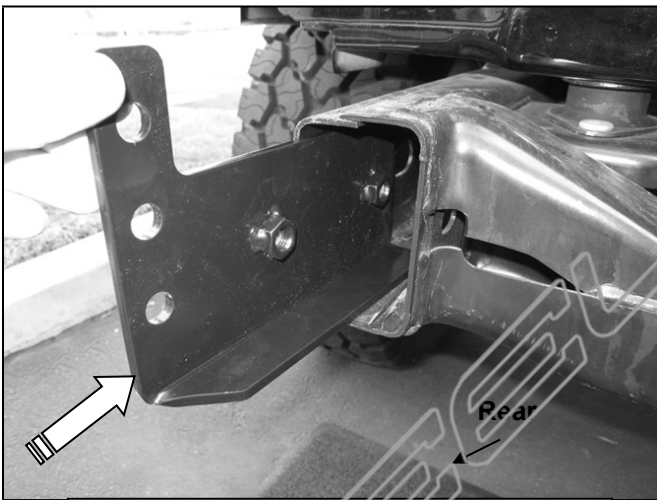

(Fig 3) Insert Bracket into frame channel  
(Driver side pictured)

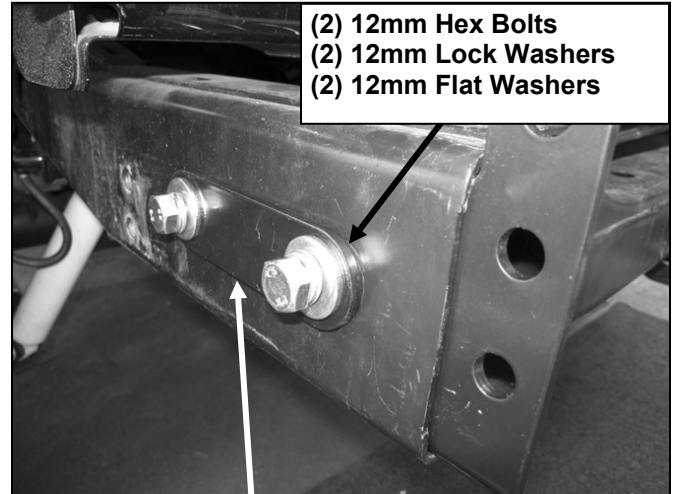

(Fig 4) Use Spacer Washer to cover openings in  
side of frame channel (Driver side pictured)

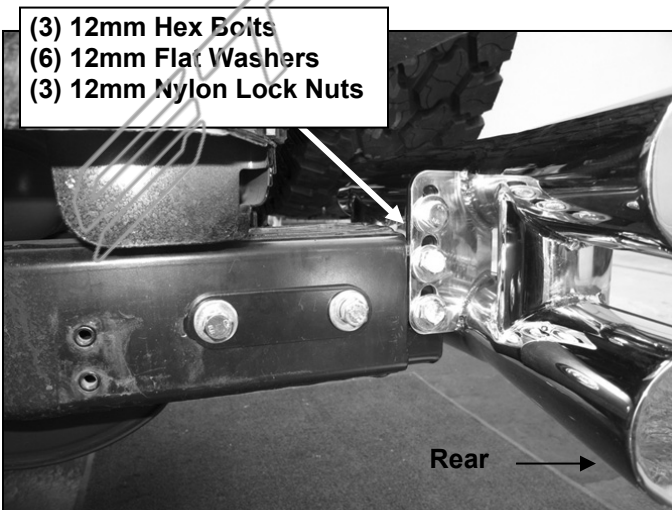

(Fig 4) Driver side Bracket installation pictured