



2020-2021 C8 Corvette WinMax/ProMax Wiring Harness

PART NUMBER: 12-10119-WFR

PART NUMBER: 12-10119-PFR

INSTALLATION INSTRUCTIONS

This Nitrous Outlet Vehicle Specific Harness is designed specifically for the 2020 and up Chevrolet Corvette with an LT2 engine. If you need any assistance during installation or if you have questions about this wiring harness, call our Tech Help Line at (254) 848-4300.

Tools Needed for Installation*:

- 7mm Socket
- 10mm Socket
- 13mm Socket
- 15mm Socket
- 21mm Socket
- T-15 Torx Bit
- T-30 Torx Bit
- Ratchet
- 12" Extension
- 1" Hole Saw
- 2" Hole Saw
- Drill
- Trim Tool

Additional Materials Needed for Installation:

- Electrical Tape
- Lifting Blocks
- Floor Jack
- Jack Puck
- Wiring Materials

***These are the tools required for installation of this kit on a stock vehicle. If your vehicle has aftermarket parts, other tools may be required.**



Step 1 – Disconnect the Battery

- Open the front storage compartment.



- Remove the trim panels on each side of the vehicle by pulling them from the clips securing them to the body.



- Remove the cowl panel covering the battery by pulling it from the clips securing it to the body.



- Using 10mm socket, loosen the nut and remove the negative battery terminal.

IMPORTANT: All appropriate safety equipment (gloves, tools etc.) must be used during the installation of this product(s).

Nitro Dave's LLC accepts NO responsibility for injuries or damages resulting during and/or from the installation of any product(s). Nitrous oxide is for off-road use only.

WWW.NITROUSOUTLET.COM/INSTALLATION-GUIDES



2020-2021 C8 Corvette WinMax/ProMax Wiring Harness

PART NUMBER: 12-10119-WFR

PART NUMBER: 12-10119-PFR

INSTALLATION INSTRUCTIONS



- Remove the cover over the positive terminal and remove the nut from the terminal with a 10mm deep socket.



Step 2 – Vehicle Disassembly

FRONT STORAGE COMPARTMENT

- Remove the front trim panel from the front storage area by pulling it from the clips securing it to the body.



- Using a T-30 Torx bit, remove the 4 screws from the front storage bin.



- Unscrew the 2 rear tabs holding the storage net.



- Unplug the front storage light/power port connector.

IMPORTANT: All appropriate safety equipment (gloves, tools etc.) must be used during the installation of this product(s).

Nitro Dave's LLC accepts NO responsibility for injuries or damages resulting during and/or from the installation of any product(s). Nitrous oxide is for off-road use only.

WWW.NITROUSOUTLET.COM/INSTALLATION-GUIDES



2020-2021 C8 Corvette WinMax/ProMax Wiring Harness

PART NUMBER: 12-10119-WFR

PART NUMBER: 12-10119-PFR

INSTALLATION INSTRUCTIONS



- Remove the front storage bin from the vehicle.

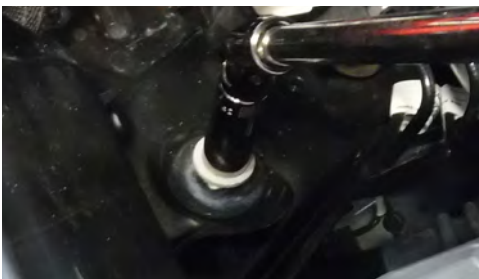

- Using a 13mm socket and 12" extension, remove the bolt under the brake fluid reservoir.



INTERIOR

- Open the driver door.



- Remove the side trim panel from the center console by pulling it away from the console.



- Pull back the carpet on the console between the seat and the accelerator.

IMPORTANT: All appropriate safety equipment (gloves, tools etc.) must be used during the installation of this product(s).

Nitro Dave's LLC accepts NO responsibility for injuries or damages resulting during and/or from the installation of any product(s). Nitrous oxide is for off-road use only.

WWW.NITROUSOUTLET.COM/INSTALLATION-GUIDES



2020-2021 C8 Corvette WinMax/ProMax Wiring Harness

PART NUMBER: 12-10119-WFR

PART NUMBER: 12-10119-PFR

INSTALLATION INSTRUCTIONS



- Remove the aluminum tape covering the hole in the center console.



- Remove the speaker cover at the top of the console between the seats by lifting it up. It will release from the clips securing it to the body.



- Pull the rear console cover forward and it will release from the clips securing it to the body. You must unplug the speaker and phone charger connectors before removing the cover from the vehicle.



- Pull back the carpet covering the interior fuse box.



IMPORTANT: All appropriate safety equipment (gloves, tools etc.) must be used during the installation of this product(s).

Nitro Dave's LLC accepts NO responsibility for injuries or damages resulting during and/or from the installation of any product(s). Nitrous oxide is for off-road use only.

WWW.NITROUSOUTLET.COM/INSTALLATION-GUIDES



2020-2021 C8 Corvette WinMax/ProMax Wiring Harness

PART NUMBER: 12-10119-WFR

PART NUMBER: 12-10119-PFR

INSTALLATION INSTRUCTIONS



- Remove the cover of the interior fuse box.



ENGINE BAY

- Open the engine compartment.



CHASSIS TUNNEL

- You will need to lift the vehicle off the ground to remove the under-car panels. It is recommended to use an automotive lift. For the do-it-yourself install, use a floor jack with a jack puck and place lifting blocks under all 4 tires.



- Locate the center panel that runs the length of the car. At the rear of that panel is a smaller metal panel with 6 bolts. Using a 15mm socket, remove the 4 rear bolts on that panel. Using a 21mm socket, loosen the 2 largest bolts. The panel should slide rearward and drop off the vehicle.



- At the front of the center panel is another small metal panel. Using a 15mm socket, loosen the bolts holding this panel.

IMPORTANT: All appropriate safety equipment (gloves, tools etc.) must be used during the installation of this product(s).

Nitro Dave's LLC accepts NO responsibility for injuries or damages resulting during and/or from the installation of any product(s). Nitrous oxide is for off-road use only.

WWW.NITROUSOUTLET.COM/INSTALLATION-GUIDES



2020-2021 C8 Corvette WinMax/ProMax Wiring Harness

PART NUMBER: 12-10119-WFR

PART NUMBER: 12-10119-PFR

INSTALLATION INSTRUCTIONS



- Using a 13mm socket, remove the bolts from the center panel and remove the panel from the vehicle.



- Using 10mm, 13mm, and 15mm sockets, remove the rear panel from the vehicle.

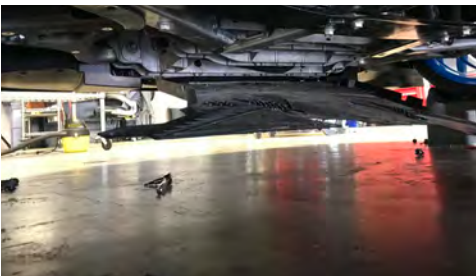

- Using 7mm socket and T-15 Torx, remove the front panel from the vehicle.



Step 3 – Harness Installation

- Place the harness assembly on the ground beside the car. The bottle accessory and fuse panel wiring will run to the front of the vehicle.

ProMax electronics bracket shown.



- In the chassis tunnel, use a 10mm socket and extension to remove the 4 bolts holding the HVAC tubing clamps bolts. You will need these bolts to install the electronics panel.

IMPORTANT: All appropriate safety equipment (gloves, tools etc.) must be used during the installation of this product(s).

Nitro Dave's LLC accepts NO responsibility for injuries or damages resulting during and/or from the installation of any product(s). Nitrous oxide is for off-road use only.

WWW.NITROUSOUTLET.COM/INSTALLATION-GUIDES



2020-2021 C8 Corvette WinMax/ProMax Wiring Harness

PART NUMBER: 12-10119-WFR

PART NUMBER: 12-10119-PFR

INSTALLATION INSTRUCTIONS



- Starting at the center of the tunnel under the car, route the switch panel, controller/display, and 12V Switched wiring through the hole in the driver side of the chassis tunnel.

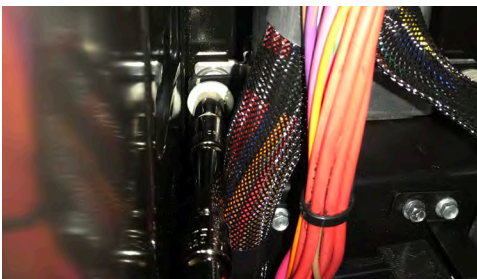

- Using the HVAC clamp OEM hardware (2 steps above), 10mm socket and extension, install the electronics bracket in the chassis tunnel with the controller and relay bracket on the passenger side of the car.



- Route the bottle opener, heater, sensor wiring, fuse panel wiring, and battery connection toward the front of the car beside the HVAC piping.

ProMax electronics bracket shown.



- Pull the harness to the driver side of the car and over the HVAC tubing into the area of the front storage compartment.

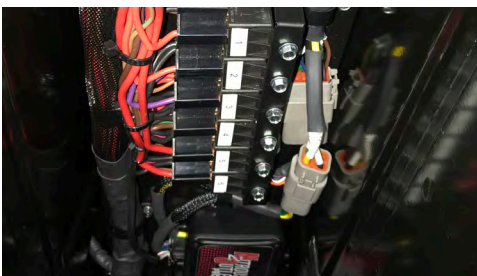

- Route the ECU, dedicated tank, and solenoid wiring to the rear of the car past the ECU and up the firewall.

ProMax electronics bracket shown.

IMPORTANT: All appropriate safety equipment (gloves, tools etc.) must be used during the installation of this product(s).

Nitro Dave's LLC accepts NO responsibility for injuries or damages resulting during and/or from the installation of any product(s). Nitrous oxide is for off-road use only.

WWW.NITROUSOUTLET.COM/INSTALLATION-GUIDES



2020-2021 C8 Corvette WinMax/ProMax Wiring Harness

PART NUMBER: 12-10119-WFR

PART NUMBER: 12-10119-PFR

INSTALLATION INSTRUCTIONS



- Use the installation guide in the back of these instructions to put the connectors on your solenoids. After the connectors are installed, plug them into the leads of the wiring harness. There will be separate leads labeled 'Nitrous', 'Fuel', and 'Purge'.

- Route the wires for the dedicated fuel system up the firewall, through the rear passenger wheelwell, and to the dedicated fuel tank. Use the installation guide in the back of these instructions to put the connector on your fuel pump wires. After the connector is installed, plug them into the connector on the wiring harness.

- On the driver side of the center console compartment, an access hole needs to be placed as far forward and as high as possible. Before drilling, remove the switch panel as not to damage it or any switches. Using a 1" hole saw, drill the access hole.

IMPORTANT: All appropriate safety equipment (gloves, tools etc.) must be used during the installation of this product(s).

Nitro Dave's LLC accepts NO responsibility for injuries or damages resulting during and/or from the installation of any product(s). Nitrous oxide is for off-road use only.

WWW.NITROUSOUTLET.COM/INSTALLATION-GUIDES



2020-2021 C8 Corvette WinMax/ProMax Wiring Harness

PART NUMBER: 12-10119-WFR

PART NUMBER: 12-10119-PFR

INSTALLATION INSTRUCTIONS



- Route the wires for the switch panel along the driver side of the center console, then through the 1" hole and to the back side of the panel, connect them per the harness diagram.



- Without pulling the wires from the switches, pull the wiring through the hole in the side of the console until the switch panel is completely on the bottom of the console. Make sure that the console lid does not activate any of the buttons.



- Route the **ProMax** Controller Display Screen or **WinMax** Controller cable along the console. Using a 1" hole saw, drill an access hole.



ProMax only:

- Route the cables for the ProMax Controller Display Screen along the driver side of the center console, then through the 1" hole and plug it in to the display.



WinMax only:

- Route the WinMax Controller wiring along the driver side of the center console and to the 1" hole. Pull the wiring from the WinMax controller from the inside of the center console, through the 1" hole. Using the provided 22-18GA Brazed Butt Connectors and heat shrink, connect the controller leads to the wiring harness with the diagram below.

IMPORTANT: All appropriate safety equipment (gloves, tools etc.) must be used during the installation of this product(s).

Nitro Dave's LLC accepts NO responsibility for injuries or damages resulting during and/or from the installation of any product(s). Nitrous oxide is for off-road use only.

WWW.NITROUSOUTLET.COM/INSTALLATION-GUIDES



2020-2021 C8 Corvette WinMax/ProMax Wiring Harness

PART NUMBER: 12-10119-WFR

PART NUMBER: 12-10119-PFR

INSTALLATION INSTRUCTIONS

WINMAX CONTROLLER

FROM CONTROLLER		-----CAR HARNESS	
RED WIRE 18GA		12 V ARM SWITCH	16GA ORANGE
BLACK WIRE 18GA		BATTERY GROUND	16GA BLACK
GREY WIRE 18GA		TACH SIGNAL	16GA PURPLE/WHITE
WHITE WIRE 18GA		TPS SIGNAL	16GA GREEN/WHITE
BLUE WIRE 18GA		STAGE 1	16GA GREEN/ORANGE
GREEN WIRE 18GA		TIMING 1 OUTPUT	16 GA WHITE/BLACK
ORANGE WIRE 18GA		STAGE 2	16GA YELLOW/BLUE
YELLOW WIRE 18GA		TIMING 2 OUTPUT	16GA BLUE/RED



- Route the 12v Source wire along the center console, under the carpet, up to the fuse panel.

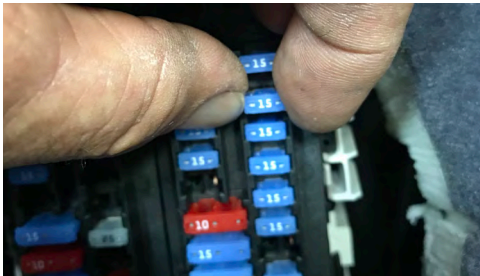

- Remove the 15a fuse in position #2.

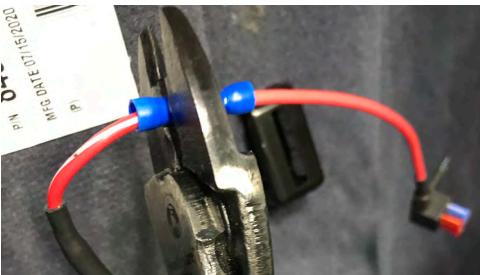

- Using a wire crimper, connect the provided fuse tap to the labeled harness wire.

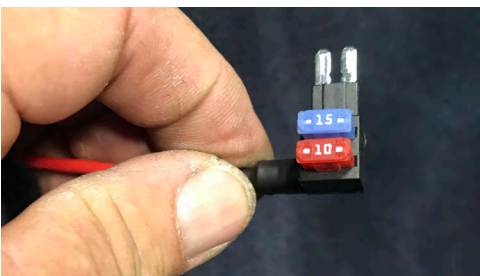

- Insert the OEM 15a fuse into the fuse tap.

IMPORTANT: All appropriate safety equipment (gloves, tools etc.) must be used during the installation of this product(s).

Nitro Dave's LLC accepts NO responsibility for injuries or damages resulting during and/or from the installation of any product(s). Nitrous oxide is for off-road use only.

WWW.NITROUSOUTLET.COM/INSTALLATION-GUIDES



2020-2021 C8 Corvette WinMax/ProMax Wiring Harness

PART NUMBER: 12-10119-WFR

PART NUMBER: 12-10119-PFR

INSTALLATION INSTRUCTIONS



- Insert the fuse tap into position #2 on the fuse panel.

C8 Corvette Fuse Panel Diagram on Bulkhead Between Seats

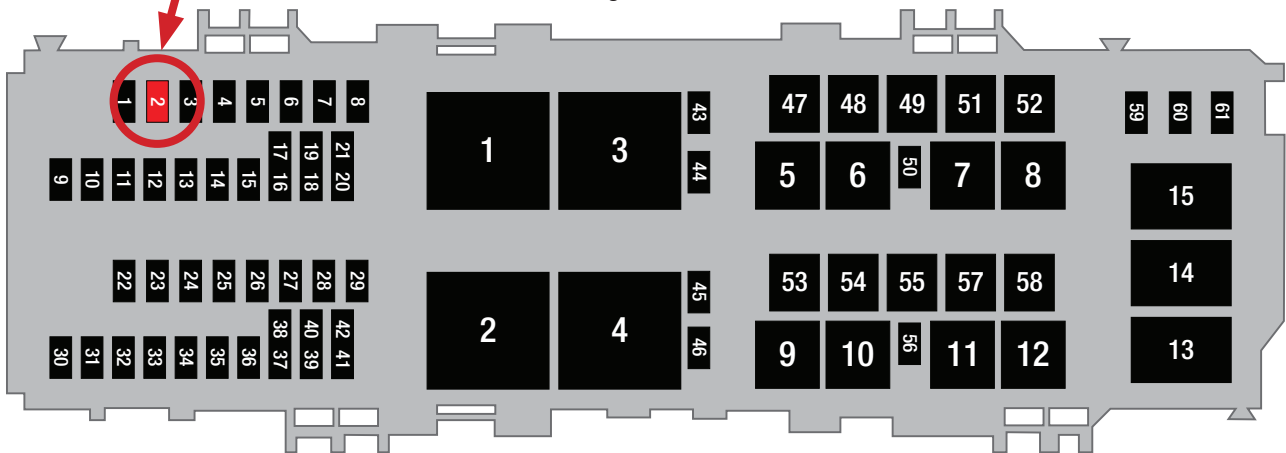

- Just behind the front storage compartment, install the Fuse Panel Mounting Bracket with the OEM bolt and 13mm socket making sure to place the provided spacer between the bracket and the vehicle.

ProMax fuse panel shown.



- Connect the fuse panel wiring per the diagram provided.

ProMax fuse panel shown.

IMPORTANT: All appropriate safety equipment (gloves, tools etc.) must be used during the installation of this product(s).

Nitro Dave's LLC accepts NO responsibility for injuries or damages resulting during and/or from the installation of any product(s). Nitrous oxide is for off-road use only.

WWW.NITROUSOUTLET.COM/INSTALLATION-GUIDES



2020-2021 C8 Corvette WinMax/ProMax Wiring Harness

PART NUMBER: 12-10119-WFR

PART NUMBER: 12-10119-PFR

INSTALLATION INSTRUCTIONS



- Using a 2" hole saw, drill a hole on the back of the front storage compartment, centered just above the sensor.



- Replace the front storage compartment in the front of the vehicle while directing the bottle accessory wiring through the 2" hole from the previous step.



- Plug in the bottle openers and heaters.



For ProMax:

- Plug in the fuel pressure sensor.

For WinMax:

- Remove the jumper wire on the terminal ends of the fuel pressure safety switch wires then plug in the fuel pressure safety switch.

****Note:** If you are not using a fuel pressure safety switch, leave the jumper wire connecting the terminals for the switch.

- If using a timing retard controller, connect the retard output to the controller.



IMPORTANT: All appropriate safety equipment (gloves, tools etc.) must be used during the installation of this product(s).

Nitro Dave's LLC accepts NO responsibility for injuries or damages resulting during and/or from the installation of any product(s). Nitrous oxide is for off-road use only.

WWW.NITROUSOUTLET.COM/INSTALLATION-GUIDES



2020-2021 C8 Corvette WinMax/ProMax Wiring Harness

PART NUMBER: 12-10119-WFR

PART NUMBER: 12-10119-PFR

INSTALLATION INSTRUCTIONS



- In the chassis tunnel, unplug the E4 connector on the ECU. This is the rear most connector.

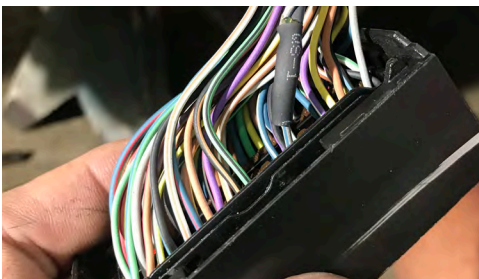

ProMax only:

- Pin into ECM per pinout diagram.

Tachometer – J4 connector – Pin 29 at ECM
TPS – J1 connector – Pin 39 at ECM
MAP – J4 connector – Pin 58 at ECM
Wideband – Requires aftermarket wideband controller

- Steps to use when working with ECM and Sensor connection points.

1. Locate the proper wire.
2. Isolate wires from harness
3. Cut wires
4. Slide heat shrink over wire
5. Soldier wires.
6. Slide heat shrink down and melt

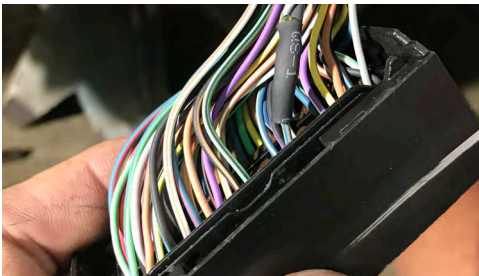

WinMax only:

- Pin into ECM per pinout diagram.

Tachometer – J4 connector – Pin 29 at ECM
TPS – J1 connector – Pin 39 at ECM

- Steps to use when working with ECM and Sensor connection points.

1. Locate the proper wire.
2. Isolate wires from harness
3. Cut wires
4. Slide heat shrink over wire
5. Soldier wires.
6. Slide heat shrink down and melt



- Using a 10mm socket, connect the wire between the fuse panel and the positive battery cable.



- Using a 10mm socket, connect the ground wire to the negative battery cable.

IMPORTANT: All appropriate safety equipment (gloves, tools etc.) must be used during the installation of this product(s).

Nitro Dave's LLC accepts NO responsibility for injuries or damages resulting during and/or from the installation of any product(s). Nitrous oxide is for off-road use only.

WWW.NITROUSOUTLET.COM/INSTALLATION-GUIDES



2020-2021 C8 Corvette WinMax/ProMax Wiring Harness

PART NUMBER: 12-10119-WFR

PART NUMBER: 12-10119-PFR

INSTALLATION INSTRUCTIONS



Step 4 – Final Check Over

- Reconnect the battery.



- Verify that tachometer, TPS and MAP function properly.



Step 5 – Final Assembly

- Under the car, reinstall the front panel.

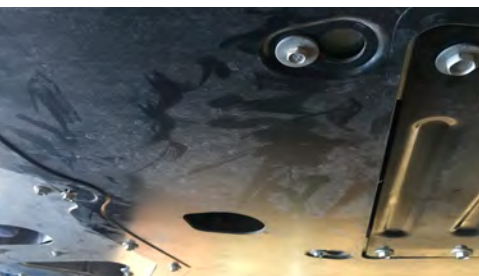

- Under the car, reinstall the rear panel.

IMPORTANT: All appropriate safety equipment (gloves, tools etc.) must be used during the installation of this product(s).

Nitro Dave's LLC accepts NO responsibility for injuries or damages resulting during and/or from the installation of any product(s). Nitrous oxide is for off-road use only.

WWW.NITROUSOUTLET.COM/INSTALLATION-GUIDES



2020-2021 C8 Corvette WinMax/ProMax Wiring Harness

PART NUMBER: 12-10119-WFR

PART NUMBER: 12-10119-PFR

INSTALLATION INSTRUCTIONS



- Under the car, reinstall the center panel.



- Under the car, reinstall both small metal panels.



- In the front storage compartment, reinstall the 2 net tabs.



- Reinstall the 4 mounting screws.



- Reconnect the front storage light/power port connector.

IMPORTANT: All appropriate safety equipment (gloves, tools etc.) must be used during the installation of this product(s).

Nitro Dave's LLC accepts NO responsibility for injuries or damages resulting during and/or from the installation of any product(s). Nitrous oxide is for off-road use only.

WWW.NITROUSOUTLET.COM/INSTALLATION-GUIDES



2020-2021 C8 Corvette WinMax/ProMax Wiring Harness

PART NUMBER: 12-10119-WFR

PART NUMBER: 12-10119-PFR

INSTALLATION INSTRUCTIONS



- Reinstall the 4 trim panels around the front storage compartment.



- Inside the vehicle, reinstall the fuse panel cover.



- Place the carpet over the fuse panel.



- Reinstall the rear console cover. Plug in the phone charger and speaker.



- Reinstall the speaker cover.

IMPORTANT: All appropriate safety equipment (gloves, tools etc.) must be used during the installation of this product(s).

Nitro Dave's LLC accepts NO responsibility for injuries or damages resulting during and/or from the installation of any product(s). Nitrous oxide is for off-road use only.

WWW.NITROUSOUTLET.COM/INSTALLATION-GUIDES



2020-2021 C8 Corvette WinMax/ProMax Wiring Harness

PART NUMBER: 12-10119-WFR

PART NUMBER: 12-10119-PFR

INSTALLATION INSTRUCTIONS



- Push the carpet back in place on the side of the center console then reinstall the side console panel.

IMPORTANT: All appropriate safety equipment (gloves, tools etc.) must be used during the installation of this product(s).

Nitro Dave's LLC accepts NO responsibility for injuries or damages resulting during and/or from the installation of any product(s). Nitrous oxide is for off-road use only.

WWW.NITROUSOUTLET.COM/INSTALLATION-GUIDES



Deutsch Connector Assembly Instructions

INSTALLATION INSTRUCTIONS

Deutsch Connector Assembly:

To assemble Deutsch terminal ends you can use a special crimper, or if done cautiously, this can be done with a pair of needle nose pliers.

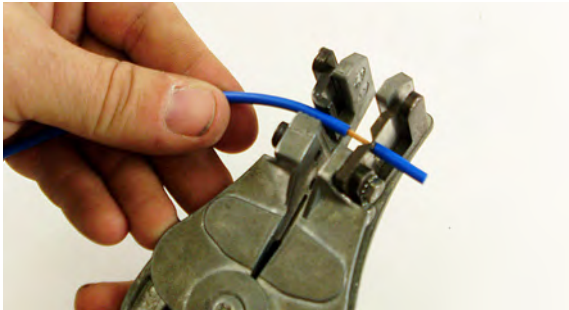

Step 1:

Strip the end of the wire you want to place the connector on about 3/8".



Step 2:

Using a crimp tool or needle nose pliers, crimp the connector down. First the smaller crimp and then the larger crimp, make sure the weather pack seal gets crimped with the larger side.



Step 3:

Once your sure you have a good crimp slide the pins into the connector housing being sure to match the wires correctly on each side. Push the pin in the housing until you feel a positive click and the wire cannot be pulled back out of the connector.



Step 4:

Install the provided pin retainer lock in the connector body. It simply snaps in to place.

IMPORTANT: All appropriate safety equipment (gloves, tools etc.) must be used during the installation of this product(s).

Nitro Dave's LLC accepts NO responsibility for injuries or damages resulting during and/or from the installation of any product(s). Nitrous oxide is for off-road use only.

WWW.NITROUSOUTLET.COM/INSTALLATION-GUIDES



PRO



WIRING HARNESS

12-10119-PFR – Nitrous Outlet 20-21 GM C8 LT2 Corvette Pro Wiring Harness – ProMax / Front Battery / Rear Dedicated

The ProMax Pro Wiring Harness is designed to be used in either AFR Mode or 2 stage mode. However, we do have a bonus feature!

AFR Mode:

Requires the addition of a wideband air/fuel controller to be used in conjunction with the ProMax Nitrous controller. The AFR mode controls the nitrous and fuel solenoid independent of one another to achieve the air fuel ratio programmed in the ProMax Nitrous Controller. This requires wiring the nitrous solenoid into the stage 1 side of the harness and the fuel solenoid into stage 2 of the harness.

2 Stage Mode:

Does not require the addition of a wideband air/fuel controller. The 2-stage mode allows you to use the harness in a single stage or dual stage configuration. This requires wiring the nitrous and fuel solenoid together per stage of the harness. For Example: If only using a single stage the nitrous and fuel solenoid would wire to stage one on the harness.

Bonus Feature:

Using the supplied AFR to 2 Stage Solenoid Y Adapter's you have the option of switching from AFR Mode to the 2-stage mode without having to change your solenoids wiring configuration. Just simply add in the Y adapters and change the program in the ProMax controller.

Table of Contents

AFR Mode and Dual Stage Wiring Diagram	2-4
Wiring Color and Gauge Identification Chart	5
Switch Panel Wiring and Identification Chart	5
Dual Bottle Upgrade Wiring and Components	6
Dual Bottle Upgrade Fuse Panel Addendum	6
ProMax and Sensor Connector Identification	7
Direct Port Addendum connector and connection	8
12V Switched Fuse and ECM Pin Identification	9
12-10119-PFR – Nitrous Outlet 2020 GM C8 LT2 Corvette Pro Wiring Harness – ProMax / Front Battery / Rear Dedicated Single Heater / Single Opener	10
12-10119-PFR – Nitrous Outlet 2020 GM C8 LT2 Corvette Pro Wiring Harness – ProMax / Front Battery / Rear Dedicated Dual Heater / Dual Opener	11
Pin Out Wiring Color/Gauge Location Chart	12

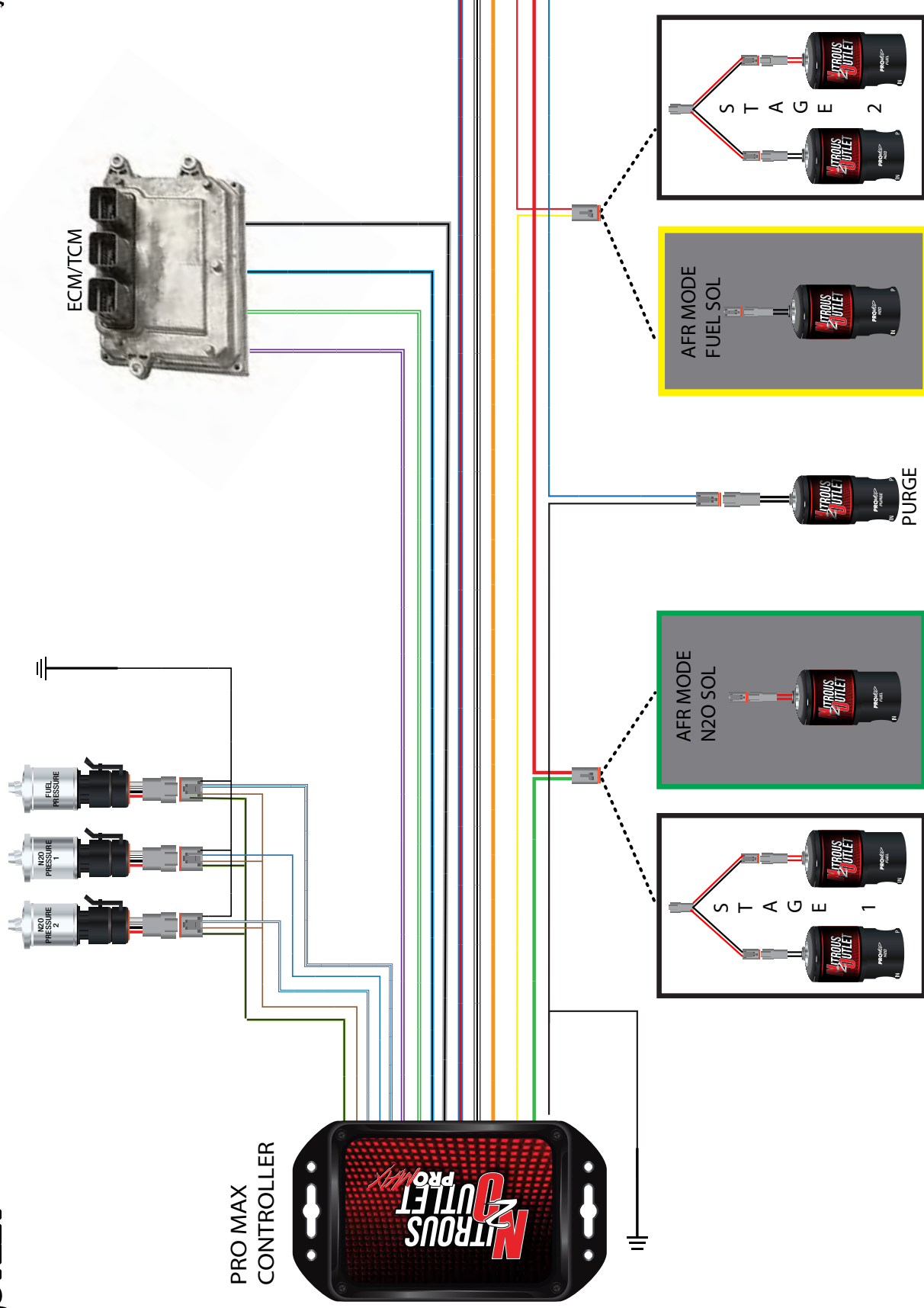

IMPORTANT All appropriate safety equipment (gloves, tools etc.) must be used during the installation of this product(s). Nitro Dave's LLC accepts NO responsibility for injuries resulting in the installation of any product(s). Nitrous oxide is for off-road use only.

WWW.NITROUSOUTLET.COM/INSTALLATION-GUIDES

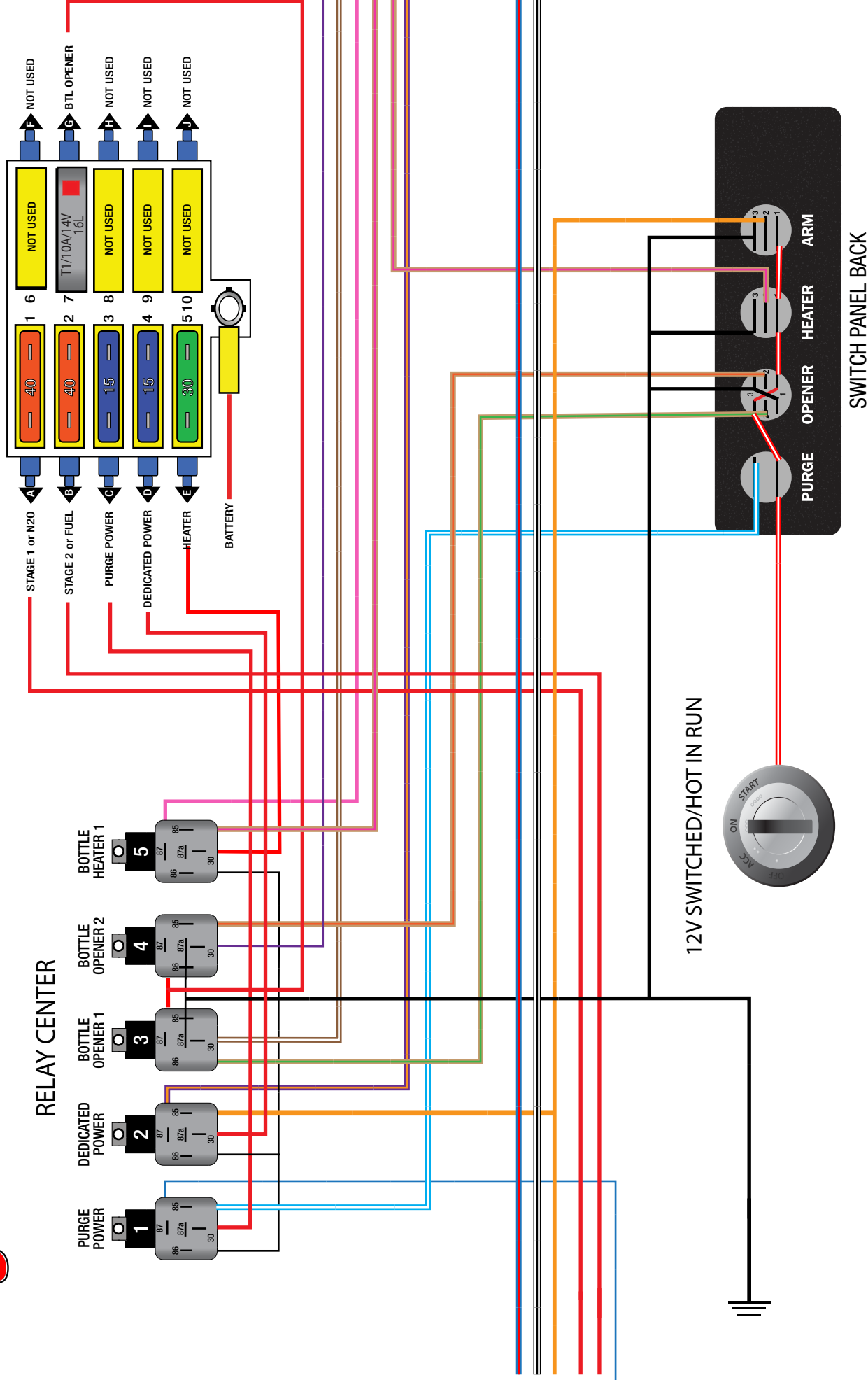

IMPORTANT All appropriate safety equipment (gloves, tools etc.) must be used during the installation of this product(s). Nitro Dave's LLC accepts NO responsibility for injuries resulting in the installation of any product(s). Nitrous oxide is for off-road use only.

12-10119-PFR ProMax Wiring Harness

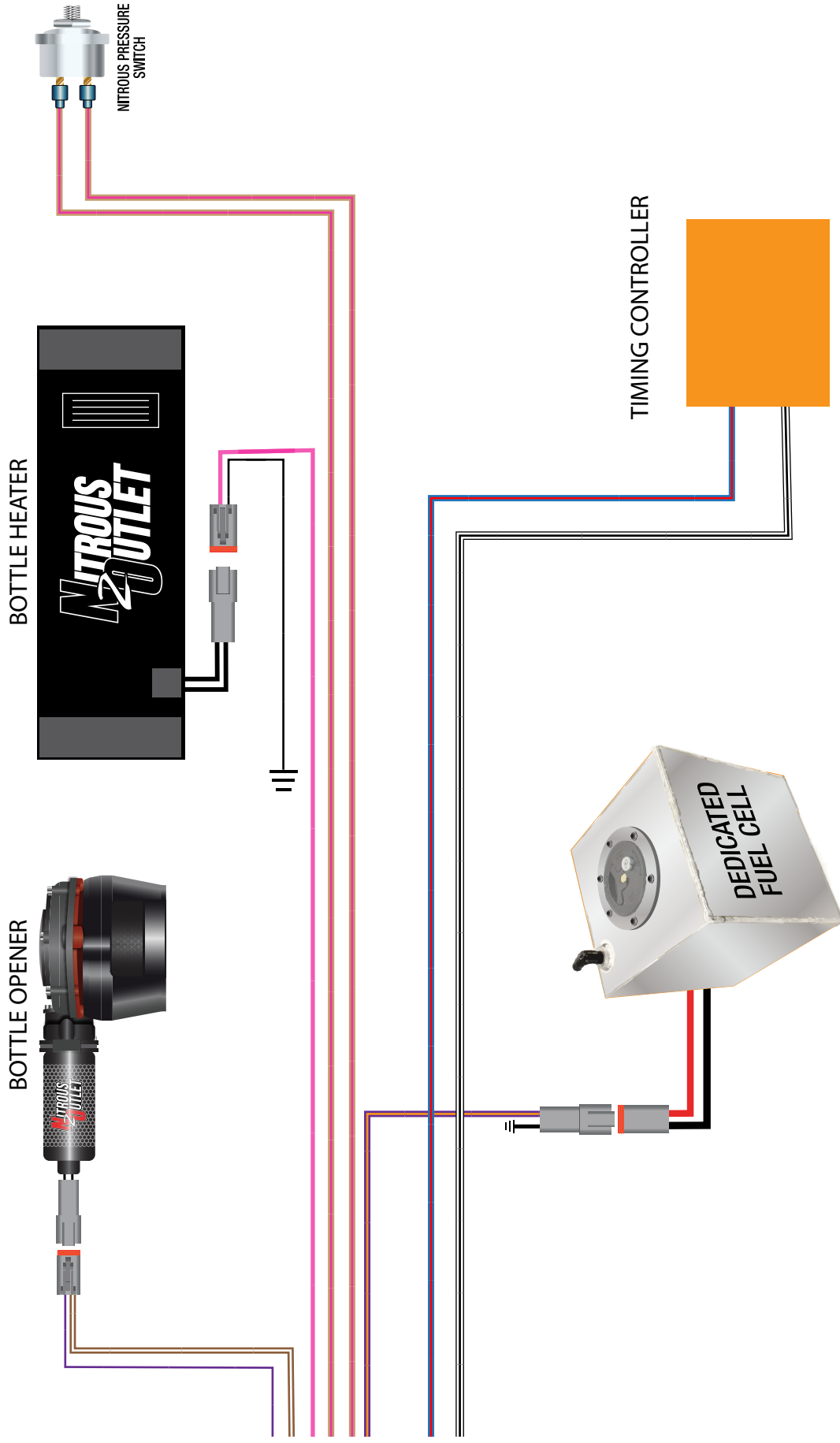

IMPORTANT All appropriate safety equipment (gloves, tools etc.) must be used during the installation of this product(s). Nitro Dave's LLC accepts NO responsibility for injuries resulting in the installation of any product(s). Nitrous oxide is for off-road use only.

WWW.NITROUSOUTLET.COM/INSTALLATION-GUIDES

FUSE PANEL

- #1 STAGE 1 or N2O - 10ga RED
- #2 STAGE 2 or FUEL - 10 ga RED
- #3 PURGE PWR - 12ga RED
- #4 DEDICATED PWR - 12ga RED
- #5 BTL HEATER - 10ga RED
- #7 REM OPENER - 10ga RED

- Cont OP Stg1 Solenoids/ Stg1 N2O Sol. - 10ga Green
- Cont OP Stg2 Solenoids/Stg1 Fuel Sol. - 10ga Yellow
- Controller Battery/Eng/Chassis Ground

PROMAX CONTROLLER

- 5V Sup / Sensors - 18ga Light Green/Black
- Sensor Grnd - 18ga Brown
- Input N2O Sensor 1 - 18ga Blue
- Input N2O Sensor 2 - 18ga Blue/White
- Input Fuel Sensor 18ga White/Blue
- TPS Input - 18ga Green/White
- VSS Input - 18ga Gray/Black
- Tach Input - 18ga Purple/White
- MAP Input 18ga - Light Blue/Black
- 12V Switched 16ga - Orange
- OP Stg1 Ign Ret - 18ga White/Black
- OP Stg2 Ign Ret - 18ga Blue/Red
- 12V Trns Brk Sig - 18ga Green
- N2O Press Sw - 16ga Tan/Pink

- Btl Htr Comp - 10ga Pink
- Btl Htr Comp - 10ga Black
- Btl Opnr - 12ga Purple
- Btl Opnr - 12ga Brown/White
- N2O SOL - 10GA RED
- N2O SOL - 10GA GREEN
- FUEL SOL - 10GA RED
- FUELSOL - 10GA YELLOW
- PURGE - 12GA BLUE
- PURGE - 12GA BLACK
- DED - 12GA PUR/ORG
- DED - 12GA BLACK
- STG1 IGN RET - 18GA BLUE/RED
- STG2 IGN RET - 18GA WHT/BLACK

SWITCH PANEL CONNECTION GUIDE

Nitrous Outlet 2020 GM C8 LT2 Corvette
Pro Wiring Harness
ProMax / Front Battery / Rear Dedicated

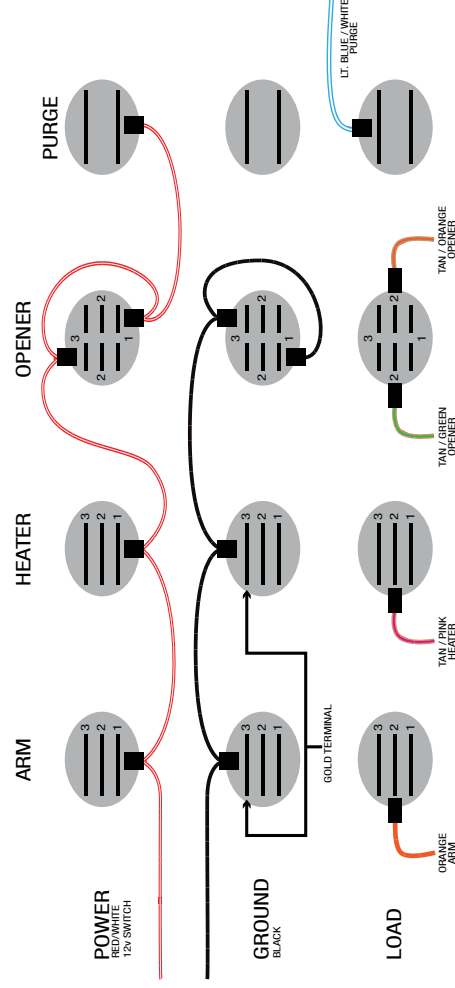

IMPORTANT All appropriate safety equipment (gloves, tools etc.) must be used during the installation of this product(s). Nitro Dave's LLC accepts NO responsibility for injuries resulting in the installation of any product(s). Nitrous oxide is for off-road use only.

WWW.NITROUSOUTLET.COM/INSTALLATION-GUIDES



DUAL HEATER / DUAL OPENER FUSE BLOCK DIAGRAM

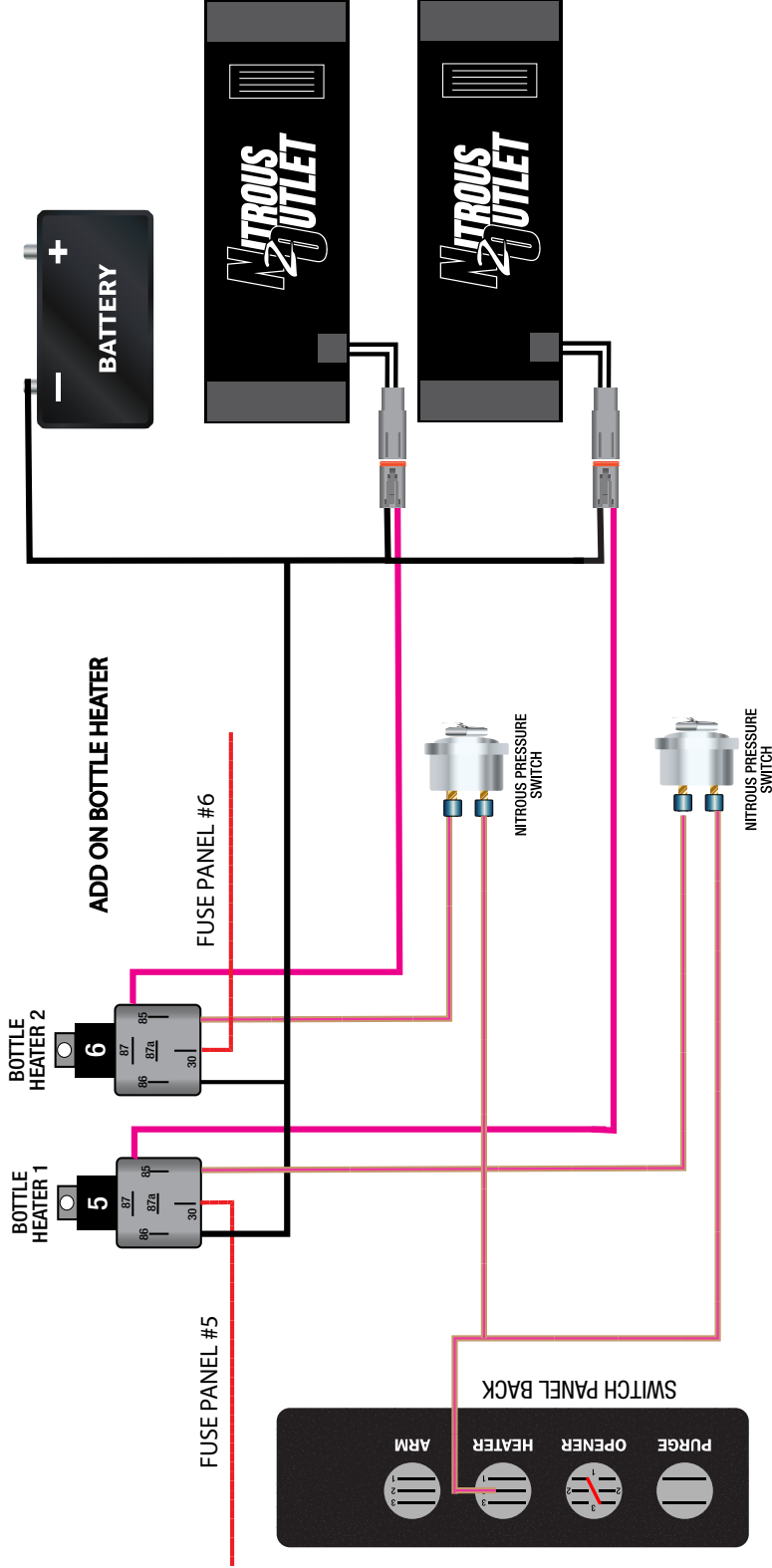
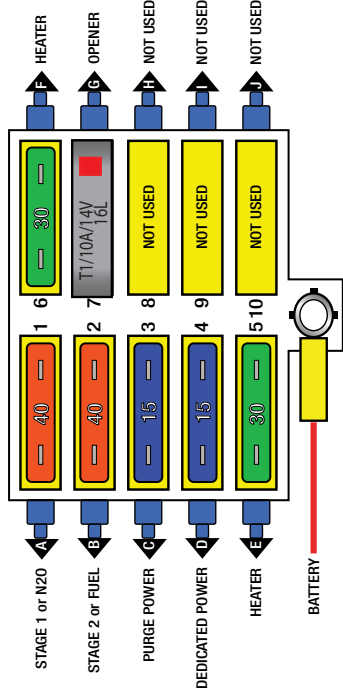

IMPORTANT All appropriate safety equipment (gloves, tools etc.) must be used during the installation of this product(s). Nitro Dave's LLC accepts NO responsibility for injuries resulting in the installation of any product(s). Nitrous oxide is for off-road use only.

SENSOR CONNECTORS

N2O SENSOR #1 CONNECTOR



N2O SENSOR #2 CONNECTOR



FUEL PRESSURE SENSOR #1 CONNECTOR

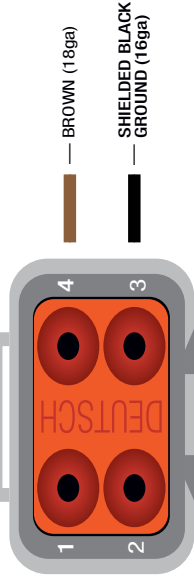

STAGE 1 & 2 TIMING RETARD CONNECTOR

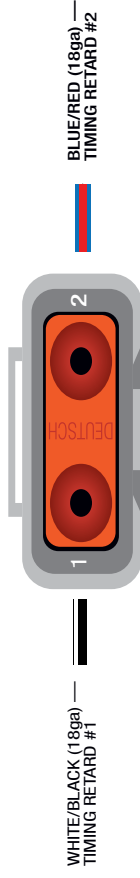

PROMAX CONTROLLER CONNECTORS

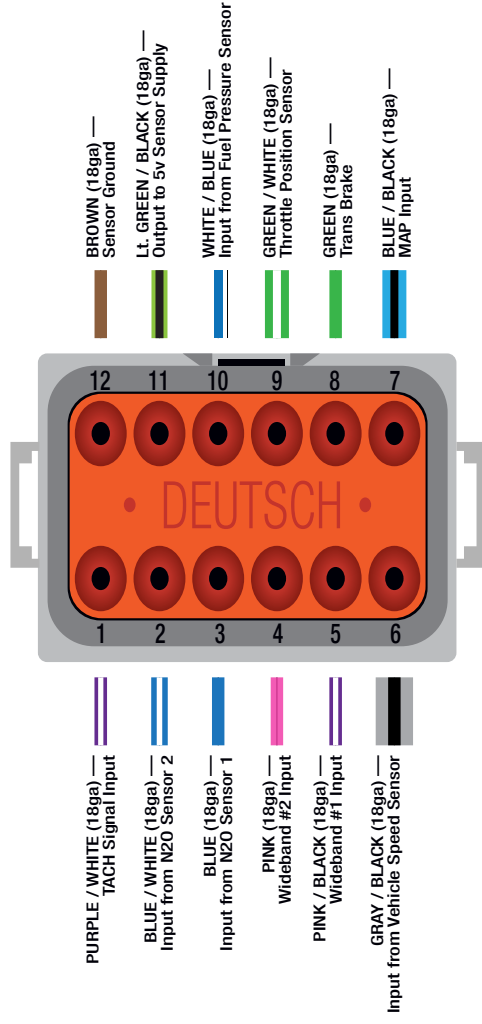
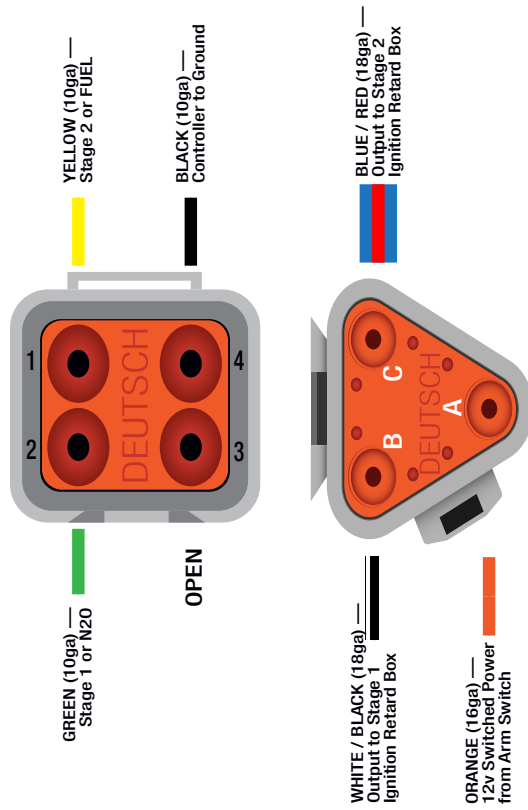

IMPORTANT All appropriate safety equipment (gloves, tools etc.) must be used during the installation of this product(s). Nitro Dave's LLC accepts NO responsibility for injuries resulting in the installation of any product(s). Nitrous oxide is for off-road use only.

WWW.NITROUSOUTLET.COM/INSTALLATION-GUIDES

DIRECT PORT ADDENDUM

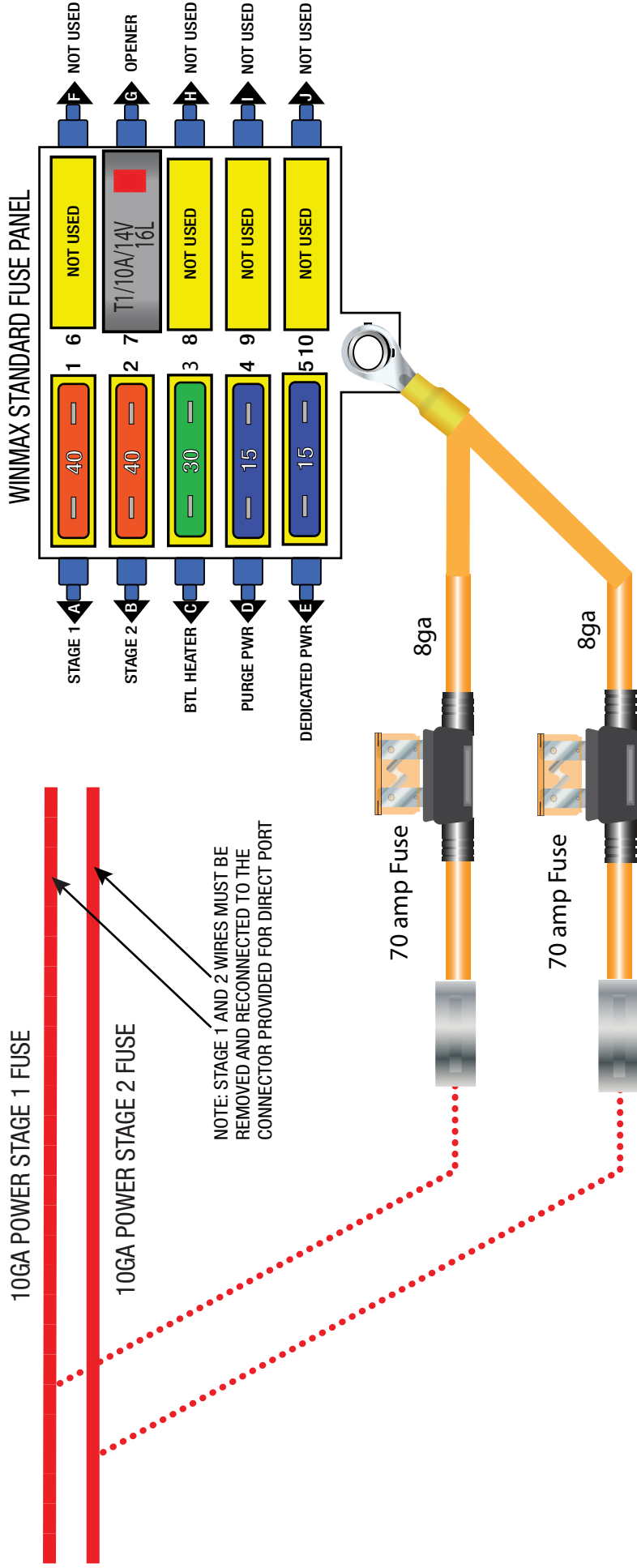

The Illustration shows the required modification needed to upgrade your WinMax Pro Wiring Harness to a 4 solenoid system such as Direct Port. (PER STAGE)

VEHICLE 12V SWITCHED AND SENSOR CONNECTIONS

CONFIGURATION TYPE: 2020 GM C8 LT2 CORVETTE

Nitrous Outlet 2020 GM C8 LT2 Corvette Pro Wiring Harness – ProMax / Front Battery / Rear

Fig. 1 12V Switched - Fuse 2 located at fuse panel, under console behind driver and passenger seat.

Fig. 2 TPS - Connector J1 pin 39 at ECM

Fig. 3 TACH Connector J4 pin 29 at ECM

Fig. 3 MAP - Connector J4 pin 58 at ECM -

Set to: 0.5V- 93 KPA/13.5 PSI, 4.5V- 17.2 KPA/2.5 PSI

NOTE: Vehicle Speed - 2020 and newer corvette vehicles will need to install an aftermarket stand alone speed sensor as the ProMax will not read the factory speed sensors.

Wide Band - Requires Aftermarket Wide Band

MAIN FUSE PANEL BEHIND CENTER CONSOLE



● FUSE 2 - 12V SWITCHED

Fig. 1

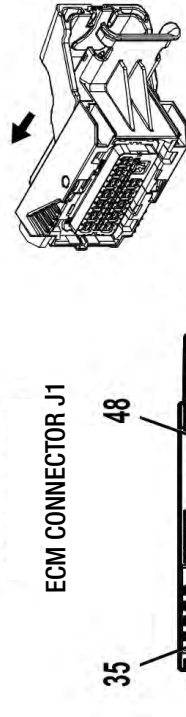

Fig. 2

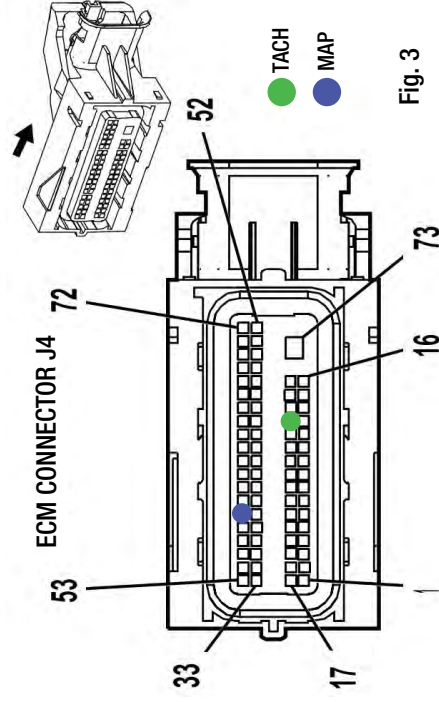

Fig. 3

IMPORTANT All appropriate safety equipment (gloves, tools etc.) must be used during the installation of this product(s). Nitro Dave's LLC accepts NO responsibility for injuries resulting in the installation of any product(s). Nitrous oxide is for off-road use only.

WWW.NITROUSOUTLET.COM/INSTALLATION-GUIDES

WIRING HARNESS AND COMPONENT PLACEMENT

CONFIGURATION TYPE: 2020 GM C8 LT2 CORVETTE

Nitrous Outlet 2020 GM C8 LT2 Corvette Pro Wiring Harness – ProMax / Front Battery / Rear

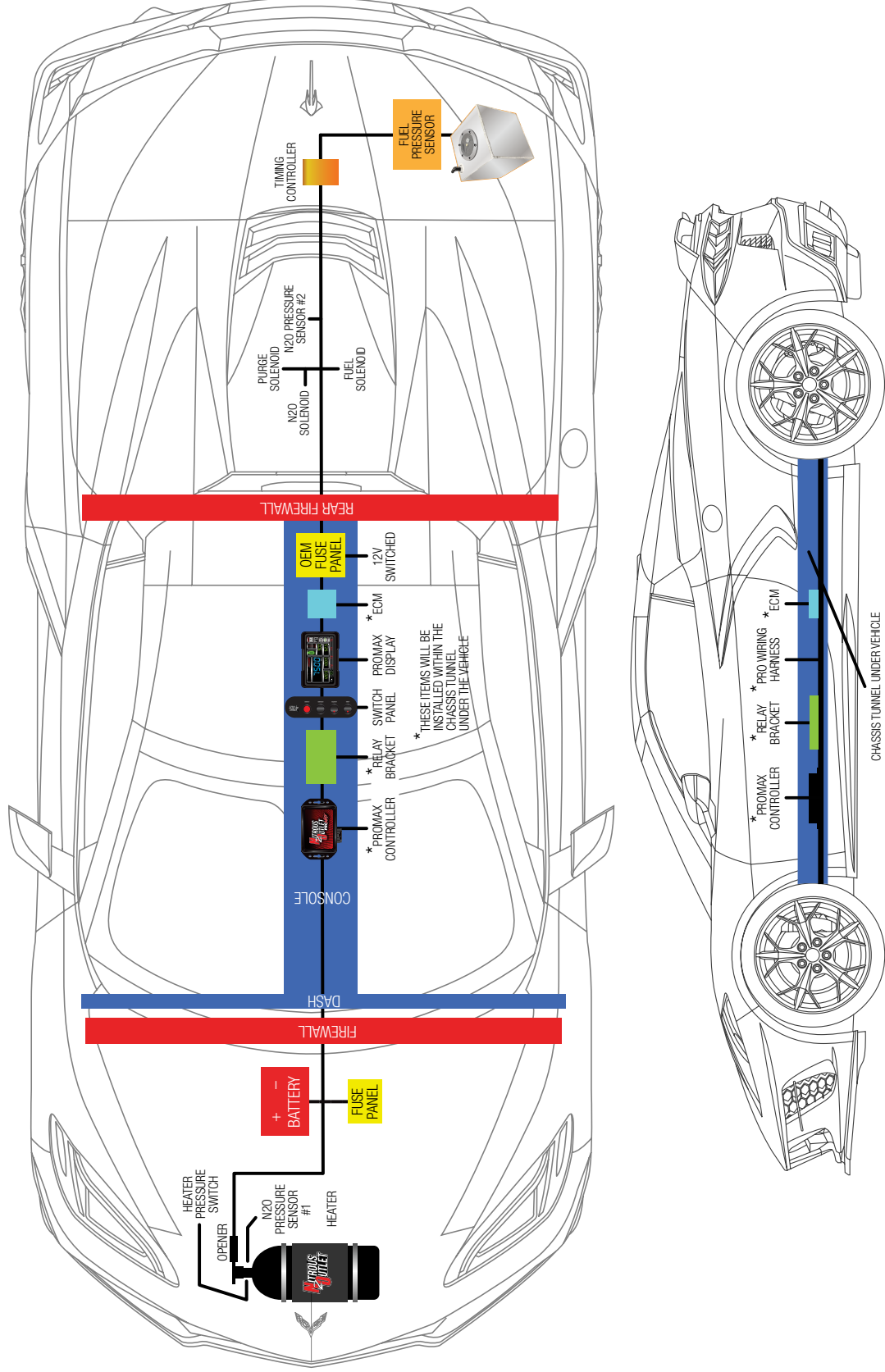

IMPORTANT All appropriate safety equipment (gloves, tools etc.) must be used during the installation of this product(s). Nitro Dave's LLC accepts NO responsibility for injuries resulting in the installation of any product(s). Nitrous oxide is for off-road use only.

WWW.NITROUSOUTLET.COM/INSTALLATION-GUIDES

WIRING HARNESS AND COMPONENT PLACEMENT

CONFIGURATION TYPE: 2020 GM C8 LT2 CORVETTE

Nitrous Outlet 2020 GM C8 LT2 Corvette Pro Wiring Harness – ProMax / Front Battery / Rear

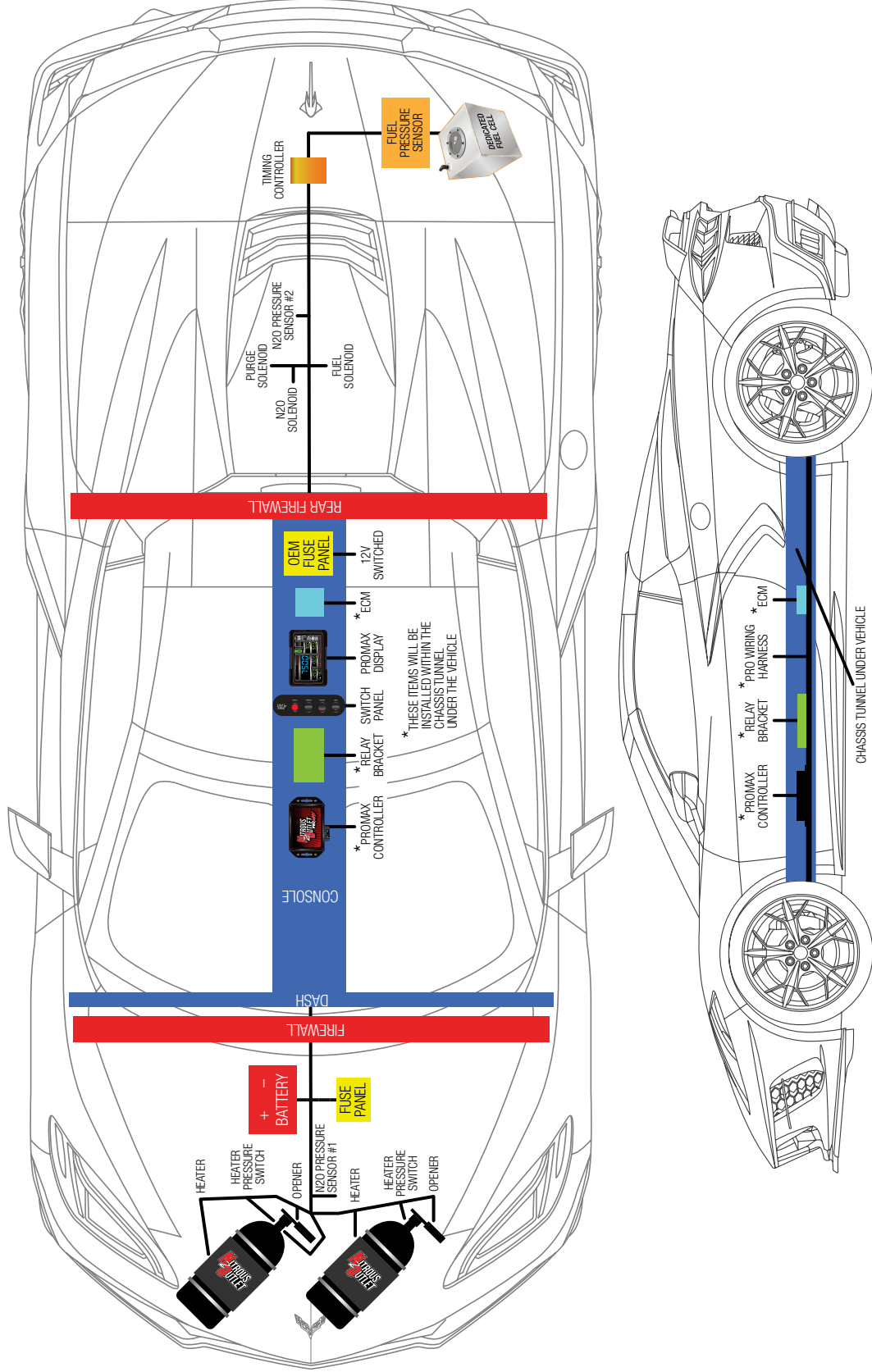

IMPORTANT All appropriate safety equipment (gloves, tools etc.) must be used during the installation of this product(s). Nitro Dave's LLC accepts NO responsibility for injuries resulting in the installation of any product(s). Nitrous oxide is for off-road use only.

WWW.NITROUSOUTLET.COM/INSTALLATION-GUIDES

PROMAX WIRING DIAGRAM PIN OUT SHEET

PROMAX CONTROLLER	
GREEN	10GA GROUND TRIGGER FROM CONT.
YELLOW	10GA GROUND TRIGGER FROM CONT.
BLACK	10GA GROUND TO BATT.
ORANGE	16GA 12V FROM ARM SWITCH
LT GREEN/BLACK	18GA 5V FOR SENSORS
BROWN	18GA SENSOR GROUND
BLUE	18GA INPT-N20 SENSOR 1
BLUE/WHITE	18GA INPT-N20 SENSOR 2
WHITE/BLUE	18GA INPT-FPS SENSOR
PURPLE/WHITE	18GA INPT-TACH SIGNAL
GREEN/WHITE	18GA INPT-TPS SIGNAL
LT BLUE/BLK	18GA INPT-MAP SIGNAL
GREY/BLACK	18GA INPT-VSS SIGNAL
GREEN	18GA 12V SIGNAL-TRANS BRAKE
WHITE/BLACK	18GA OUTPT STAGE 1 TIMING
BLUE/RED	18GA OUTPT STAGE 2 TIMING
RED/WHT	16GA 12V SWITCHED FROM FUSE PANEL
SWITCH PANEL	
RED/WHITE	16GA 12V SWITCHED FROM FUSE PANEL
BLACK	16GA GROUND SPLICE FOR SW PANEL
ORANGE	16GA ARM SW- DED RELAY PIN 86
LTBLUE/WHITE	18GA PRG BTN- PURGE RELAY PIN 86
TAN/PINK	16GA HTR SW-HEATER RELAY PIN 86
TAN/ORANGE	18GA BTL OPNR SW-OPNR RELAY1 PIN 86
TAN/GREEN	18GA BTL OPNR SW-OPNR RELAY2 PIN 86
FUEL PRESSURE SENSOR	
LT GREEN/BLACK	18GA 5V SUPPLY TO SENSORS
BROWN	18GA SENSOR GROUND FROM PROMAX
WHITE/BLUE	18GA INPUT FUEL PRESSURE SENSOR
BLACK	16GA SHIELDED GROUND TO BATTERY
N20 PRESSURE SENSOR 1&2	
LTGREEN/BLACK	18GA 5V SUPPLY VOLTAGE TO SENSORS
BROWN	18GA GROUND FOR SENSOR(S)FROM PROMAX
BLUE	18GA INPUT N20 SENSOR 1
BLUE/WHITE	18GA INPUT N20 SENSOR 2
BLACK	16GA SHIELDED GROUND TO BATTERY -

RELAY CENTER	
RELAY#1 PURGE	
RED	10GA FUSE 3 - PIN 30 PURGE RELAY
BLACK	16GA BATTERY GROUND - PIN 86
BLUE	12GA PURGE SOLENOID - PIN 87 PURGE RELAY
LT.BLUE/WHITE	18GA PURGE BUTTON-PIN 85 PURGE RELAY
RELAY#2 DEDICATED	
RED	12GA FUSE 4- PIN 30 DEDICATED RELAY
BLACK	16GA BATTERY GROUND - PIN 86
PURPLE/ORANGE	12GA DEDICATED- PIN 87 ON DED RELAY
ORANGE	16GA ARM SWITCH-PIN 85 DED RELAY
RELAY # 3 BOTTLE HEATER	
RED	10GA FUSE 5 - PIN 30 HEATER RELAY
BLACK	16GA BATTERY GROUND - PIN 86
PINK	10GA BOTTLE HEATER - PIN 87 HEATER RELAY
TAN/PINK	16GA HEATER SWITCH - PIN 85 HEATER RELAY
RELAY#4 BOTTLE OPENER	
RED	12GA JUMPER TO RELAY#5 PIN 30 - FUSE 7
BLACK	16GA JUMPER -RELAY#5 - BATTERY GROUND
BROWN/WHITE	12GA BOTTLE OPENER - PIN30 OPNR RELAY
TAN/ORANGE	18GA BTL OPNR SWITCH - PIN 85 OPNR RELAY
RELAY#5 BOTTLE OPENER	
RED	10GA PIN 30 - FUSE 7
BLACK	16GA PIN 87A, 85 TO BATTERY GROUND
PURPLE	12GA BOTTLE OPENER - PIN 30 BTL OPNR RELAY
TAN/GREEN	18GA BTL OPNR SW - PIN 86 OPNR RELAY
PURGE SOLENOID	
BLUE	12GA PURGE SOL - PIN 87 PURGE RELAY
BLACK	12GA BATTERY GROUND
BOTTLE HEATER	
PINK	10GA BOTTLE HEATER - PIN 87 HEATER RELAY
BLACK	10GA BATTERY GROUND
BOTTLE OPENER	
PURPLE	12GA BOTTLE OPENER - PIN30 RELAY#4
BROWN/WHITE	12GA BOTTLE OPENER - PIN30 RELAY#5
DEDICATED	
PURPLE/ORANGE	12GA DEDICATED - PIN 87 DEDICATED RELAY
BLACK	12GA BATTERY GROUND

IMPORTANT All appropriate safety equipment (gloves, tools etc.) must be used during the installation of this product(s). Nitro Dave's LLC accepts NO responsibility for injuries resulting in the installation of any product(s). Nitrous oxide is for off-road use only.

WWW.NITROUSOUTLET.COM/INSTALLATION-GUIDES