



**Electro-Hydraulic**

**UTV Lift Bench**

**U-2200-IEH**

**Capacity 2,200lbs**

**Installation, Operation & Maintenance  
Manual**



Apr. 2016

# CONTENT

## **1. Safety Information**

- 1.1 Note, Caution and Warning
- 1.2 Important Information
- 1.3 Safety Instructions

## **2. Technical Specifications**

- 2.1 Product Description
- 2.2 Technical Data
- 2.3 Hydraulic Schematic
- 2.4 Circuit Diagram

## **3. Preparing and Installation**

- 3.1 Site Selection
- 3.2 Surface Condition
- 3.3 Necessary Tools
- 3.4 Personal Protective Equipment
- 3.5 Set-Up & Installation
- 3.6 Starting Up (No Load)

## **4. Operation**

- 4.1 Caution and Warning Label
- 4.2 Operation Instructions

## **5. Maintenance Instructions**

## **6. Exploded Views & Parts List**

## **7. Trouble Shooting Guide**

# 1. Safety Information

## 1.1 Note, Caution and Warning

This document uses the following conventions—**Note, Caution and Warning** – to alert you to special instructions, tips, or hazards for a given procedure. Please familiarize yourself with the conventions described below.

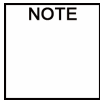

Indicates important information that requires special attention, such as a procedure for a specific vehicle, or tips on operating the equipment.



Indicates the potential for damage to equipment, accessories, or the vehicle unless you follow the instructions or procedure exactly.



Indicates the potential for property damage, personal injury, or death due to hazards associated with the equipment, vehicle, or environment. Do not perform any procedure until you have read and understood the warning instructions.

## 1.2 Important Information

1. Carefully read this manual thoroughly before installing, operating, or maintaining this lift.
2. This lift is designed for indoor use only, and should not be installed in a pit or depression.
3. The lifts have specific electrical requirements as described in the Installation Instructions section of this manual.
4. Failure by the owner to provide the **recommended shelter, mounting surface, electrical supply, and ceiling height** could result in unsatisfactory lift performance, property damage, or personal injury.
5. The operation of the lift is permitted by authorized person only.
6. Keep this guide as well as all the supplied technical literature in a safe place close to the lift so that operators are able to read it whenever necessary.
7. If any confusion, please contact the service provider or your distributor.

## 1.3 Safety Instructions

1. **Do not** raise a vehicle on the lift until the initialization is completed as described in this manual.
2. Technicians should be trained to use and care for the lift by familiarizing themselves with the publications listed above. The lift should **never be operated by an untrained person.**

3. **Do not overload the lift.** The capacity of the lift is shown on cover of this document and on the lift's serial number tag.
4. Positioning the vehicle is very important. Only trained technicians should position the vehicle on the lift. **Never allow anyone to stand in the path of the vehicle as it is being positioned and never raise vehicle with passengers on vehicles.**
5. Keep everyone clear of the lift when the lift is moving, the locking mechanism is disengaged, or the vehicle is in danger of falling.
6. Unauthorized personnel should never be in the shop area when the lift is in use.
7. Inspect the lift daily. **The lift should never be operated if it has damaged components, or is malfunctioning.** Only qualified technicians should service the lift. **Replace damaged components with manufacturer's parts, or equivalent.**
8. **Keep the area around the lift clear of obstacles.**
9. **Never override the self-returning lift controls.**
10. Avoid excessive rocking of the vehicle when it is on the lift.
11. To reduce the risk of personal injury, keep hair, loose clothing, fingers, and all body parts away from moving parts.
12. To reduce the risk of electric shock, **do not** use the lift when wet, do not expose the lift to rain.
13. To reduce the risk of fire, **do not** operate equipment in the vicinity of open containers of flammable liquids (gasoline).
14. Use the lift only as described in this manual, **use only manufacturer's recommended attachments.**
15. The maintenance procedures described in this manual can be done by the lift's owner/employer. Any other procedure should only be performed by trained lift service personnel. **These restricted procedures include, but are not limited to, the following: cylinder replacement, platform& safety latch replacement, motor replacement, oil replacement& refilling and lubrication.**
16. Anyone who will be in the vicinity of the lift when it is in use should familiarize themselves with following Caution, Warning, and Safety related decals supplied with this lift, and replace them if they are illegible or missing.
17. Never move the lift when the vehicle is loaded.

- 18. Only use on a level concrete surface with a recommended minimum thickness of 4". DO NOT install on an asphalt surface.
- 19. Only remove the vehicle when the lift platform is at the lowest position.
- 20. Never lift the vehicle with person's riding on it.



**IMPORTANT INSTRUCTIONS**

- The operation of the lift is permitted by authorised persons only.
- The lift is used for indoor only and should be placed on the flat ground.
- It shall draw attention to the rule that the load carrying device shall be observed by the operator throughout the motion of the lift.
- It is forbidden for people to stand in the field of motion of the load and the load carrying device during the movement, if appropriate.
- It is forbidden to climb onto the load or load carrying device when they are raised unless via a specifically designed access.

**IMPORTANT INSTRUCTIONS**

- Movable and mobile lifts shall be prevented from moving unintentionally.
- It is necessary to refer to the complete operation instructions, especially for trouble shooting.
- The field of motion of the load and of the load carrying devices shall be free of obstructions.
- It shall draw attention to the safe method of carrying the load and to the rule that, after raising a short distance, the vehicle shall be checked to ensure that it is correctly and safely positioned.

## 2. Technical Specification

### 2.1 Product Description

The U-2200-IEHUTV lift bench is used for repairing and maintaining Side by Side Utility type Vehicles by 110VAC-60Hz, 1Ph power source incorporating the latest safety technologies. The U-2200-IEH is designed and manufactured for a lifting capacity of 2,200 lbs. (1,000kg), and is fully capable for lifting UTV Side by Side Vehicles, safely holding them in an elevated position, locked position.

The electro-hydraulic UTV lift consists of a fixed structural scissor lift and a hand held remote controller.

### 2.2 Technical Specifications

Capacity:	2,200 lbs.(1,000 kg)
Lifting Height, Max:	47.2" (1,200 mm)
Height, Min:	7" (180 mm)
Width Overall:	65" (1651mm)
Length Overall:	121" (3072 mm)
Platform Length:	88.6" (2,250 mm)
Platform Width:	65" (1651 mm)
Power Supply:	110V, 60Hz, 1 Phase,18A
Lifting Time:	30 S
Lowering Time:	30 S
Noise Level:	<70db
Net Weight:	869lbs.
Gross Weight:	970lbs.

# U-2200-IEH Dimension Drawings

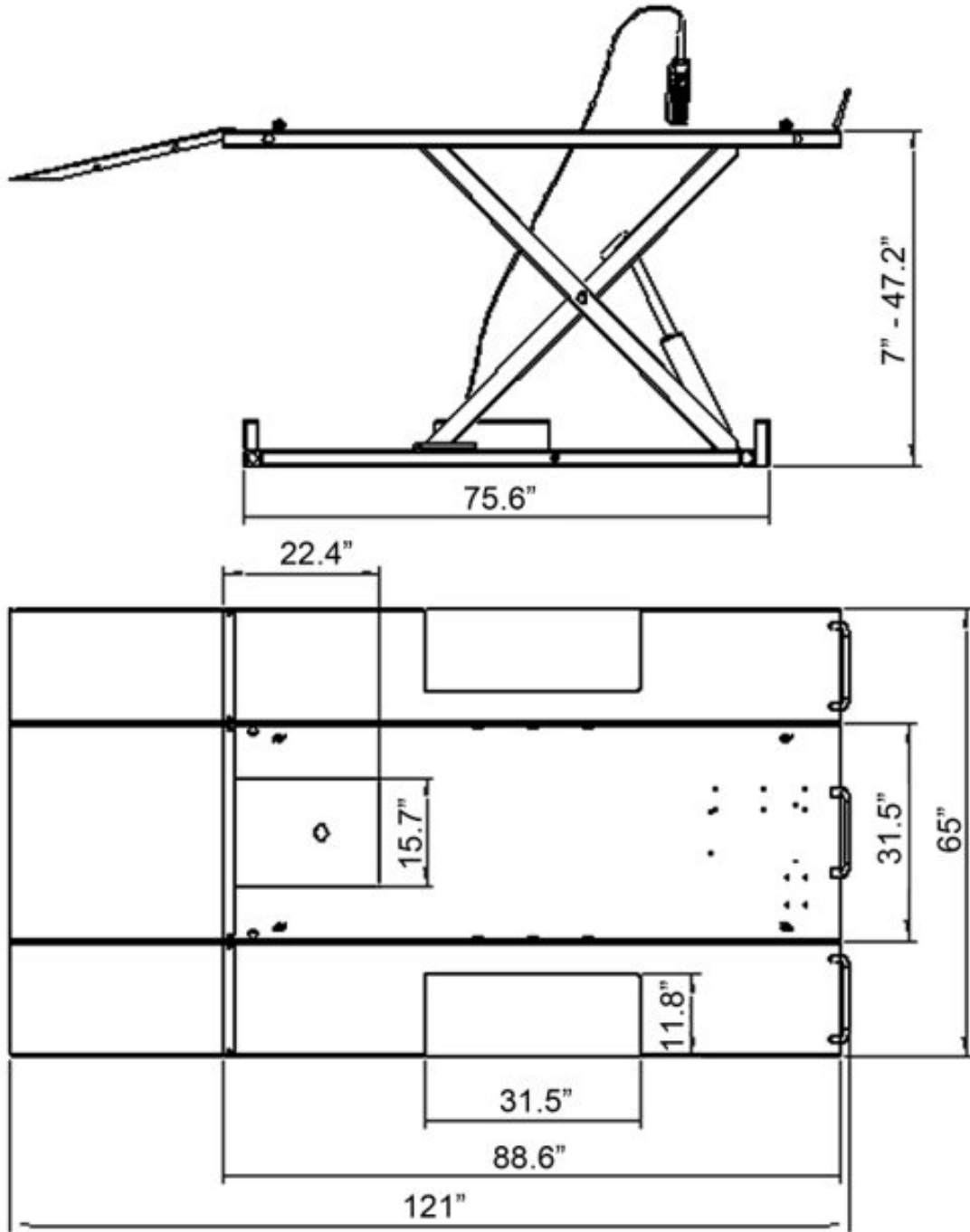

### 2.3 Hydraulic Schematic

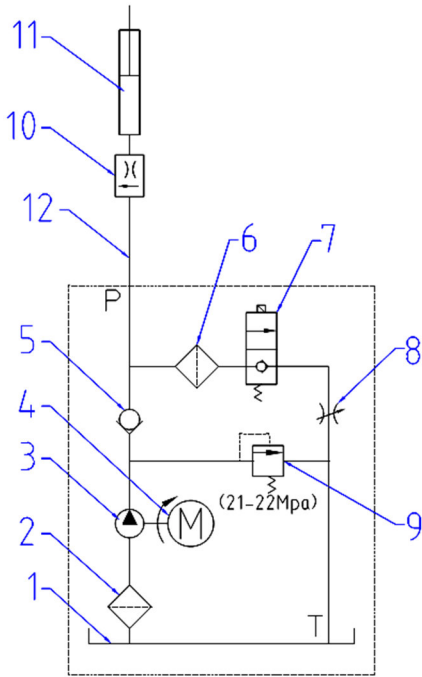

1. OIL TANK	2. MESH
3. GEAR PUMP	4. MOTOR
5. ONE-WAY VALVE	6. MESH
7. SOLENOID VALVE	8. RESTRICTOR VALVE
9. RELIEF VALVE	10. RESTRICTOR VALVE
11. CYLINDER	12. PIPE

### 2.4 Circuit Diagram

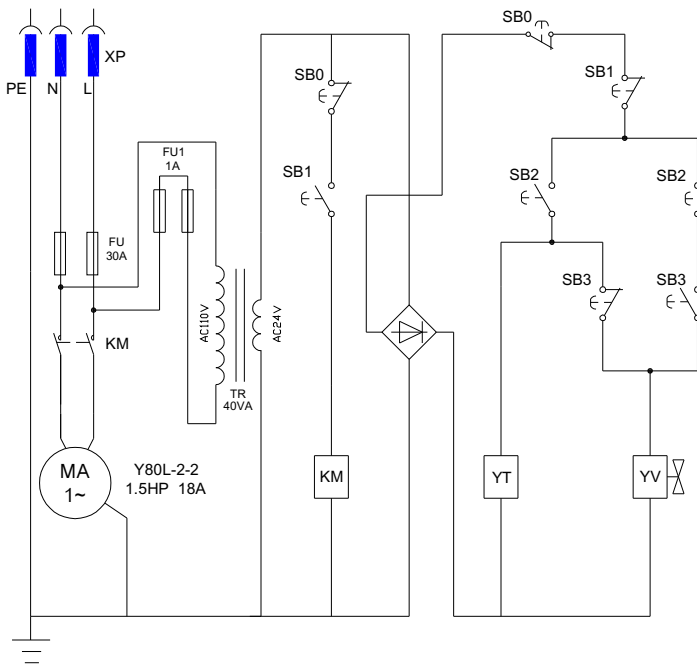

SB1	Switch	LA42P, 220V, 10A	1
SB2	Switch	LA42P, 220V, 10A	1
SB3	Switch	LA42P, 220V, 10A	1
SB0	Switch	LA42MY, 220V, 10A	1
KM	AC Contactor	NC1-09/10-24VAC	1
TR	Transformer	1PH, AC110V/AC24V, 40VA	1
FU	Fuses	φ6×30 delay, 30A	2
FU1	Fuses	φ5×20 delay, 1A	2
MA	AC Motor	ML802-4F, 1PH/110V/60Hz, 1.5HP	1
YV	Electromagnet	TAU1564T, 24VDC, 520mA	2
YT	Solenoid Valve	24VDC, 1A	1



### 3. Preparing and Installation

#### 3.1. Site Selection

The hydraulic UTV lift is designed only for indoor use. Application in a room with explosion hazard is not permitted. Setting in a wet place, a car wash bay for instance, is also not recommended. Make sure to check the desired location for possible obstructions such as a low ceiling, overhead lines, adequate working area, access ways, exits, etc.

#### 3.2. Surface Condition

The lift should be installed on level ground with a concrete surface free from as many defects as possible to prevent unit from tipping or rocking. Only use on a level concrete surface with a recommended minimum thickness of 4". DO NOT install on an asphalt type surface.



**Failure in accomplish the foundation requirement may cause the lift instability or personal injury. Installing on asphalt, soft clay floor or near the expansion gap is prohibited.**

#### 3.3. Necessary Tools

Rubber Hammer, Sockets and Open End Spanner. Ratchet Driver, Vice Grips

#### 3.4. Personal Protective Equipment

Always wear proper protective Equipment like proper clothing, shoes, gloves & glasses, etc.

#### 3.5. Set-Up & Installation

##### 1. Unpacking

Open the carton. Using a forklift to take out the lift then move to desired position (Fig.1). Check product and packing list to make certain all required parts are in good condition.



Fig.1

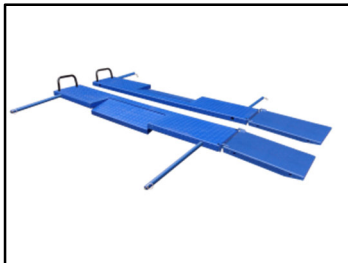

Fig. 2



Fig 3

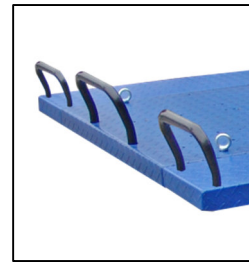

Fig. 4

## 2. Assembling

- a. Insert rod completely through the hole on UTV side extension panel.(Fig 2)
- b. Tighten the rod with bolt.
- c. Insert the securing pin on each end of rod.
- d. Put on the ramp at the end of the platform.
- e. Connect the ramps with nut and bolt.
- f. Insert the stabilizer/ balance bar. (Fig 3)
- g. Insert the wheel stop into the holes on the platform. (Fig 4)
- h. Screw the eyebolt into the corners of platform. (Fig 4)

## 3. Change the Tank Plug

Remove 'black' shipping Plug from reservoir tank and install only the 'brass' ventilating Plug on reservoir tank. (Fig. 5)

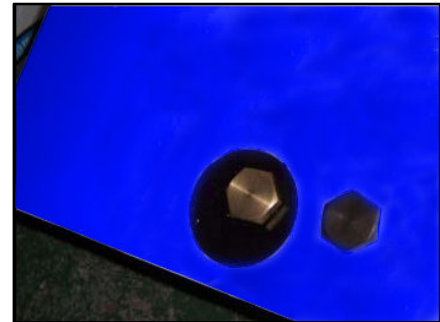

Fig. 5

## 4. Power Connection

Before power connection is made, check your power supply outlet to ensure it's in accordance with the requirements of the lift.

Connect lift's electrical plug to an 110V-60Hz, 1Ph, 20A power supply outlet. Protection against power surges shall be provided by the user.

### 3.6. Starting Up (No Load on Lift)

1. Using the Remote Pendant Control, raise the platform to full height by pressing the **UP ↑** button. (Fig 6)
2. Lower the lift to floor by press **DOWN ↓** button.
3. With no load on lift, cycle up and down for several times to get air out of the hydraulic system. (Wait 2 minutes between cycles)
4. Ensure to check that all hardware and components are properly secured & installed correctly.

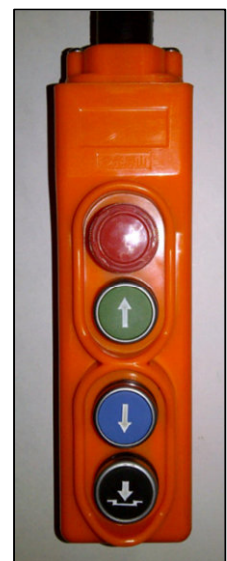

Fig.6

**The Lift is now ready for Operation.**

## 4. Operation

Be sure to read and familiarize yourself with the Safety Instructions at the beginning of this manual. Be sure to wear gloves, protection glasses and all necessary personal protective equipment. Failure to follow Safety Instructions may result in property damage, personal injury or death.

### 4.1 Caution and Warning Label



### 4.2 Operating Instructions



Be sure to read and familiarize yourself with the Safety Instructions at the beginning of this manual. Failure to follow Safety Instructions may result in property damage or personal injury.



To avoid personal injury and/or property damage, permit only trained personnel to operate lift.



**DO NOT** leave ramp(s) attached to lift while in operation or in up position.



**ALWAYS** use tie downs to secure vehicle to lift while in operation.

#### 4.2.1 Lift Preparation:

Lift must be fully lowered and area clear of all personnel before vehicles are placed on lift.

#### 4.2.2 Loading Lift:

Carefully push the vehicle on the fully lowered lift platform while keeping the vehicle centered and aligning the center of gravity of the equipment with the center of the lift platform. (For motorcycles, push forward until the front wheel touches the Wheel Stop or engages into the 'optional' mounted Vise or Chock).



**Securing UTV.** Engage the parking brake on the vehicle, if applicable. Secure UTV to lift using tie-down straps. Straps are recommended to be used to properly secure UTV to lift platform.

**4.2.3 Power Connection**

Connect Lift's electrical Plug in to power outlet (110VAC, 20 amp) once the lift is properly located.





**Before attempting to lift any vehicles, be sure that vehicle is stable and properly secured on lift**

**4.2.4 Emergency Button**

The lift can be switched off by pressing down the emergency button on Remote Pendant Control.

**4.2.5 To Raise Lift & Lock**

- a. Push UP button (  ) on the remote 'hand held' pendant controller.
- b. Raise vehicle to the desired height, then release the UP button.
- c. Push the PARKING button (  ) to lower the vehicle onto the locking position, the locking latch will automatically engage.



**When any emergency situation comes, press down the emergency stop button immediately to stop the lift. When emergencies are solved, 'twist & pull' the red knob to release the emergency button to disengage the emergency stop.**

**4.2.6 To Lower Lift**

- a. Check all danger points of the lift and be sure that there are no objects or people in the working area (danger area) around the lift or under the lift.
- b. If the platform is already in the locked position (latches are engaged), press UP button to raise the lift a short distance to disengage the latch mechanism.
- c. Then press DOWN button (  ) on remote controller to lower lift.
- d. Observe the complete lowering process for any unexpected movement.
- e. Carefully remove the vehicle off of the lift platform after the lift is at the lowest position.



**Center Drop Panel usage: If side extension's Center Drop Panels are lowered (folded down), ensure to securely latch back into level position with platform, prior to lowering lift. Failure to do so, could result in lift, vehicle & property damage.**



**Remain clear of lift when lowering vehicle. Observe pinch point warning decals.**

**If lift is not operating properly, DO NOT use until adjustment or repairs are made by qualified lift service personnel.**



**DO NOT use the PARKING button instead of the DOWN button to lower.**



**NEVER press UP or DOWN button for a long time while the lift is not moving, or the control system will be damaged. Release button if you find the lift is not properly responding to the button actuated.**



**Once finished operation, engage the emergency button and unplug the lift.**



**If any unsafe movement of the lift happens, do not to operate the lift anymore and call the local distributor for assistance.**

## 5. Maintenance Instructions

Contact your service provider for instructions before starting up if you are not completely familiar with lift's maintenance procedures. Only qualified personnel can perform maintenance on this equipment. Any failure in operation may cause personal injury and/or damage to lift.

- ✓ Wear necessary protective equipment before use, includes, but not limited, gloves and protection glasses, working suits and shoes.
- ✓ Always keep bolts tight. Check periodically.
- ✓ Always keep lift components clean.
- ✓ If oil leakage is observed, contact your service provider.
- ✓ Check safety latches for free movement and full engagement with lift are properly working
- ✓ Check hoses connections for leakage.

### Every Month

- ✓ Lubricate locking latch shafts. Push latch handle several times for oil to penetrate joints.
- ✓ Lubricate the sliding pieces with heavy duty bearing grease.
- ✓ With lift lowered check the hydraulic fluid level. If necessary add oil as described in the Installation Instruction section of this manual
- ✓ Check platform latch synching: Latches should click at the same time.
- ✓ Check tightness of all bolts.
- ✓ Check the nuts for tightness every week for the first month, and every month afterwards.

### Every 6 Months

- ✓ Check and clean the oil filter, if applies.
- ✓ Check the hydraulic oil for proper level with lift in down position. Refill reservoir tank with hydraulic oil if necessary with AW 32 or AW46 Non-Detergent Non-Foaming Anti-Wear Hydraulic Oil.
- ✓ If Lift stops short of full rise or chatters, contact your service provider.
- ✓ Replace all caution, warning or safety related decals on the lift if unable to read or missing. Reorder labels from service provider.
- ✓ Check all components for wear.

## 6. Exploded Views & Parts List – (Lift Structure)

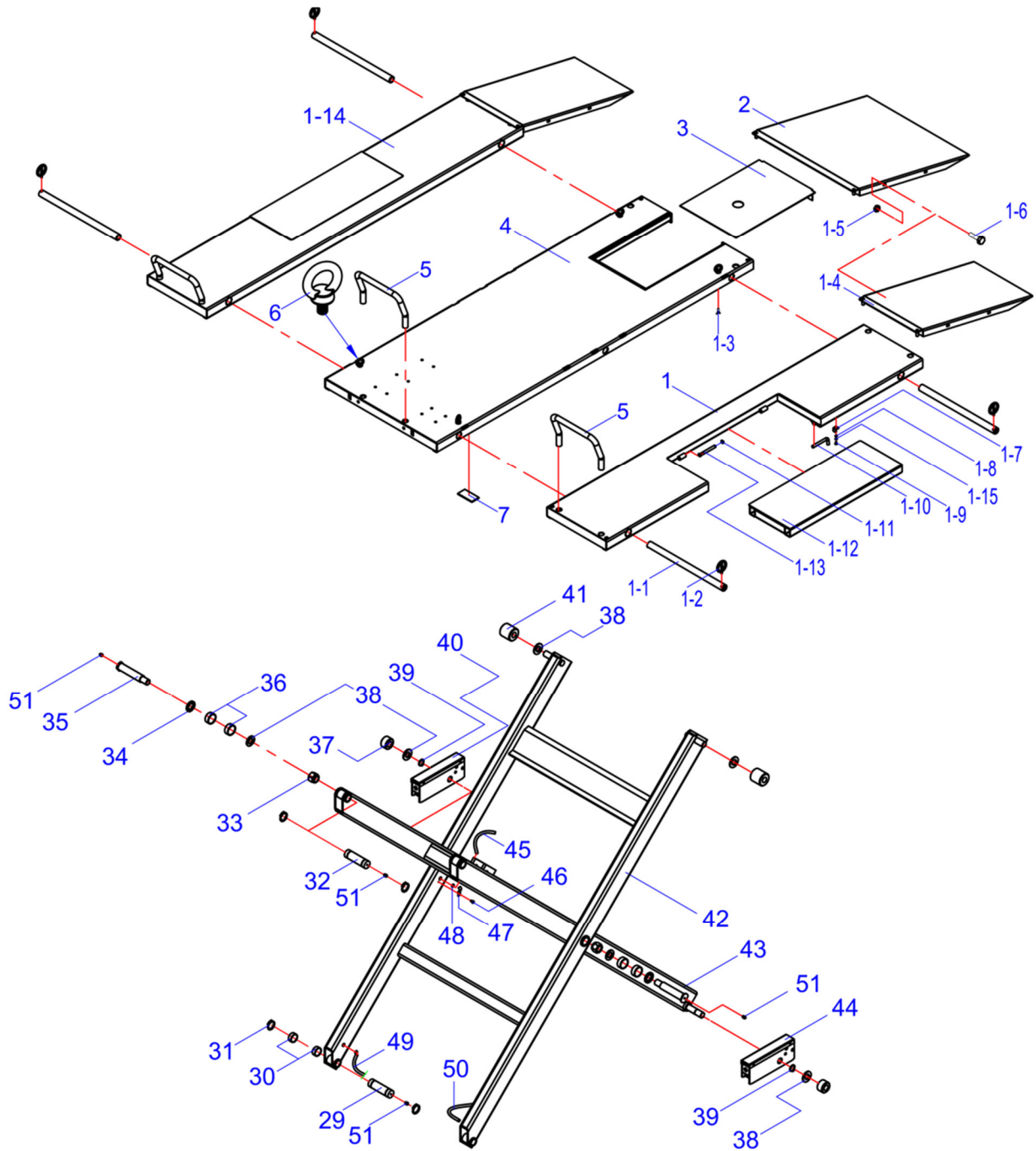

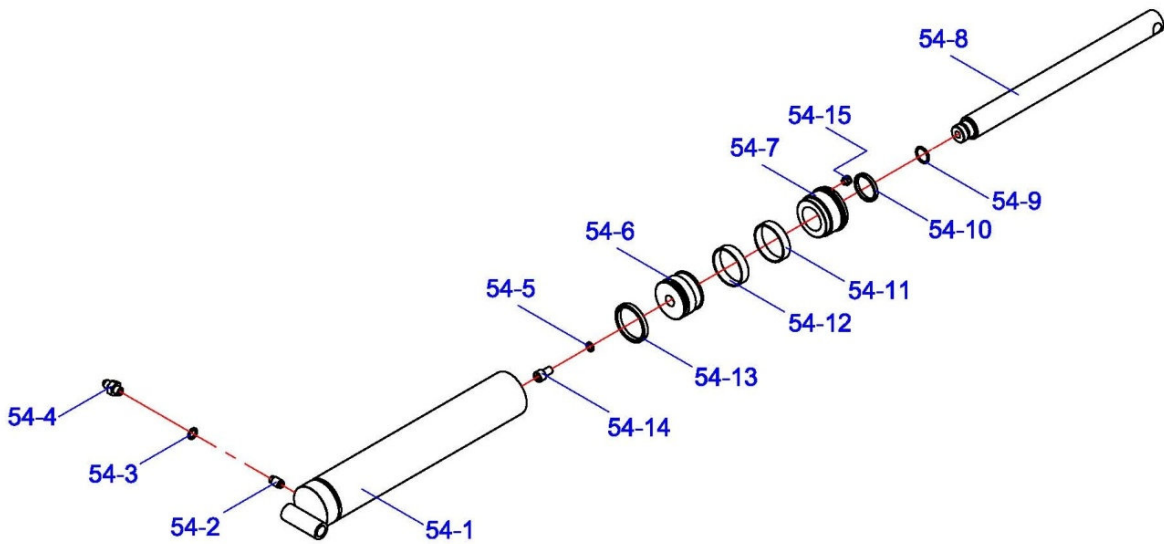
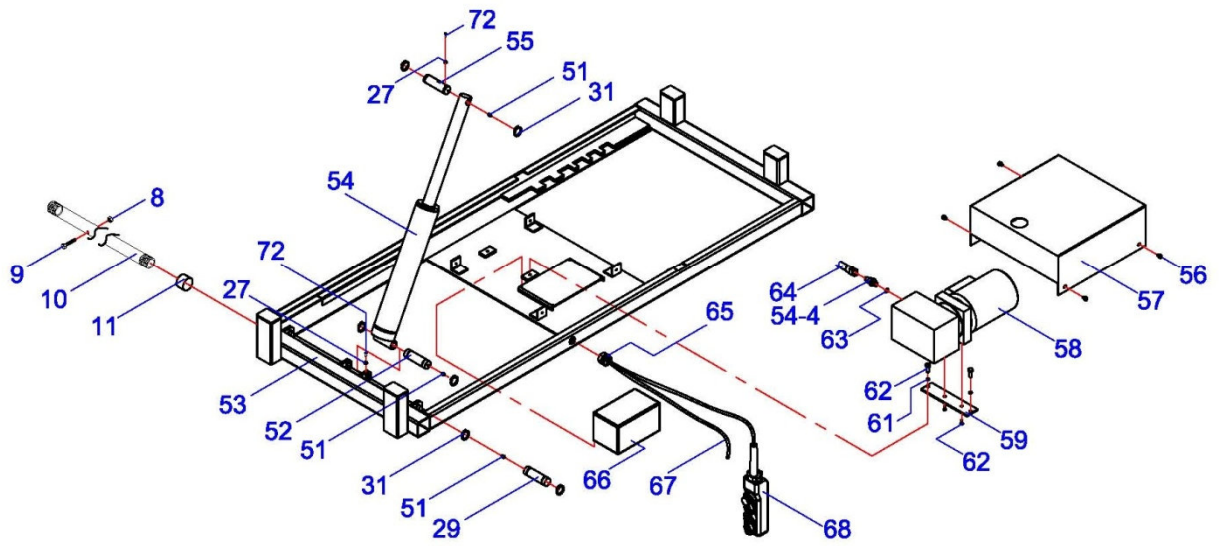



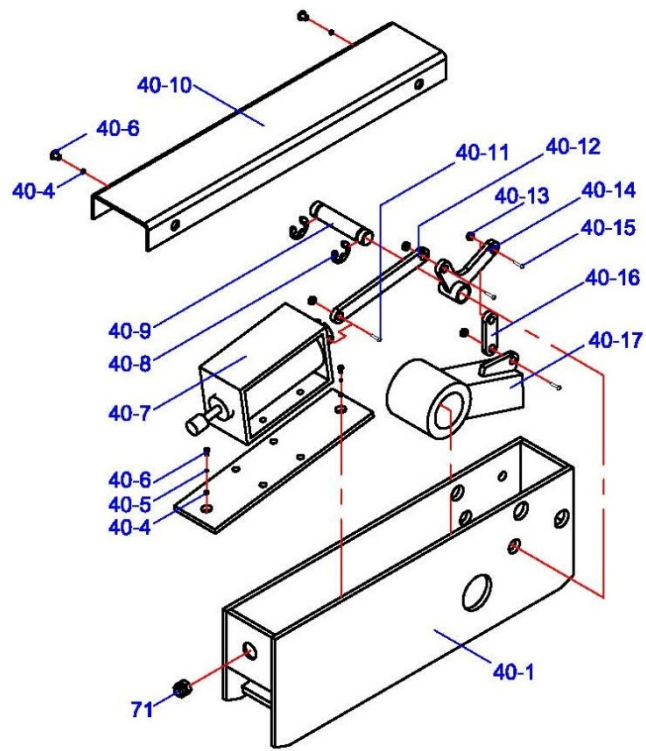

4

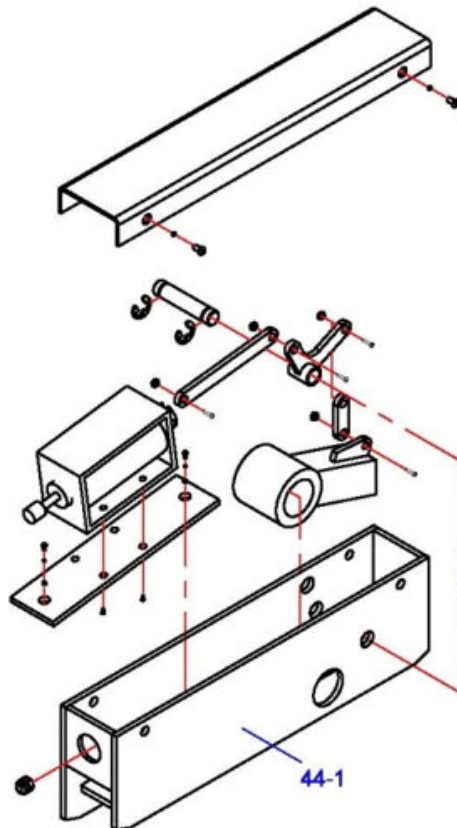

## Parts List - (Lift Structure)

ITEM	P/N	DESCRIPTION	QTY
1	JP23-05100-PB1	UTV side extension panel - LH	2
1-1	JP23-02001-PB2	rod	4
1-2	JP04-00005-000	securing pin	4
1-3	5121-10016-000	bolt	8
1-4	JP23-02200-PB2	ramp	2
1-5	5202-00008-000	hex nut	4
1-6	5103-08025-000	hex bolt	4
1-7	JP23-04002-PB4	baffle	4
1-8	5303-00006-000	spring washer	4
1-9	5110-06012-000	screw	4
1-10	JP23-04001-PB4	pin	4
1-11	5304-00012-000	circlip	8
1-12	JP23-04200-PB4	drop panel	2
1-13	JP24-00025-000	spindle	4
1-14	JP23-04100-PB4	UTV side extension panel - RH	1
1-15	5301-00006-000	flat washer	4
2	JP24-00014-000	ramp	1
3	JP23-08000-000	rear plate	1
4	JP23-01000-000	platform	1
5	JP17-00011-000	wheel stop	3
6	JP02-00009-000	eye-bolt	4
7	JP23-01012-000	rubber pad	4
8	5202-00006-000	hex nut	2
9	5103-06050-000	hex bolt	2
10	JP23-00001-000	stabilizer / balance bar	1
11	JP17-00010-000	Sleeve	2
27	5206-00005-000	lock nut	2
29	JP24-00001-000	shaft 1#	2
30	5603-20025-000	bearing	8
31	5304-00020-000	circlip	12
32	JP24-00002-000	shaft 2#	2
33	5206-00020-000	lock nut	2
34	5302-00025-000	flat washer	2
35	JP24-00003-000	bolt	2
36	5603-25025-000	bearing	8
37	JP24-00005-000	down roller	2
38	5302-00020-000	flat washer	6
39	5304-00025-000	circlip	2
40	JP24-14000-000	safety latch-left	1
40-1	JP24-14100-000	latch frame-left	1

40-4	5302-00005-000	flat washer	8
40-5	5303-00005-000	spring washer	4
40-6	5110-05012-000	screw	8
40-7	MK01-00300-000	electro-magnet	2
40-8	5305-00006-000	C-clips	4
40-9	JP24-13003-000	pin	3
40-10	JP24-00016-000	safety mechanism cover	2
40-11	5110-04020-000	screw	2
40-12	JP24-13001-000	long bar	2
40-13	5206-00004-000	lock nut	8
40-14	JP24-13200-000	rocker arm	2
40-15	5110-04012-000	screw	6
40-16	JP24-13002-000	short bar	2
40-17	JP24-13300-000	latch	2
41	JP24-00004-000	upper roller	2
42	JP24-03000-000	outer scissor frame	1
43	JP24-02000-000	inner scissor frame	1
44	JP24-13000-000	safety-latch-right	1
44-1	JP24-13100-000	safety-latch frame-right	1
45	JP24-00010-000	spring hose 1#	4
46	5110-04006-000	screw	10
47	JP24-00009-000	plate	10
48	MK01-00003-000	cable ring	8
49	JP24-00012-000	spring hose 3#	1
50	JP24-00011-000	spring hose 2#	1
51	JP02-00007-000	grease fitting	8
52	JP24-00024-000	cylinder long pin	1
53	JP24-05000-000	base	1
54	JP23-04000-000	hydraulic cylinder	1
54-1	JP23-04100-000	cylinder body	1
54-2	BZ20-04026-000	pressure valve	1
54-3	5903-00014-000	combined seal	1
54-4	JP24-04006-000	oil connector	2
54-5	5303-00012-000	spring washer	1
54-6	JP23-04002-000	piston	1
54-7	JP23-04004-000	guide ring	1
54-8	JP24-04007-000	piston rod	1
54-9	5901-00244-000	O-ring	1
54-10	5906-00040-000	dust ring	1
54-11	JP24-04008-000	guide belt	1
54-12	JP23-04001-000	guide belt	1
54-13	5905-00070-000	seal ring	1
54-14	5105-12020-000	screw	1
54-15	JP24-04009-000	muffler	1
55	JP24-00023-000	cylinder short pin	1

56	5117-06008-000	lock nut	4
57	JP24-00006-000	cover	1
58	DBZ14B-00	motor pump	1
59	JP24-00026-000	pump board	1
61	5303-00008-000	spring washer	2
62	5103-08014-000	hex bolt	4
63	5901-00118-000	O-ring	1
64	JP24-00007-000	hose	1
65	DJ02-00009-000	cable nut	1
66	MK01BS-00	remote control case	1
67	MK01-00002-000	cable	1
68	MK01-00200-000	remote pendant control	1
71	JP24-00027-000	cable clamp	2
72	5109-05014-000	screw	2

### Exploded View & Parts List – (Hydraulic Power Unit & Control Box)

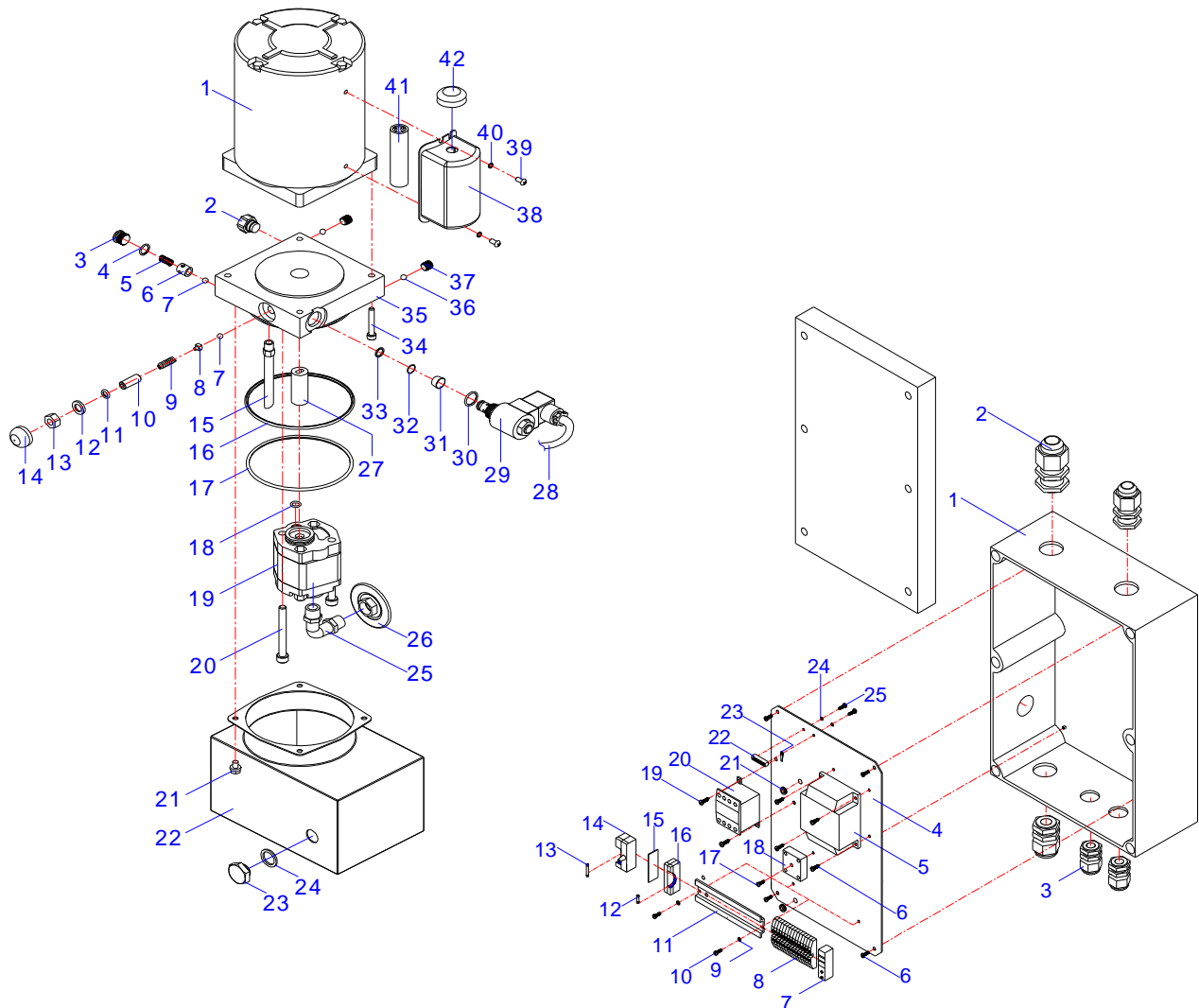

## Parts List – (Hydraulic Power Unit)

ITEM	P/N	DESCRIPTION	QTY
1	BZ14-05001-B00	single phase motor	1
2	BZ01-04010-000	close nut	1
3	BZ01-04008-000	close nut	1
4	5901-00118-000	O-ring	2
5	BZ01-04009-000	spring	1
6	BZ01-04007-000	ball seat	1
7	5601-00635-000	ball	2
8	BZ01-04005-000	ball seat	1
9	BZ01-04002-000	spring	1
10	BZ01-04003-000	threaded pin	1
11	5901-00072-000	O-ring	1
12	BZ01-04016-000	special washer	1
13	BZ01-04004-000	lock nut	1
14	BZ01-04-12-000	protect cap	1
15	BZ14-00001-000	return pipe	1
16	5901-01150-000	O-ring	1
17	5901-01120-000	O-ring	1
18	5901-00008-000	O-ring	1
19	BZ13-03000-B00	gear pump	1
20	5105-08075-000	bolt	2
21	5117-06008-000	self-lock nut	4
22	BZ14-02100-000	tank	1
23	QY02-03001-001	ventilating cover	1
24	QY02-03002-000	combined seal washer	1
25	BZ14-01001-000	sucking pipe	1
26	BZ01-01002-000	strainer	1
27	BZ14-00003-000	joint	1
28	BZ14-04200-000	valve cable	1
29	BZ20-04100-000	electromagnetic valve	1
30	5901-00160-000	O-ring	1
31	BZ01-04011-000	strainer	1
32	5901-00095-000	O-ring	1
33	5901-00125-000	Circlip	1
34	5105-06040-000	screw	4
35	BZ30-04001-000	valve block	1
36	5601-00800-000	ball	2
37	BZ01-00002-000	threaded pin	2
38	BZ14-05003-000	capacitor caver	1
39	5110-04010-000	screw	2
40	5302-00004-000	flat washer	2
41	BZ14-05002-B00	start capacitor	1
42	BZ14-05004-000	cable nut	1

## Parts List – (Control Box)

ITEM	P/N	DESCRIPTION	QTY
1	MK01-00001-000	case	1
2	JK01-00004-000	cable nut	2
3	DJ02-00007-000	cable nut	3
4	MK01-00101-000	bottom board	1
5	MK01-10006-B00	transformer	1
6	JK01-10030-000	tapping screw	6
7	DK20-10018-000	fixing board	2
8	DK20-10019-000	terminal	10
9	5301-00005-000	flat washer	4
10	JK01-10029-000	tapping screw	8
11	MK01-00105-000	rail	1
12	JK01-10010-100	fuse 1A	2
13	MK01-10008-B00	fuse 10A	2
14	DK09-10007-000	fuse seat	1
15	JK01-10009-001	fuse seat board	1
16	JK01-10009-000	fuse seat	2
17	5110-04004-000	tapping screw	2
18	MK01-00102-000	bridge rectifier	1
19	JK01-10031-000	tapping screw	2
20	JK01-10005-000	contactor	1
21	JK01-10020-000	cable ring	2
22	JK01-10014-000	earthling end	1
23	JK01-JD000-000	earthling sign	1
24	5301-00004-000	flat washer	2
25	5110-04004-000	tapping screw	2

## 7. Troubleshooting Guide

Problem	Cause	Solution
Motor does not run.	<ol style="list-style-type: none"> <li>1. Blown fuse or circuit breaker</li> <li>2. Incorrect voltage to motor</li> <li>3. Motor up switch burned out.</li> <li>4. Overhead limit switch burned out.</li> <li>5. Motor windings burned out.</li> </ol>	<ol style="list-style-type: none"> <li>1. Replace blown fuse or reset circuit breaker.</li> <li>2. Supply correct voltage to motor.</li> <li>3. Replace switch.</li> <li>4. Replace switch.</li> <li>5. Replace motor.</li> </ol>
Motor runs but will not raise lift.	<ol style="list-style-type: none"> <li>1. Open lowering valve.</li> <li>2. Pump sucking air</li> <li>3. Suction stub off pump.</li> <li>4. Low oil level</li> </ol>	<ol style="list-style-type: none"> <li>1. Repair or replace lowering valve.</li> <li>2. Tighten all suction line fittings.</li> <li>3. Replace suction stub.</li> <li>4. Fill tank with AW32 or AW46</li> </ol>
Motor runs-will raises unloaded lift but will not raise motorcycle.	<ol style="list-style-type: none"> <li>1. Motor running on low voltage</li> <li>2. Lowering valve loose.</li> <li>3. Relief valve opens in advance.</li> <li>4. Overloading lift</li> </ol>	<ol style="list-style-type: none"> <li>1. Supply correct voltage to motor.</li> <li>2. Clean lowering valve.</li> <li>3. Reset the pressure of relief valve.</li> <li>4. Check vehicle weight and/or balance vehicle weight on lift.</li> </ol>
Lift slowly settles down.	<ol style="list-style-type: none"> <li>1. Check valve is blocked.</li> <li>2. Lowering valve isn't opened fully.</li> </ol>	<ol style="list-style-type: none"> <li>1. Clean check valve.</li> <li>2. Clean lowering valve.</li> </ol>
Slow lifting speed	<ol style="list-style-type: none"> <li>1. Air mixed with oil.</li> <li>2. Suction stub looses</li> <li>3. Relief valve opens in advance</li> <li>4. Lowering valve looses</li> </ol>	<ol style="list-style-type: none"> <li>1. Change oil to AW32 or AW46</li> <li>2. Tighten all suction line fittings.</li> <li>3. Reset the pressure of relief valve</li> <li>4. Clean lowering valve</li> </ol>
Locking latches do not engage.	<ol style="list-style-type: none"> <li>1. Latch shafts rusted. (Usually occurs on outside installation or in high humidity areas such as vehicle wash bays.)</li> <li>2. Release the lock without lifting</li> <li>3. Cable broken or bad connection</li> </ol>	<ol style="list-style-type: none"> <li>1. Remove covers, oil latch mechanism. Depress latch release handle several times to allow oil to coat shaft.</li> <li>2. Lifting a short distance first.</li> <li>3. Check the cable or replace</li> </ol>

## LIMITED WARRANTY

### **Structural Warranty:**

The following parts and structural components carry a five year warranty:

Columns	Arms	Uprights	Swivel Pins
Legs	Carriages	Overhead Beam	
Tracks	Cross Rails	Top Rail Beam	

### **Limited One-Year Warranty:**

Tuxedo Distributors, LLC (iDEAL) offers a limited one-year warranty to the original purchaser of Lifts and Wheel Service equipment in the United States and Canada. Tuxedo will replace, without charge, any part found defective in materials or workmanship under normal use, for a period of one year after purchase. The purchaser is responsible for all shipping charges. This warranty does not apply to equipment that has been improperly installed or altered or that has not been operated or maintained according to specifications.

### **Other Limitations:**

This warranty does not cover:

1. Parts needed for normal maintenance
2. Wear parts, including but not limited to cables, slider blocks, chains, rubber pads and pulleys
3. Replacement of lift and tire changer cylinders after the first 30 days. A seal kit and installation instructions will be sent for repairs thereafter.
4. On-site labor

Upon receipt, the customer must visually inspect the equipment for any potential freight damage before signing clear on the shipping receipt. Freight damage is not considered a warranty issue and therefore must be noted for any potential recovery with the shipping company.

The customer is required to notify Tuxedo of any missing parts within 72 hours. Timely notification must be received to be covered under warranty.

Tuxedo will replace any defective part under warranty at no charge as soon as such parts become available from the manufacturer. No guarantee is given as to the immediate availability of replacement parts.

Tuxedo reserves the right to make improvements and/or design changes to its lifts without any obligation to previously sold, assembled or fabricated equipment.

There is no other express warranty on the Tuxedo lifts and this warranty is exclusive of and in lieu of all other warranties, expressed or implied, including all warranties of merchantability and fitness for a particular purpose.

To the fullest extent allowed by law, Tuxedo shall not be liable for loss of use, cost of cover, lost profits, inconvenience, lost time, commercial loss or other incidental or consequential damages.

This Limited Warranty is granted to the original purchaser only and is not transferable or assignable.

Some states do not allow exclusion or limitation of consequential damages or how long an implied warranty lasts, so the above limitations and exclusions may not apply. This warranty gives you specific legal rights and you may have other rights, which may vary from state to state.

1905 N Main St Suite C, Cleburne, TX 76033

Ph 817-558-9337 / Fax 817-558-9740