

151 INDUSTRIAL DRIVE  
ASHLAND, MISSISSIPPI 38603  
<http://www.tciauto.com>

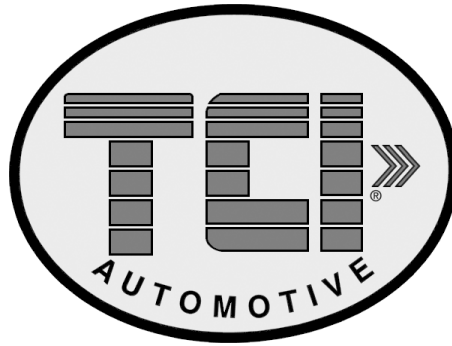

TELEPHONE: 662-224-8972  
FAX LINE: 662-224-8255  
E-MAIL: [tech@tciauto.com](mailto:tech@tciauto.com)

# ***Thunder Stick & Outlaw Shifter*** **Installation Instructions**

## ***Part Numbers 616131/611123 & 616331/611323***

The TCI® Thunder Stick shifter 616131 & Outlaw shifter 616331 come equipped with a three speed forward (standard) pattern gate that works with most popular three speed automatic transmissions. To use these shifters with a reverse pattern three speed automatic transmission or a two speed automatic transmission you will need an optional gate plate.

The TCI® Thunder Stick shifter 611123 & Outlaw shifter 611323 includes the two speed gate plate, a cable bracket and the Powerglide special lever without the throttle valve shaft hole. For use with trans-brakes and full manual valve bodies only.

An aluminum mounting bracket is available for the TCI® Thunder Stick shifter with quick release pins to allow the shifter to be removed and replaced quickly, or the shifter can be mounted directly to the floor. An aluminum housing is supplied or it can be purchased separately to provide a finished look to the shifter. The housing can be used either with or without the mounting bracket. The shifter comes equipped with a neutral safety switch, and an optional backup light switch is available.

The part numbers for the optional products are:

Three speed reverse pattern gate plate	<b>618013</b>
Four speed forward pattern gate plate	<b>618014</b>
Two Speed (Powerglide) gate plate kit	<b>618015</b>
Mounting bracket	<b>618003</b>
Aluminum housing	<b>618002</b>
Back up light switch	<b>618012</b>
Thunder Stick knob w/ 12V switch	<b>618004</b>
AOD installation kit	<b>618016</b>

The main mechanical components of this shifter are precision factory assembled. Any modification or disassembly of these parts can cause shifter malfunction

and will void the warranty. You should disassemble only that which is detailed in the instructions.

The vehicle should be 1-2 feet off the ground for ease of installation. Jack stands, wheel ramps or a hoist will work fine. Make sure the vehicle is firmly supported. Read through these instructions before beginning installation. If you do not understand a particular step at first, go back and re-read the step before proceeding.

**Warning:** If your vehicle is equipped with a locking steering column, securing the column lock lever in the engine compartment in the full up position will allow the wheel to lock and unlock but will allow the key to lock the wheel if the key is turned to 'lock' while moving, or at any time. Securing the lock lever in any other position will prevent the wheel from locking at any time.

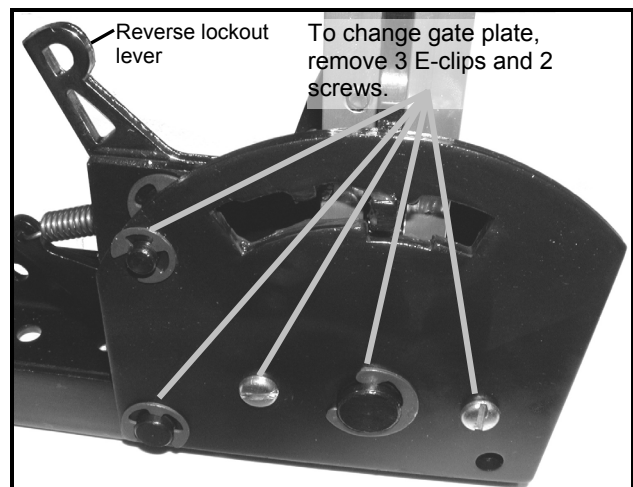

**Figure 1**

**Step 1.** Remove the stock shift linkage:

If you are going to use a different gate plate on the shifter, change it now. Remove the two screws and three E-clips that hold the gate plate on (**See Figure 1**).

Remove the original gate plate and install the new gate plate. Replace the E-clips and the screws.

**Column Shifters:** Remove all rods, levers or cables from the column and the transmission. Place the column shifter lever in the park position. Remove the roll pin holding the shift lever to the column and remove the shift lever assembly.

**Console Shifters:** Remove the shifter mechanism from the console. Disconnect and remove the rod or cable from the transmission if so equipped. **Note:** Shifter installation may require console modification or complete console removal depending on your vehicle and available space.

**Step 2.** If so equipped, pull the carpet away from the floorboard where the shifter is to be mounted. Locate the shifter in the vehicle with the stick shifted to the rearmost gate position and mark the position of the four mounting holes in the floor.

**Step 3.** Remove the shifter mechanism and drill four mounting holes using a 9/32" drill bit. Mark the position of the shifter cable hole. The cable hole must be 1 inch in diameter. Drill or cut the cable hole in the floorboard.

**Step 4.** Install the carpet back to the original position. Do not secure the carpet at this time. Cut holes in the carpet at the mounting hole position. Cut a 1-inch slit in the carpet at the cable hole position.

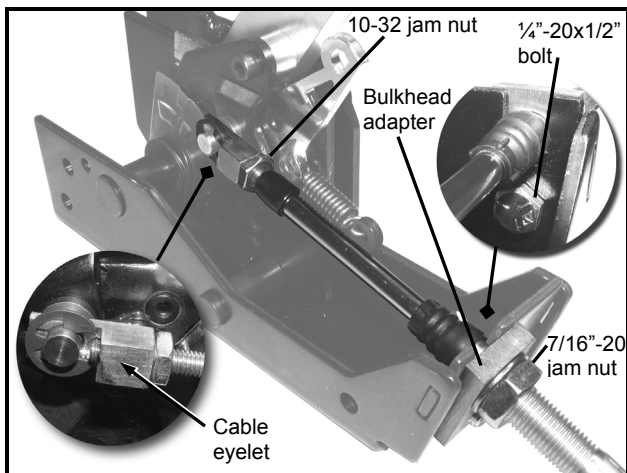

**Figure 2**

**Step 5.** Install the cable onto the shifter mechanism. Both ends of the TCI® cable are the same. Begin by removing the 10-32 jam nut and two rubber dust boots from one end of the cable. Also remove one 7/16"-20 jam nut and washer.

Thread the bulkhead adapter onto the cable until it stops and secure with the 7/16"-20 jam nut as shown in **Figure 2**. Replace the two rubber dust boots and 10-32 jam nut on the cable. Fit the cable housing into the U-shaped notch in the shifter mechanism and fasten the bulkhead adapter with the supplied 1/4"-20x1/2" bolt to the outside of the

shifter frame. (**See Figure 2**) Use a liquid thread locking compound or supplied lock washer to keep the bolt tight.

Thread the cable eyelet onto the end of the cable until two threads protrude from the opposite side as seen in **Figure 2**. Tighten the 10-32 jam nut against the eyelet and install the E-clip to retain the cable. Use cable clamps or tie-wraps to secure the cable to avoid contact with hot engine or exhaust system.

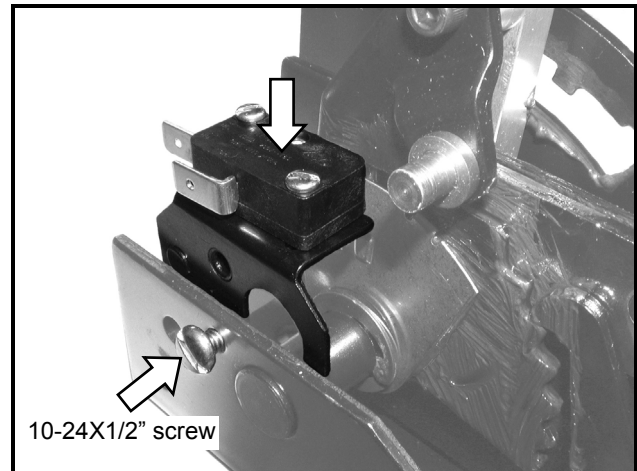

**Figure 3**

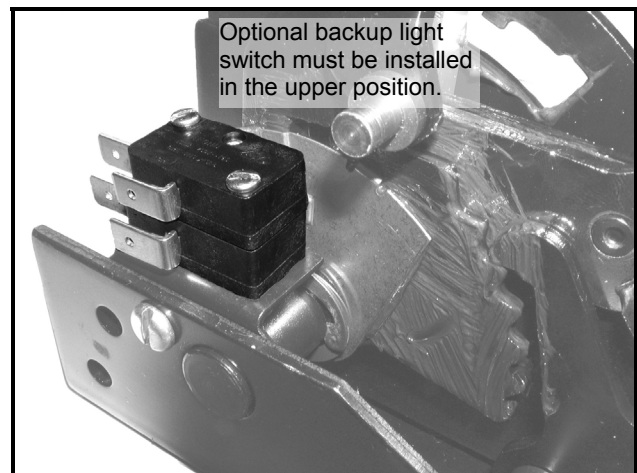

**Figure 4**

**Step 6.** Install the neutral safety switch in place on the switch bracket (**See Figure 3**). Install two #4-40 x 5/8" screws through the switch and the bracket. Install a lock washer and a nut on each screw and tighten snugly. (If you are installing an optional back up light switch, it must be installed on top of the neutral safety switch as shown in **Figure 4**). Do not over tighten the nuts as you may crack the switch. Install the switch bracket assembly on the shifter base with a 10-24 x 1/2" pan head screw. If required, you can adjust the switch relative to the switch actuator plate.

**Step 7.** Install the shifter mechanism into the vehicle. Slide the shifter cable through the carpet and the cable hole in the floor. The shifter mechanism should be level when installed. Make sure the cable is routed according to **Figure 5** to avoid sharp bends or damage to the cable. Install the 1/4"-20x1-

1/2" bolts, washers, and nuts (supplied) through the shifter and the floorboard and tighten securely. **Note:** Some floorboards are extremely thin and will not adequately support the shifter mechanism when bolted to the floor, resulting in excessive shifter wobble. For those vehicles, we recommend you fabricate a stiffener plate for additional strength. Seal the cable hole securely to prevent entry of exhaust gases.

**GM Vehicles: go to Step 8.**

**Ford Vehicles: go to Step 13.**

**Chrysler Vehicles: go to Step 19.**

**Powerglide Equipped Vehicles: go to Step 25.**

### GENERAL MOTORS

**Step 8.** If you have not already done so, remove the stock selector lever nut and the selector lever from the transmission. Discard the stock lever and the stock shifter linkage. Install the TCI® selector lever in position using the stock selector lever nut (**See Figure 6**). Torque the nut to 23 lbs.-ft. The lever should move smoothly from front to rear with a positive click in each gear position.

**Step 9.** Remove the two transmission oil pan bolts from the middle of the left side of the oil pan. Install the cable bracket in position (**See Figure 6**). The bracket must be installed with two spacers between the pan and the bracket. (If your transmission is equipped with a cast aluminum oil pan, these spacers should be omitted. With a TH400 with a cast aluminum oil pan the cable bracket may have to be modified.) Install the two 5/16-18 x 1.00" bolts (Metric transmissions use the two 8mm x 25mm bolts) supplied and tighten 12-13 lbs.-ft. Do not over tighten as this can damage the pan gasket.

**Step 10.** Route the shifter cable according to **Figure 5**. Avoid kinks and sharp bends and route the cable away from hot engine or exhaust parts. Remove the two rubber

boots, one large nut, and a large lock washer from the threaded end of the shifter cable. Slide the end of the cable into the cable bracket. Install the large nut and the lock washer loosely over the end of the cable. Install the two rubber boots onto the end of the cable. Install the swivel on the threaded end of the cable and position it in the center of the threaded portion.

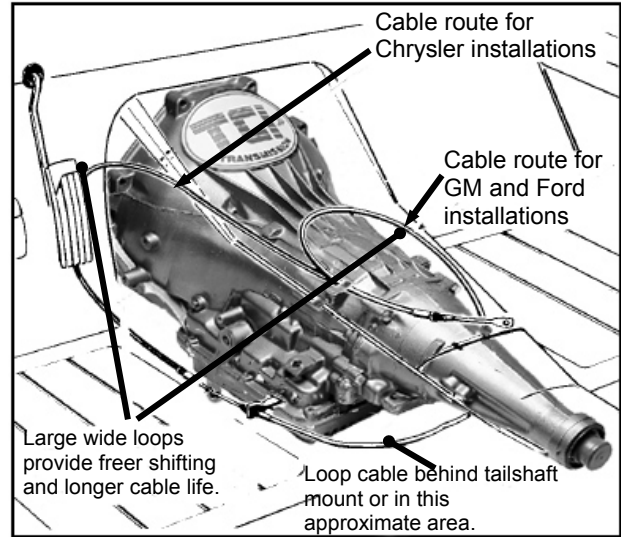

**Figure 5**

**Step 11.** Move the transmission selector lever by hand to the full rear position (Low). Operate the shifter lever to the Low gear position (all the way back). Adjust the large nuts on the cable so that the swivel will slide into the **front** hole on the selector lever. Tighten the large nuts completely. Be sure that the swivel will slide freely in and out of the hole in the selector lever. **Note:** The shifter will not operate correctly unless the **front** hole in the shift lever is used. Leave the swivel out of the hole and move the selector lever to Park,

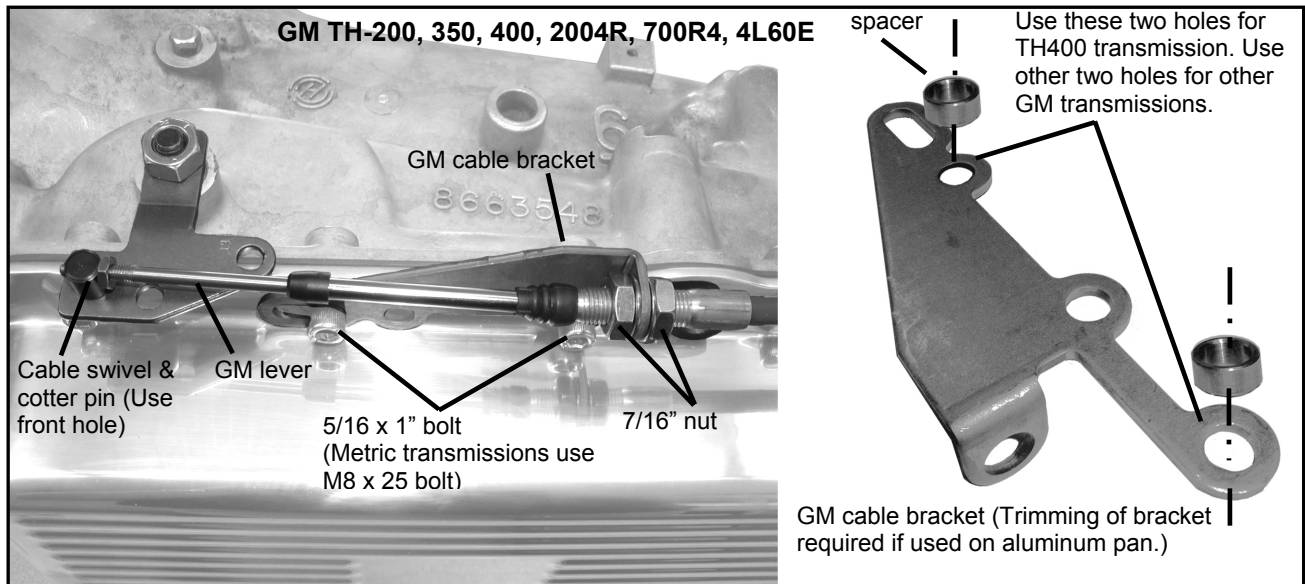

**Figure 6**

all the way forward. Also move the shifter to the Park position (all the way forward). Reinsert the swivel into the **front** hole in the selector lever. Check to see that the swivel will slide freely in and out of the **front** hole in the selector lever in this position. If it does not slip in freely, adjust the swivel slightly until it will slip into the hole in the lever. Move the shifter back to the Low gear position and check that the swivel will still slide easily in and out of the **front** hole in the selector level. (If you do not use the **front** hole in the lever, it will be impossible to correctly adjust the cable.) Operate the shifter through all the gear positions. Check to make sure the swivel will slide in and out of the **front** selector lever hole in each gear position. The shift cable is now correctly adjusted. Install the cotter key supplied with the shifter into the swivel and spread the key ends. If you have a problem, **DO NOT FORCE THE SHIFTER**, this will damage the cable, the shifter or the transmission. Simply start at the beginning and carefully check all your steps.

**Step 12.** On GM vehicles the neutral safety switch may be located on the shifter (steering column or console), or it may be a mechanical interlock in the steering column that prevents the key from turning to the Start position unless the shifter is in the Park or Neutral position. Identify the type of neutral safety system you have. If the key will not turn to the Start position unless the stock shifter is in Park or Neutral, you have a mechanical interlock type; otherwise you have a neutral safety switch type. If you have a neutral safety switch, locate the switch and identify the neutral safety wires (engine will not crank unless these wires are connected together). With either type, disconnect the battery ground cable to prevent accidental shorts. If you have a neutral safety switch, disconnect and extend both wires from the GM switch to the switch on the shifter. If you have a mechanical interlock cut the wire that goes from the Start position on the ignition switch to the solenoid on the starter. This wire is usually a 10 or 12 gauge purple wire. Run wires from both ends of the cut wire to the switch on the shifter. Put slip on terminals on the ends of the lengthened wire. Crimp the terminals onto the wires using a crimping tool or pliers. Connect the wires to the switch on the shifter. Tape the terminal connections and all other connections to prevent shorts. Reconnect the battery ground cable, disconnect the coil wire and set the parking brake. Check the switch operation by attempting to start the motor in each shifter position. The starter must crank only when the shifter is in the Park or Neutral position. Adjust the switch if required. Reconnect the coil wire.

### FORD

**Step 13.** If you have not already done so, remove the nut and lock washer holding the downshift linkage onto the downshift lever shaft. The downshift lever is the outer lever on C4, C5, C6 and AOD transmissions. Pull the lever off the shaft and allow the linkage to hang free. Remove and discard the stock shift linkage rods. Some C6 and all (late) C4 and C5 transmissions have a neutral safety/backup light switch on the transmission shift lever. If your transmission is so equipped, remove the two bolts holding the switch in place and slide it off the shift shaft. Disconnect the switch at the factory plug and discard it.

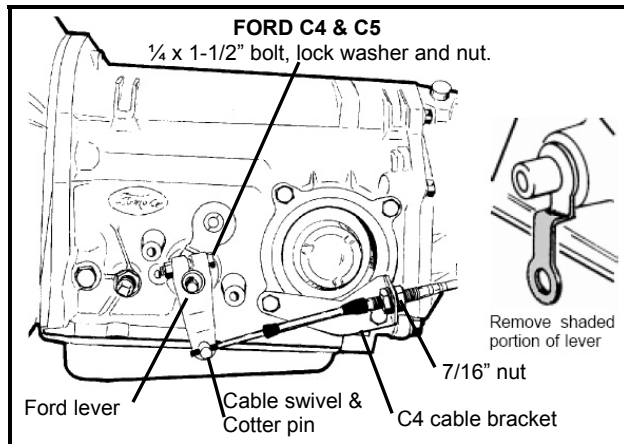

Figure 7

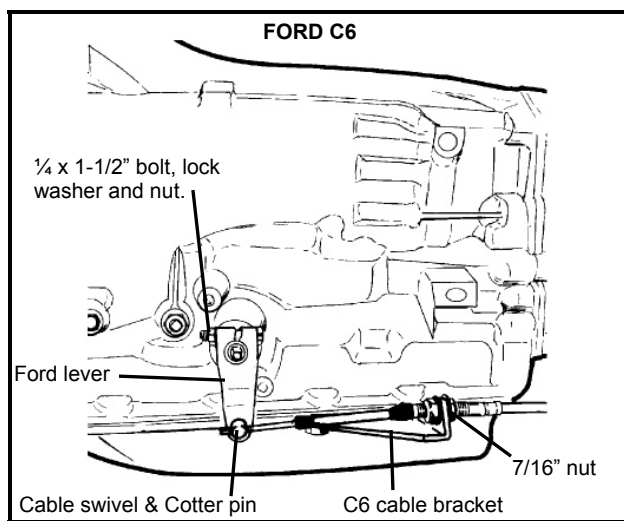

Figure 8

**Step 14.** Install the TCI® selector lever (See Figure 7 or 8). **Note:** The TCI® lever must point downward for proper operation. If the stock shift lever on your transmission points down, you will have to remove the lower part of the stock arm by cutting it off to clear the TCI® lever (See Figure 7). Install the TCI® selector lever onto the shift shaft of the transmission. Align the selector lever so when it points straight down it travels equal arcs in both directions from the center, then tighten the 1/4"-20 x 1 1/2" pinch bolt and nut. The lever should travel smoothly from front to back with a positive click in each gear position. Make sure the O-ring is in position on the downshift shaft and install the downshift lever in position on the shaft. Install the lock washer and nut and tighten securely. The downshift lever must operate smoothly. Reconnect the downshift linkage.

**Step 15.** Cable bracket installation: AOD: Instructions for the AOD are included with the optional installation kit, Part # 618016. C4, C5: Remove the two lower bolts from the rear servo cover. Install the cable bracket in position (See Figure 7). Install the two servo cover bolts as removed and tighten 12-13 lbs.-ft. Do not over tighten as this can distort the servo cover. C6: Remove the two transmission oil pan bolts from the left rear corner of the oil pan. Install the cable bracket in position with two spacers between the pan and the bracket.

(If your transmission is equipped with a cast aluminum oil pan, these spacers can be omitted.) Install the two 5/16-18 x 1.00" bolts supplied and tighten 12-13 lbs.-ft. Do not over tighten as this can damage the pan gasket.

**Step 16.** Route the shifter cable according to **Figure 5**. Avoid kinks and sharp bends and route the cable away from hot engine or exhaust parts. Remove the two rubber boots, one large nut, and a large lock washer from the threaded end of the shifter cable. Slide the end of the cable into the cable bracket; install the large nut and lock washer loosely over the end of the cable. Install the two rubber boots onto the end of the cable. Install the swivel on the threaded end of the cable and position it in the center of the threaded portion.

**Step 17.** Above the transmission selector lever by hand to the full rear position (Low). Place the shifter lever to the Low gear so that the swivel will slide into the hole on the selector lever. Tighten the large nuts completely. Be sure that the swivel will slide freely in and out of the hole in the selector lever. With the swivel in the selector lever, move the shifter to the Park position, as far forward as the shifter will go without forcing it. (The shifter has further travel that is used to reach the GM Park position but is not used on the Ford transmissions. Trying to force the cable will damage the cable.) The shift lever on the transmission should be all the way forward. Check to see that the swivel will slide freely in and out of the hole in the lever in this position. If it does not slip in freely, adjust the swivel slightly until it will slip into the hole in the lever in both the Low and Park positions. Operate the shifter through all the gear positions. Check to make sure the swivel will slide in and out of the selector lever hole in each gear position. Install the cotter key supplied with the shifter into the swivel and spread the key ends. If you have a problem, **DO NOT FORCE THE SHIFTER**, this will damage the cable, the shifter or the transmission. Simply start at the beginning and carefully check all your steps. **IMPORTANT:** Do not force the shifter to over-travel into the Park position. This will move the shifter into the GM Park position and will damage the cable or transmission.

**Step 18.** On Ford vehicles, the neutral safety/backup light switch is located on the transmission (or on the steering column on some early vehicles). If the vehicle has an AOD transmission the neutral safety/backup light switches on the TCI® Thunder Stick shifter will **NOT** be used. The neutral safety/backup light switch on the AOD transmissions will continue to function normally. On the C4 and C5 transmissions it is necessary to completely remove the stock neutral safety/backup light switch in order to install the TCI® transmission shift lever. On C4, C5 and C6 transmissions, it will be necessary to hook up the neutral safety/backup light switches on the TCI® Thunder Stick shifter. Locate and identify the neutral safety (the engine will not crank unless these wires are connected together), and reverse light wires. Disconnect the battery ground cable before beginning to wire the neutral safety and reverse light switches. Reroute the wires to the TCI® Thunder Stick shifter. Strip 1/4" insulation off the wires and

install the supplied slip on terminals. Crimp the terminals onto the wires to the LOWER switch and the reverse light wires to the UPPER switch (**See Figure 4**). Tape the terminal connections to prevent shorts. Reconnect the battery ground cable, disconnect the coil wire and set the parking brake. Check the switch operation by attempting to start the motor in each shifter position. The starter must crank only when the shifter is in the Park or Neutral position. Check the backup light operation when the shifter is shifted to the Reverse position. Adjust the switches if required. Reconnect the coil wire.

## CHRYSLER

**Step 19.** If you have not already done so, loosen the pinch bolt on the throttle lever on the transmission. This is the lever on the small diameter shaft. Pry the lever off with a screwdriver and allow the linkage to hang free. Remove and discard the stock shift lever and tighten the pinch bolt securely (**See Figure 9**). Make sure the lever is not pushed down so far as to touch the transmission; it should travel smoothly from front to back with a positive click in each gear position. Install the stock throttle lever in position on the small diameter shaft as removed and tighten the pinch bolt securely. The throttle lever must operate smoothly.

**Step 20.** Remove the two transmission oil pan bolts directly below the shift lever. Install the cable bracket in position (**See Figure 9**) with two spacers between the pan and the bracket. (If your transmission is equipped with a cast aluminum oil pan these spacers can be omitted.) Install the two 5/16-18 x 1.00" pan bolts supplied and tighten to 12-13 lbs.-ft. Do not over tighten as this can damage the pan gasket.

**Step 21.** Route the shifter cable according to **Figure 5**. Avoid kinks and sharp bends and route the cable away from hot engine or exhaust parts.

Remove the two rubber boots, one large nut, and a large lock washer from the threaded end of the shifter cable. Slide the end of the cable into the cable bracket. Install the large nut and lock washer loosely over the end of the cable. Install the two rubber boots onto the end of the cable. Install the swivel on the threaded end of the cable and position it in the center of the threaded portion.

**Step 22.** Move the transmission selector lever by hand to full forward position (Low). Place the shifter lever to the Low gear position (all the way back). Adjust the large nuts on the selector lever. Tighten the large nuts completely. Be sure that the swivel will slide freely in and out of the hole in the selector lever. With the swivel in the selector lever, move the shifter to the Park position, as far forward as the shifter will go without forcing it. (The shifter has further travel that is used to reaching the GM Park position but is not used on the Chrysler transmissions. Trying to force the shifter will damage the cable.) The shift lever on the transmission should be all the way back. Check to see that the swivel will slide freely in and out of the hole in the lever in this position. If it does not slip in freely, adjust the swivel slightly until it will slip into the hole in the lever in both the Low and Park

positions. Operate the shifter through all the gear positions. Check to make sure the swivel will slide in and out of the selector lever hole in each gear position. Install the cotter key supplied with the shifter into the swivel and spread the key ends. If you have a problem **DO NOT FORCE THE SHIFTER**, this will damage the cable, the shifter, or the transmission. Simply start at the beginning and carefully check all your steps. **Important:** Do not force the shifter to over-travel into the Park position. This will move the shifter into the GM Park position and will damage the cable or transmission.

**Step 23.** Check the operation of throttle linkage again. The linkage must operate smoothly with no bind. All transmissions using automatic valve bodies must have the throttle linkage connected and operating or transmission damage will result.

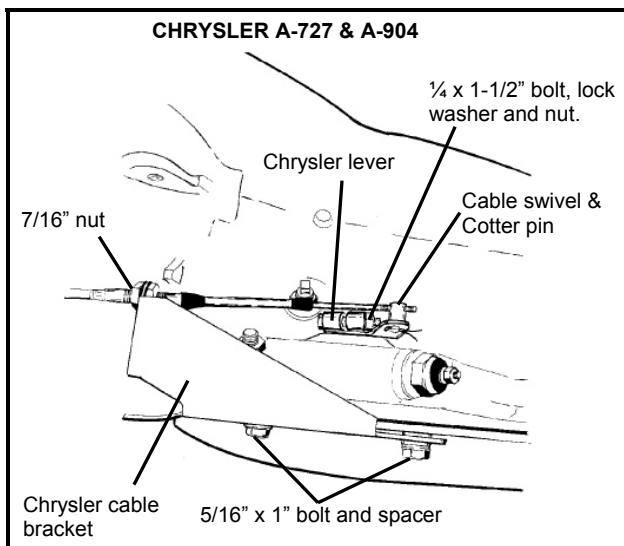

**Figure 9**

**Step 24.** Neutral safety/backup light switch. 1966-1968: The neutral safety switch will continue to function normally. It will not be necessary to hook up the neutral safety switch wires on the shifter. Disconnect the battery ground cable before wiring the backup light switch. Locate the original backup light switch on the steering column or console shifter. Run these wires to the top switch on the TCI® Thunder Stick. Reconnect the ground wire and check the light for proper operation. Adjust the switches on the shifter if required. 1969 and Later: The neutral safety/backup switch is located on the transmission and will continue to function normally. It will not be necessary to connect any wires to the switches on the shifter.

#### POWERGLIDE

**Step 25.** Disconnect the throttle to transmission linkage if any and discard. The Powerglide shift lever supplied with this shifter has no provision for a throttle linkage.

**Step 26.** Drain the transmission oil pan. **Caution:** Be sure the transmission is cool before attempting to drain the oil. Place the drain pan under the transmission. Remove the drain plug if so equipped. If your pan does not have a drain plug remove the oil pan bolts one at a time working towards

the front. As you loosen the last bolts the oil pan will tilt down and allow the oil to drain. **Note:** If your oil pan sticks to the gasket pry it down with a screwdriver before loosening the last two bolts to break it free. Remove the oil pan and set it aside.

**Step 27.** Remove the manual valve guide plate by removing two bolts (**See Figure 10**). Unhook and remove the detent roller spring. Allow the detent roller to pivot out of the way. Note how the pin on the manual valve selector engages the groove in the manual valve.

**Step 28.** If your transmission has a throttle valve lever on the outside of the shift lever loosen the inner pinch bolt on the throttle level. Slide the throttle lever and shaft out of the transmission. Remove the inner throttle valve lever. Discard these parts.

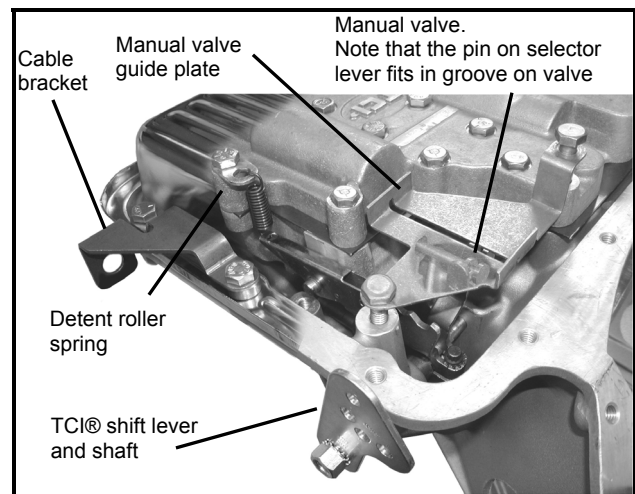

**Figure 10**

**Step 29.** Loosen the pinch bolt on the selector lever. This can be either an Allen head bolt of a 12-point bolt head. Do not remove the pinch bolt. Slightly pry the manual valve lever and slide the selector shaft from the transmission. Discard the selector shaft.

**Step 30.** This transmission includes a TCI® Powerglide shift lever which is a two-piece assembly with separate lever and shaft. Install the TCI® selector shaft into the transmission with the lever pointing down. Hold the stock selector lever in position in the case, engage the pin on the selector lever with the manual valve and rotate the TCI® shaft until the flat on the shaft engages the serrations on the lever. Push the TCI® lever firmly into the transmission until the lever stops on the shoulder of the shaft. Tighten the pinch bolt securely.

**Step 31.** Install the manual valve guide plate in place. (Make sure that pin on the selector lever is engaged in the groove in the manual valve.) Install the two bolts and tighten to 15 lbs.-ft. Install the detent roller spring. Hook the spring to the detent roller and tab. The selector lever must travel freely and smoothly from front to back with a positive click in each gear position.

**Step 32.** Clean the oil pan and scrape the old gasket off of the pan and case. (**Note:** If your pan does not have a drain plug, you may wish to install a TCI® Drain Plug Kit 805800, at this time.) The old gasket can cause leaks. Install the oil pan with the new gasket. Install the pan bolts except for the

two center bolts on the left side of the pan. Tighten the pan bolts to 8 lbs.-ft. Do not over tighten as this can damage the pan gasket.

**Step 33.** Install the cable bracket in position with the two remaining pan bolts (See Figure 10). Install the TCI® lever onto the shaft with the lever pointing down. If your cable comes from the front (usually a rear engine car), the lever is installed pointing upwards. You will have to make your own cable bracket for this installation.

**Step 34.** Route the shifter cable according to Figure 5. Avoid kinks and sharp bends and route the cable away from hot engine or exhaust parts.

Remove the two rubber boots, one large nut, and a large lock washer from the threaded end of the shifter cable. Slide the end of the cable into the cable bracket, install the large nut and lock washer loosely over the end of the cable. Install the two rubber boots onto the end of the cable. Install the swivel on the threaded end of the cable and position it in the center of the threaded portion.

**Step 35.** Move the transmission selector lever by hand to full rear position (Low). Operate the shifter lever to the Low gear position (all the way back). Adjust the large nuts on the cable so that the swivel will slide into the hole in the selector lever that is labeled 'H' (See Figure 11). Tighten the large nuts completely. Be sure that the swivel will slide freely in and out of the hole in the selector lever. **Note:** The shifter will not operate correctly unless the hole marked 'H' in the shift lever is used. Leave the swivel out of the hole and move the selector lever to the Park position (all the way forward). Reinsert the swivel into the hole marked 'H' in the selector lever. Check to see that the swivel will slide freely in and out of the hole marked 'H' in the lever. Move the shifter back to the Low gear position and check that the swivel will still slide easily in and out of the hole marked 'H' in the selector lever. (If you do not use the hole marked 'H' in the lever, it will be impossible to correctly adjust the cable.) Operate the shifter through all the gear positions. Check to make sure the swivel will slide in and out of the hole marked 'H' selector lever hole in each gear position. The shift cable is now correctly adjusted. Install the cotter key supplied with the shifter into the swivel and spread the key ends. If you have a problem, DO NOT FORCE THE SHIFTER, this will damage the cable, the shifter, or the transmission. Simply start at the beginning and carefully check all your steps.

**Step 36.** Disconnect the battery ground cable to prevent accidental shorts. Identify the neutral safety wires (engine will not crank unless these wires are connected together). Extend the wires to the shifter. Strip 1/4" insulation off the wires and in-stall slip-on terminals supplied in kit. Crimp the terminals onto the wires using a crimping tool or pliers. Connect the neutral safety wires to the LOWER switch and the back up light wires to the UPPER switch (See Figure 4).

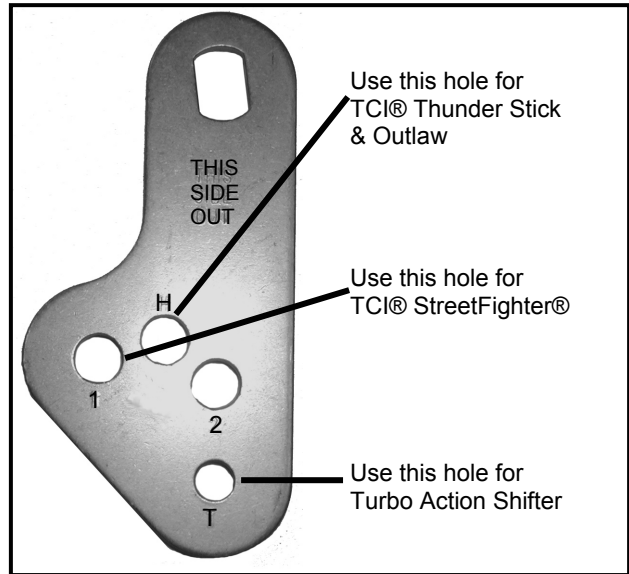

Figure 11

Tap the terminal connections and all other connections to prevent shorts. Reconnect the battery ground cable, disconnect the coil wire and set the parking brake. Check the switch operation by attempting to start the motor in each shifter position. The starter must crank only when the shifter is in the Park or Neutral position. Check the backup light operation when the shifter is shifted to the Reverse position. Adjust the switches if required. Reconnect the coil wire.

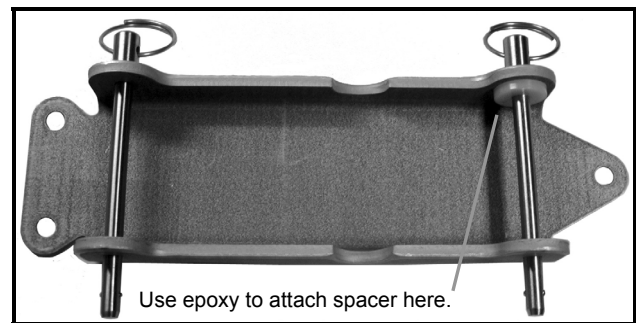

Figure 12

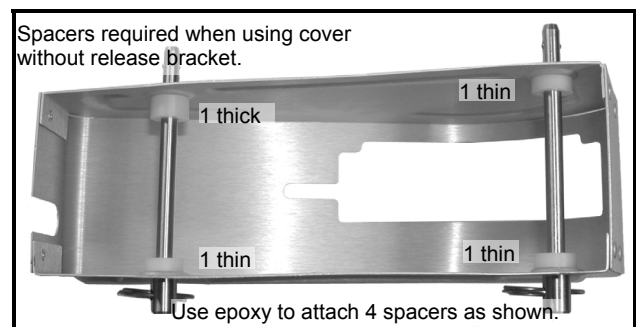

Figure 13

**MOUNTING BRACKET AND ALUMINUM HOUSING**

If the optional, quick-release mounting bracket is being used, it is screwed to the floor with three mounting screws. One spacer washer is required between the mounting bracket and the shifter in the location shown in Figure 10.

The shifter is held onto the bracket with the two quick release pins.

The aluminum housing can be used with or without the mounting bracket. If it is used with the mounting bracket, no spacers are required. If it is used without the mounting bracket, four spacer washers are required between the shifter and the cover as shown in **Figure 13**. The two quick release pins are used to hold the cover to the shifter or the shifter and mounting bracket.

## OPERATION

### How to shift Thunder Stick/Outlaw Shifter

**Note:** The Reverse Lockout Lever (See **Figure 1**) described in the following instructions **ONLY** needs to be operated when shifting from Neutral to Reverse.

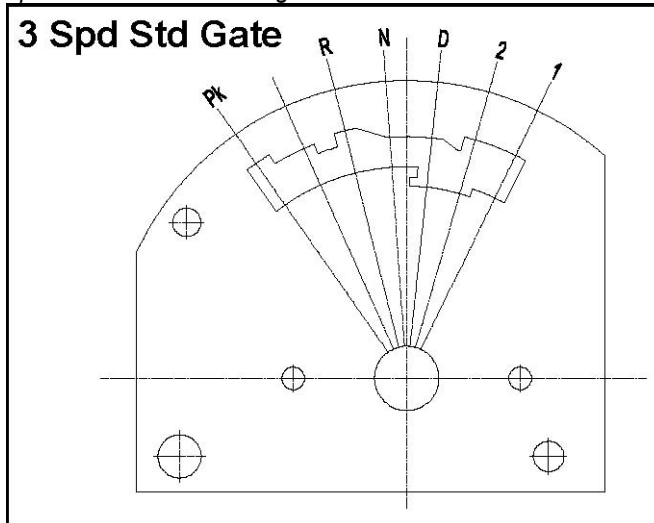

**Figure 14**

### THREE SPEED FORWARD PATTERN (See Figure 14)

- 1. First Gear:** (Starting with the shifter in Park) Pull the trigger lightly until it stops, then pull the stick all the way back releasing the trigger at mid travel.
- 2. Second Gear:** Push the stick forward to stop.
- 3. Third Gear:** Pull and hold the trigger firmly, then push the stick forward to stop. Release the trigger and remove the pressure from the stick allowing the spring loaded selector pin to raise to the top of the gate opening.
- 4. Neutral:** Push the stick forward to stop.
- 5. Reverse:** Push the Reverse Lockout lever forward, then push the stick forward to stop.
- 6. Park:** Pull and hold the trigger lightly until it stops, then while holding pressure on the trigger push the stick forward until it stops.

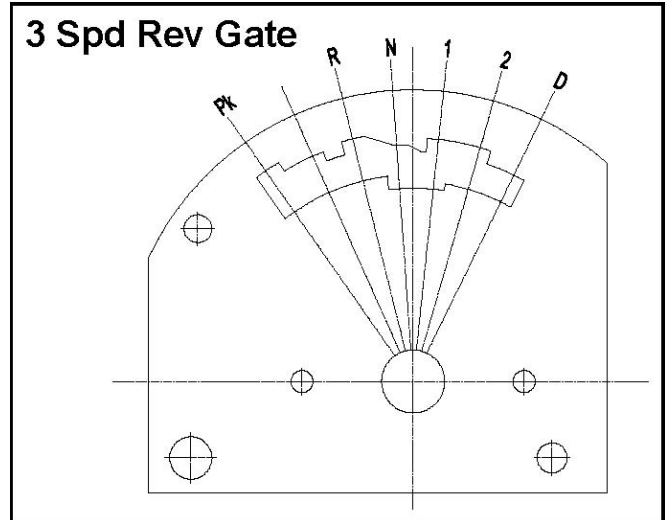

**FIGURE 15**

### THREE SPEED REVERSE PATTERN (See Figure 15)

- 1. First Gear:** (Starting with the shifter in Park) Pull the trigger lightly until it stops, then while holding the pressure on the trigger pull the stick rearward slowly until the stick stops at the '1' position.
- 2. Second Gear:** Pull the stick rearward against the stop.
- 3. Third Gear:** Pull the trigger lightly until it stops, then while holding pressure on the trigger pull the stick rearward until it stops.
- 4. Neutral:** From Third, Second, or First. Pull the trigger lightly until it stops, then while holding pressure on the trigger push the stick forward until it stops.
- 5. Reverse:** Push the Reverse Lockout lever forward, then push the stick forward until it stops.
- 6. Park:** Pull the trigger lightly until it stops, then while holding pressure on the trigger push the stick forward until it stops.

### TWO SPEED FORWARD PATTERN (See Figure 16)

- 1. Low:** (Starting with the shifter in Park) Pull the trigger lightly until it stops, then while holding pressure on the trigger pull the stick all the way back releasing the trigger at mid travel.
- 2. Drive:** Push the stick forward until it stops.
- 3. Neutral:** Pull the trigger firmly until it stops, then push the stick forward until it stops. Release the trigger.
- 4. Reverse:** Push the Reverse Lockout lever forward, then push the stick forward until it stops.
- 5. Park:** Pull the trigger lightly until it stops, then while holding pressure on the trigger push the stick forward until it stops.

### TWO SPEED REVERSE PATTERN (See Figure 16)

- 1. Low:** (Starting with the shifter in Park) Pull the trigger lightly until it stops, then while holding pressure on the trigger, pull the stick rearward slowly until it stops at the "L" position.
- 2. Drive:** Pull the stick rearward until it stops.



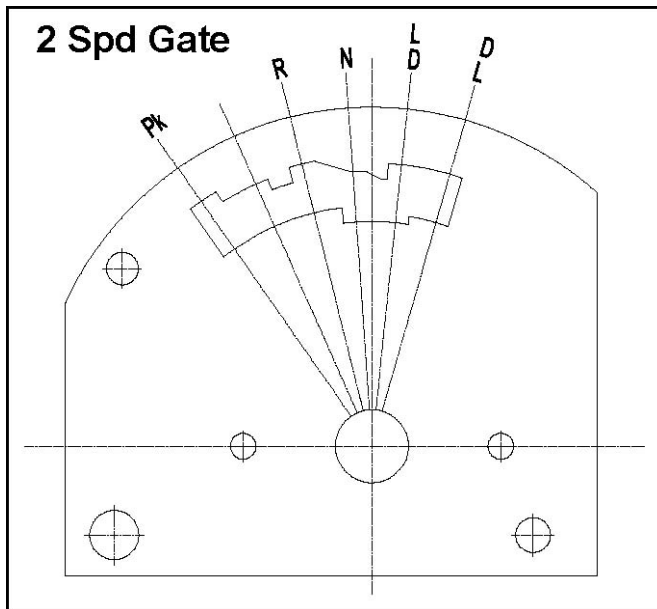

Figure 16

**3. Neutral:** Pull the trigger lightly until it stops, then while holding pressure on the trigger, push the trigger forward until it stops at the "N" position. Release the trigger.

**4. Reverse:** Push the Reverse Lockout lever forward, and then push the stick forward until it stops.

**5. Park:** Pull the trigger lightly until it stops, then while holding pressure on the trigger push the stick forward until it stops.

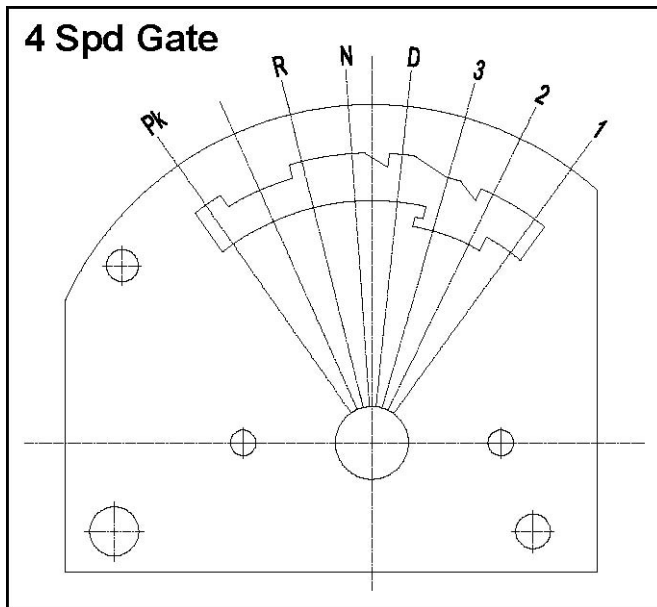

Figure 17

**FOUR SPEED FORWARD PATTERN (See Figure 17)**

**1. First Gear:** (Starting with the shifter in Park) Pull the trigger lightly until it stops, then pull the stick all the way back releasing the trigger at mid travel.

**2. Second Gear:** Push the stick forward until it stops.

**3. Third Gear:** Pull and hold the trigger firmly, then push the stick forward until it stops. Release the trigger and remove pressure from the stick allowing the spring loaded selector pin to raise to the top of the gate opening.

**4. Fourth Gear:** Push the stick forward until it stops.

**5. Neutral:** Pull the trigger and push the stick forward until it stops. Release the trigger.

**6. Reverse:** Push the Reverse Lockout lever forward, then push the stick forward until it stops.

**7. Park:** Pull the trigger lightly until it stops, then while holding pressure on the trigger, push the stick forward until it stops.

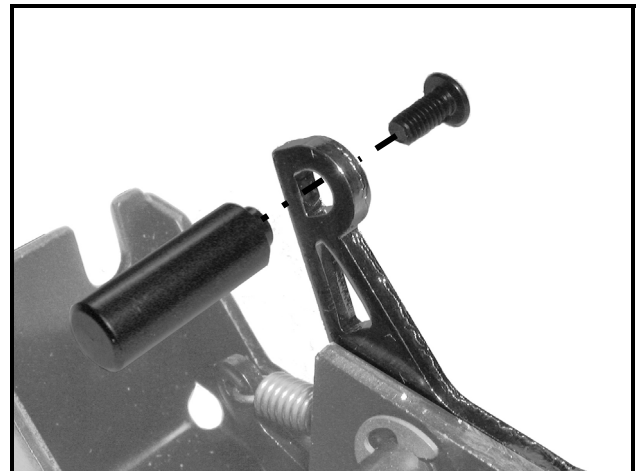
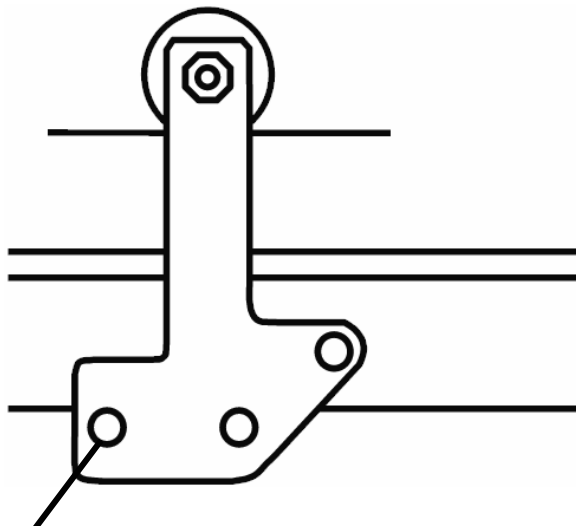

Figure 18

An extender handle for the reverse lockout lever is included with your new Thunder Stick shifter. This handle allows easier access to the reverse lockout, particularly in a race car while wearing belts and gloves. If you wish to use this extender handle, insert the handle from the left side of the shifter through the center of the 'R' shape of the reverse lockout lever and secure it with the machine screw provided. **See Figure 18.** Use thread-locking compound on the threads.

**Warning** Periodic inspection and maintenance of your shifter is recommended to ensure that the mechanism is well lubricated, free from dirt or rust and that the cable is properly adjusted. Lack of maintenance could result in a failure including a failure of the reverse lockout safety feature.

**GM TH200, 350, 400, 2004R  
& 700R4 lever shown.**



Outlaw, Thunder  
Stick, StreetFighter®

**INSTALLATION**

**Note:** Be careful. Select the correct hole for your shifter. Wrong hole will destroy the cable, shifter and/or transmission in one shift! (GM transmission only.)

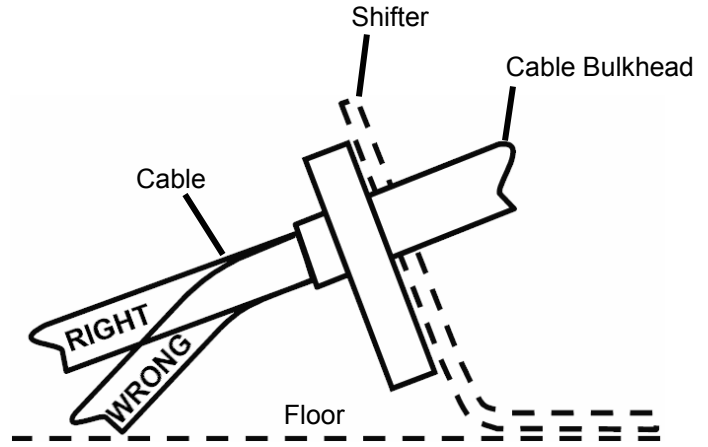

**DO NOT KINK CABLE**

**Note:** Do not kink cable anywhere along its length. If cable has a kink, it will lock up. Cable should be kept straight for two inches on each end where it leaves the bulkhead. Any of the above will destroy the cable and/or shifter in one shift!

# Warning!

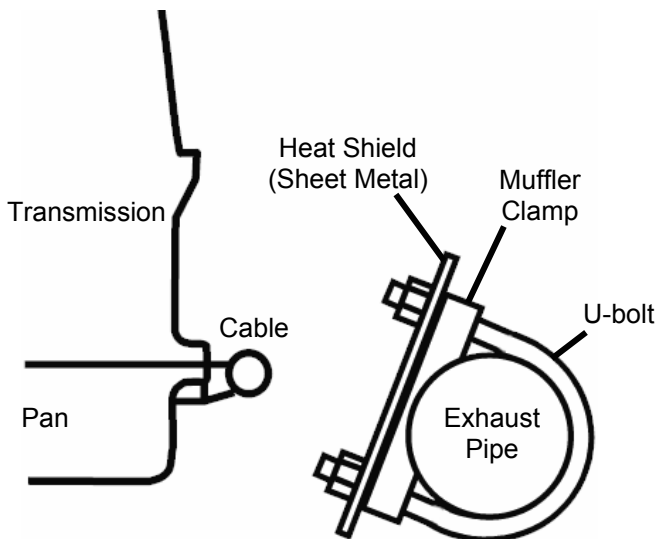

**MELTED CABLES**

**Note:** If your cable is close to your exhaust it will melt or become brittle. If this is the case, you will need to make a heat shield. Do not wrap the cable; this retains heat. Heat will destroy the cable!

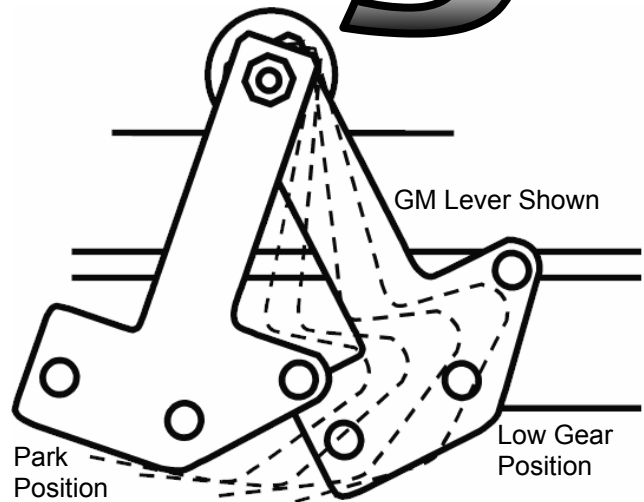

**CABLE ADJUSTMENT**

**Note:** If you don't adjust the cable correctly, you will destroy the cable, shifter and/or transmission in one shift! Put the transmission in low gear and the shifter in low gear. Set the swivel so it slides in and out of the correct hole freely (see installation picture). Then move the transmission and shifter to Park (all the way the other way) then rotate the cable swivel until it slips in and out of the hole freely. Now go back and forth between Park and Low gear and fine-tune the adjustment. See instructions for further details.