



# 4L80E-3 Reprogramming Kit®

## Features: Total Driver Control!

### No Automatic Shifts

The trans will be in the gear you select and changes to any gear you choose when you move the selector.

**DRIVER is in full COMMAND!**

### Gas engines only!



*OE pan gasket is required  
& is not furnished in kit.  
See page 8 for data.*

This is the heavy duty trans that trucks and high horsepower street rods have been waiting for. Just the ticket for conversions.

## Burnouts:

In water or bleach box: Break it loose in 1st/2nd, then up-shift to 3rd.

THESE ARE THE TRANSMISSION RATIOS:

"1st" 2.48 "2nd" 1.48 "3rd" 1.00 "4th" .75

To find top gear ratio, multiply the axle ratio x .75 [Example 3.73 x .75 = 2.79] Other ratios: Multiply axle ratio x trans ratio. [Example 3.73 x 2.48 = 9.25]



**Mr. Shift**  
"Thanks for Listening"

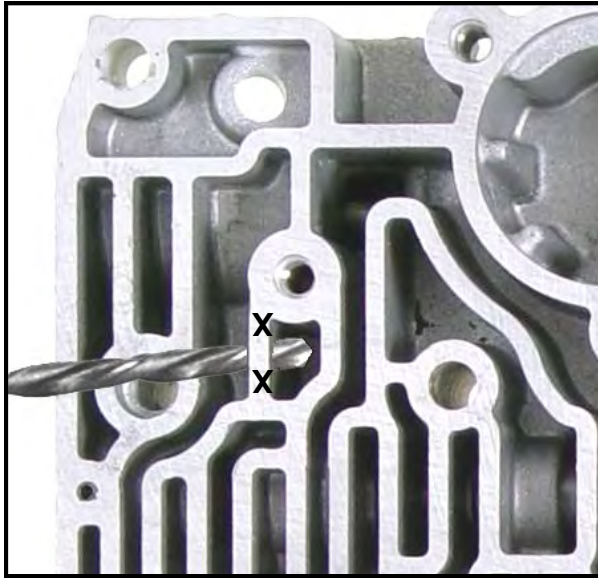

Step 1 Enlarged

### Step 1

Between the "X's" on angle shown, Center punch first then drill through partition with .125 drill. **Then enlarge with .187" drill.** Drill sizes shown on pg 5.

### Step 2

Remove the Accum Valve shown in Step 3. At the white dot drill **down thru the bottom** of the passage with .093 drill. Clean out the drill chips from steps 1 & 2.

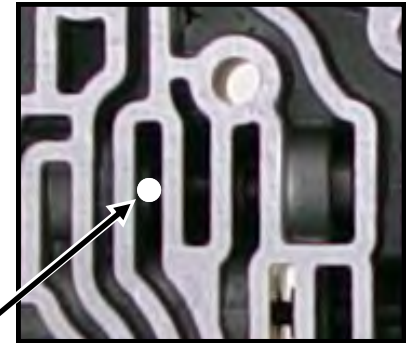

Step 2 Enlarged

**Drills Provided:  
.093-.106-.125-.187**

**Step 2**

New steel plug & O-ring

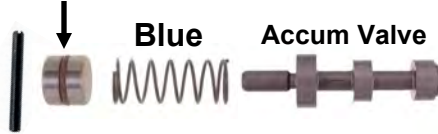

### Step 3

Discard original Accum spring and plug. Install Accum valve, new **BLUE** spring then new plug with O-ring. Install new end plug with threaded end facing out.

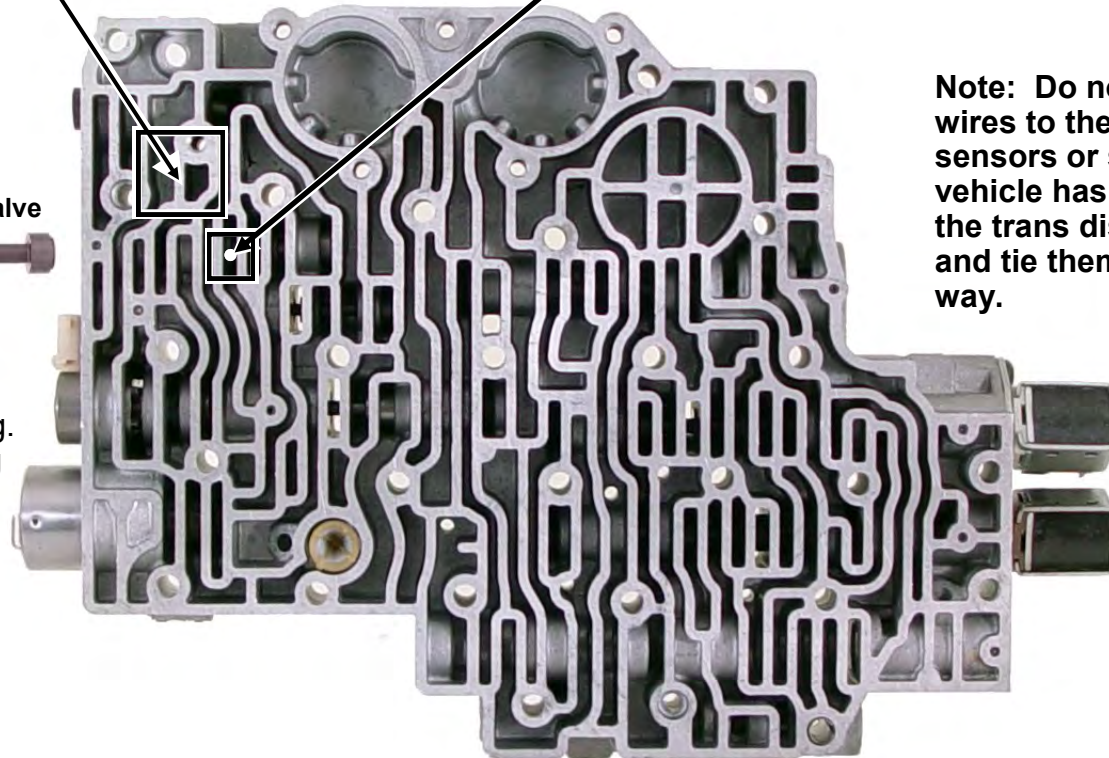

**Note: Do not connect any wires to the valve body sensors or switches. If the vehicle has wires going to the trans disconnect them and tie them up out of the way.**

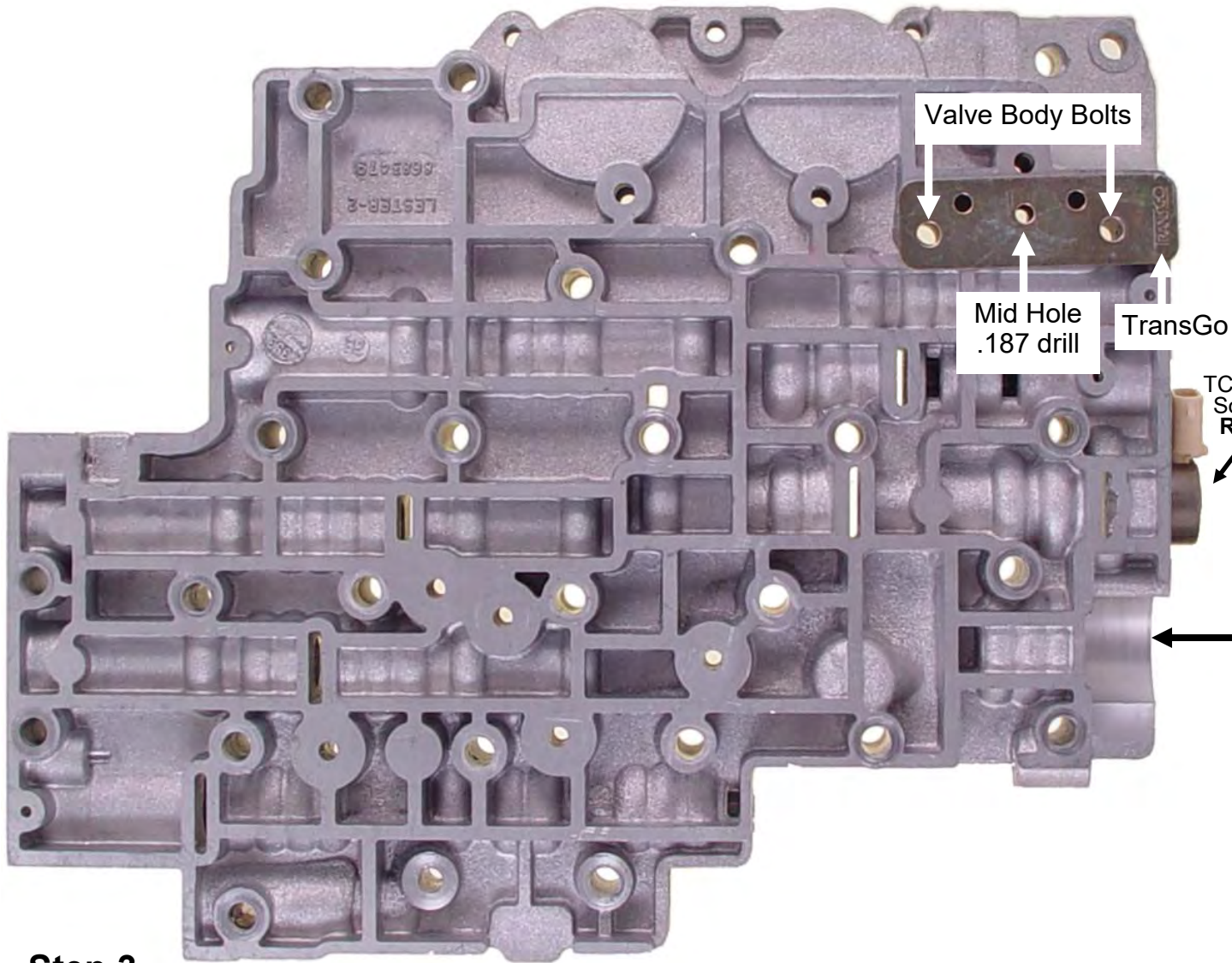

### Step 1

Install relief assembly **cover** with two valve body bolts and the nuts furnished, finger tight. With .187 drill in Mid hole thru the valve body casting. Clean drill chips on both sides of VB when done.

View from Other side when finished.

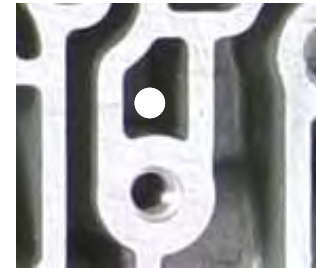

### Step 2

Remove Pressure Control Solenoid and Bracket.



### Step 3

Prepare **relief valve assembly** for installation in step 2 page 8. Install **YELLOW** spring on stem end of valve. Push stem end of valve up thru cover while a buddy installs "E" clip. Use patience when assembling Relief assembly, small parts like to fly across the shop.

### Relief Assembly

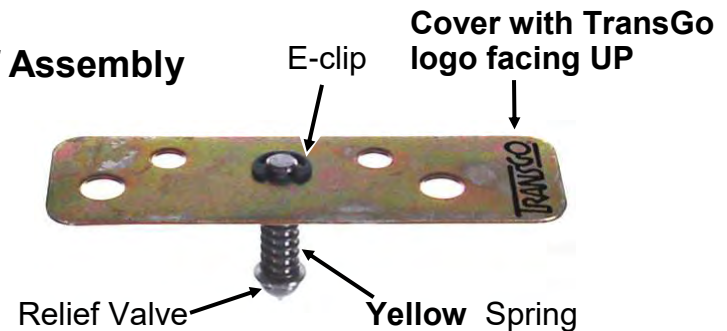

## Step 1

Remove check ball sleeve, 3-4 shift Valve & Spring.  
**Perform Step 1A next, then continue with Step 1.**  
Discard 3-4 Shift Valve Spring, Re-install 3-4 shift Valve.  
Place **PLAIN** Spring into 3-4 shift Valve bore between 3-4 shift Valve & Check Ball Sleeve.

## Step 1A

With 3-4 valve removed drill .093 through the VB at white dot.

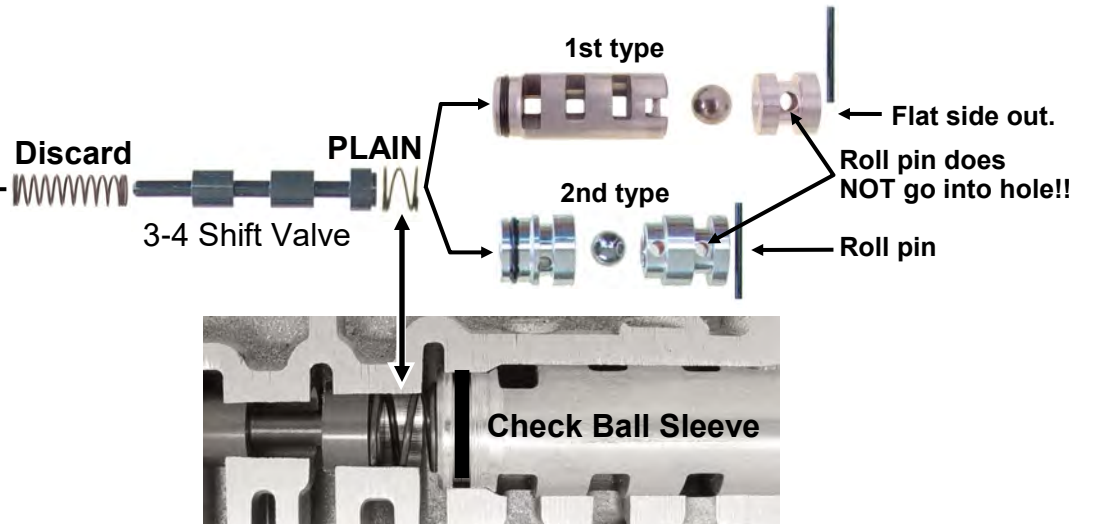
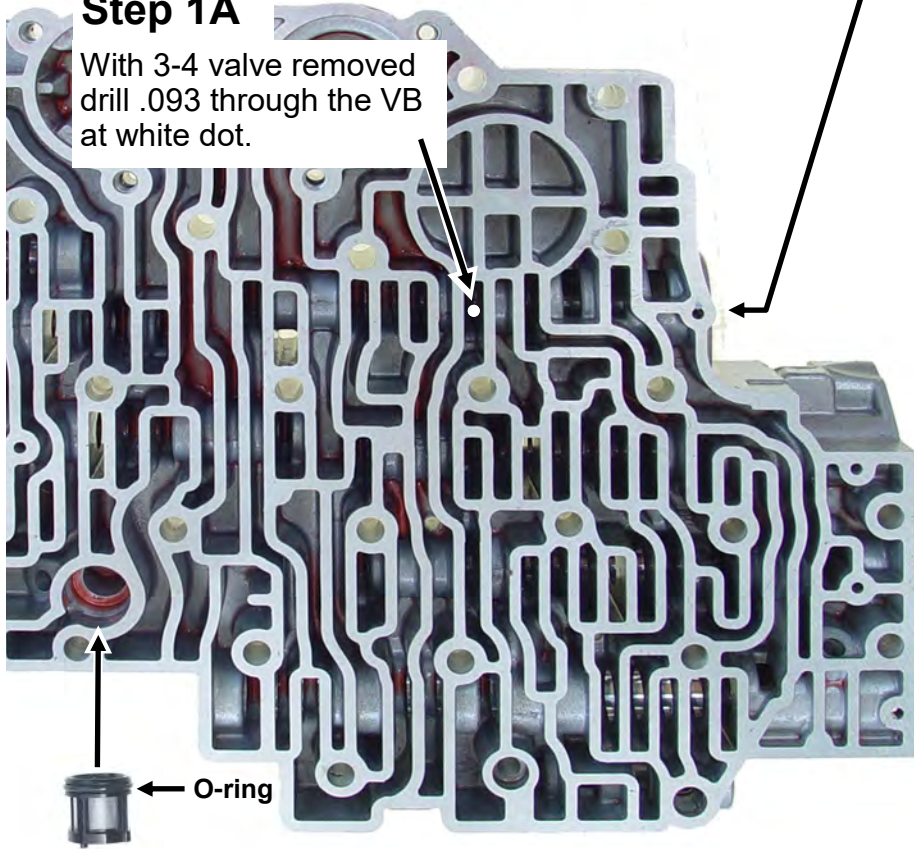

**Step 2** Discard OE 2-3 shift Valve Spring. Install new **RED** spring on roll pin end of valve. **Discard both shift Solenoids.**



**Step 3** Install new 1-2 shift valve end plug & retainer bracket after roll pin.



**Step 4** Install Tapered plug with o-ring, Filter, Orange Spring & new end plug. If end plug roll pin will not line up with pin hole grind 1/16 off filter.

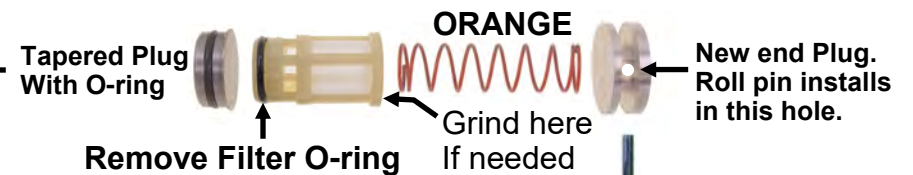

# Separator Plate Hole sizes

**Step 1** Discard original separator plate, drill holes in new plate.

Holes ABC are shift firmness selection:  
ABC: Comfort = .076 Firmer = .093  
AB: Off Road & Hot street = .125  
AB: With high stall converter = .125  
Hot street & High stall make "C" .106

## Drills Provided

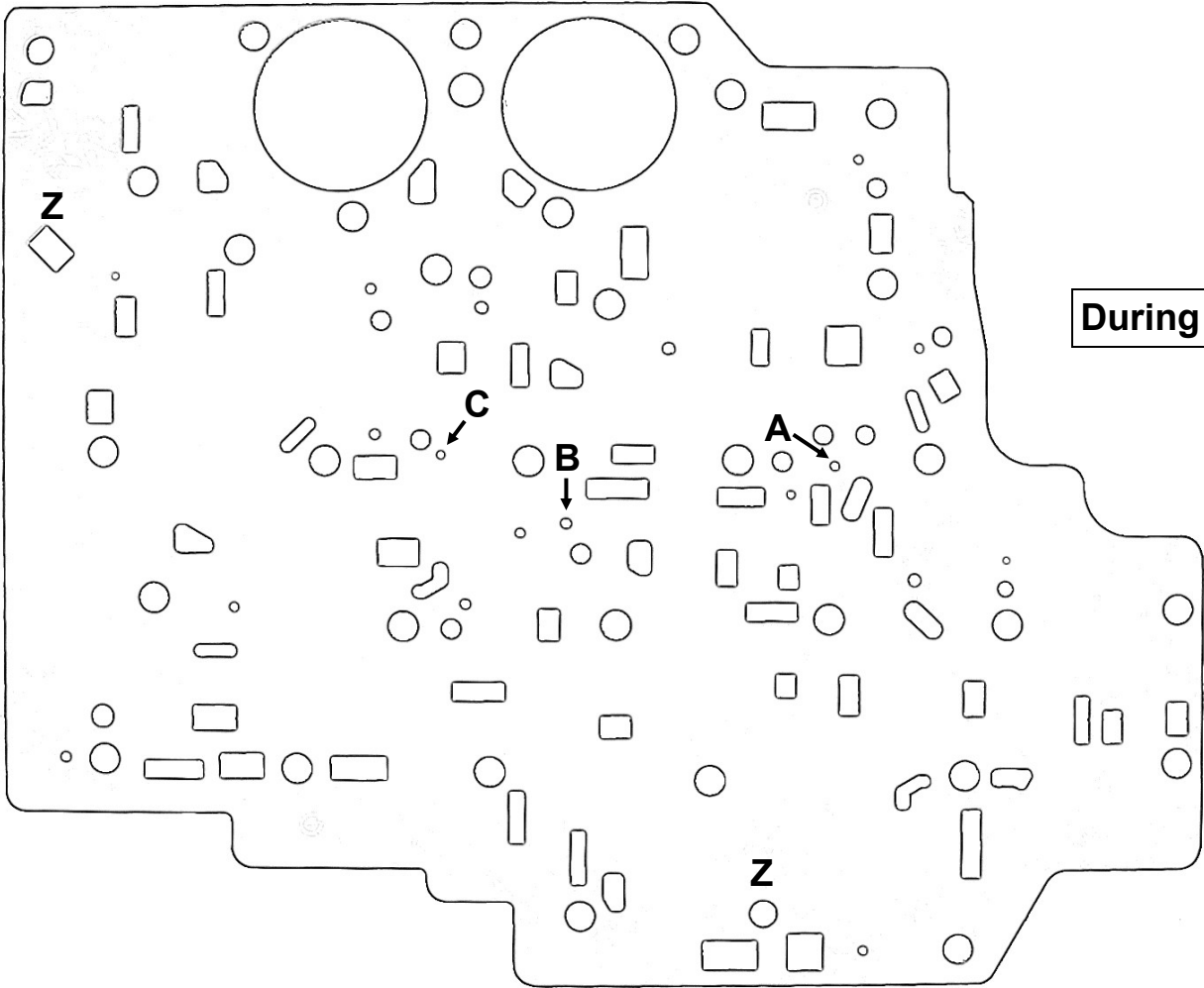

**During assembly install "Z" bolts first.**

## Step 1 Valve Body Assembly

**Note:** The only changes you are making on this page is replacing the 3rd Accum spring. The rest of the steps are for re-assembly purposes.

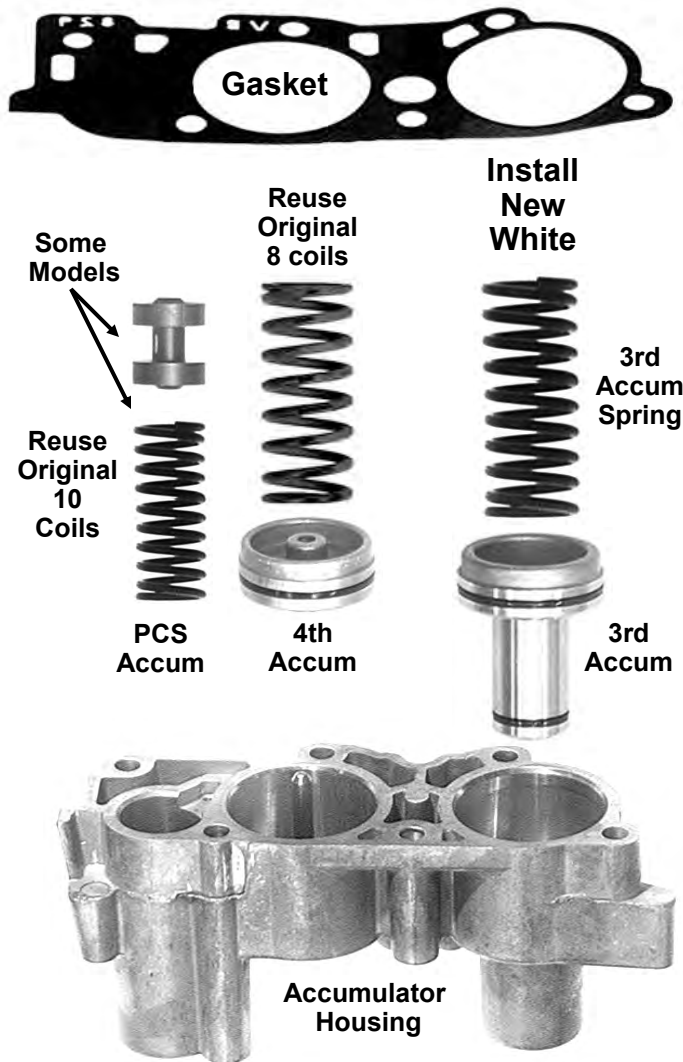

- Discard Original 3rd Accum spring. Install **NEW WHITE** spring.
- Install gasket onto accumulator housing.
- Install **TransGo®** full size gasket and the separator plate onto the valve body. Align the plate and gasket by inserting bolts in holes "Z".
- Install the accumulator housing and tighten the bolts.
- Pull out the "Z" bolts. Put a small amount of oil on the plate and place the Case gasket on the plate and align it carefully at the "Z" holes.
- Place a small amount of assembly gel on the holes for the check balls and place seven 1/4" balls on the holes.

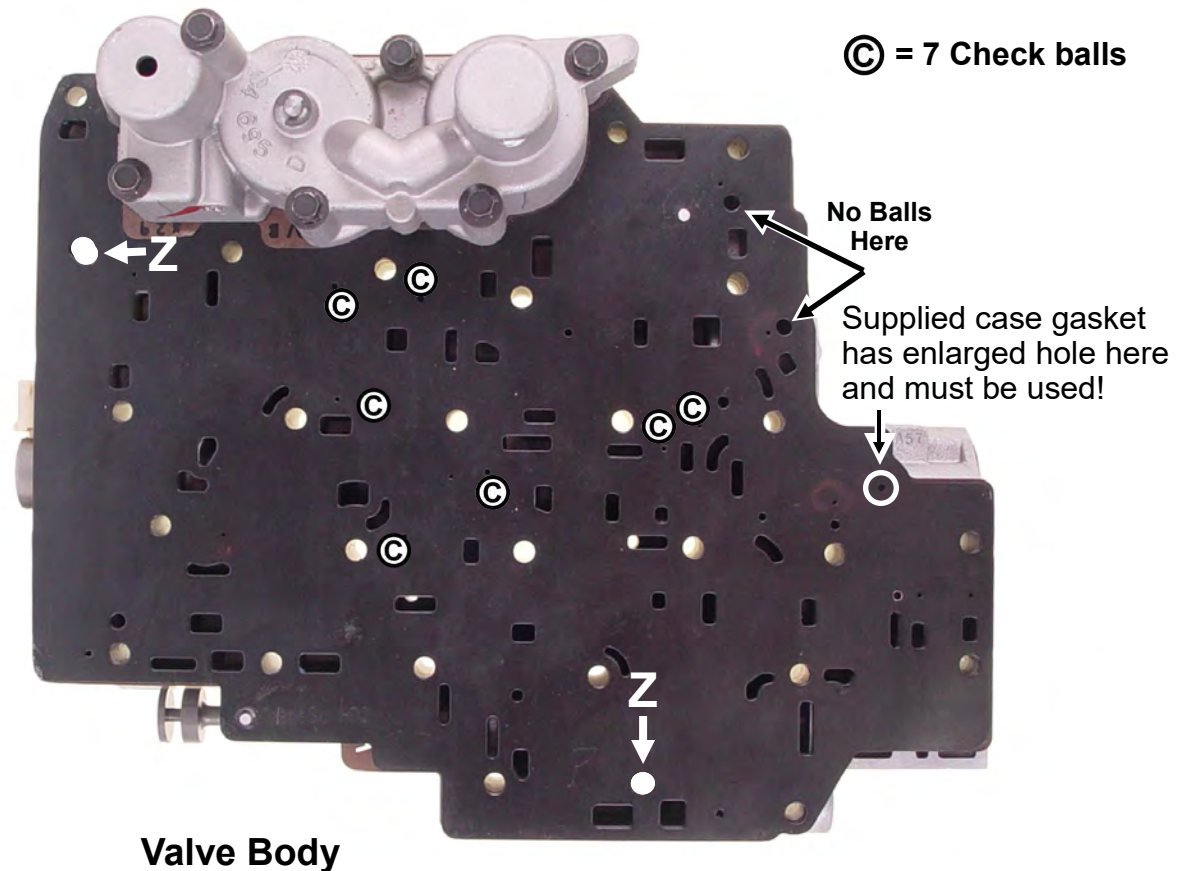

During assembly install "Z" alignment bolts first.



## Step 1

Install & tighten "Z" bolts first. **Re-install TFP switch assembly** (make sure o-rings are in place) and install remaining bolts & tighten.

## Step 2

After tightening all the bolts remove two bolts and install the relief assembly. Discard the dip stick stop bracket if equipped.

When bolts are tight, Gently hit relief valve with small hammer & 1/4" punch 2-3 times to seat it.

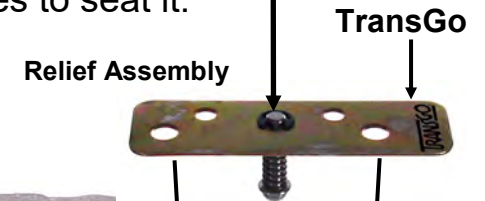

**Bolt torque is 95 -100 Inch Lbs.**

TFP Switch Assy.

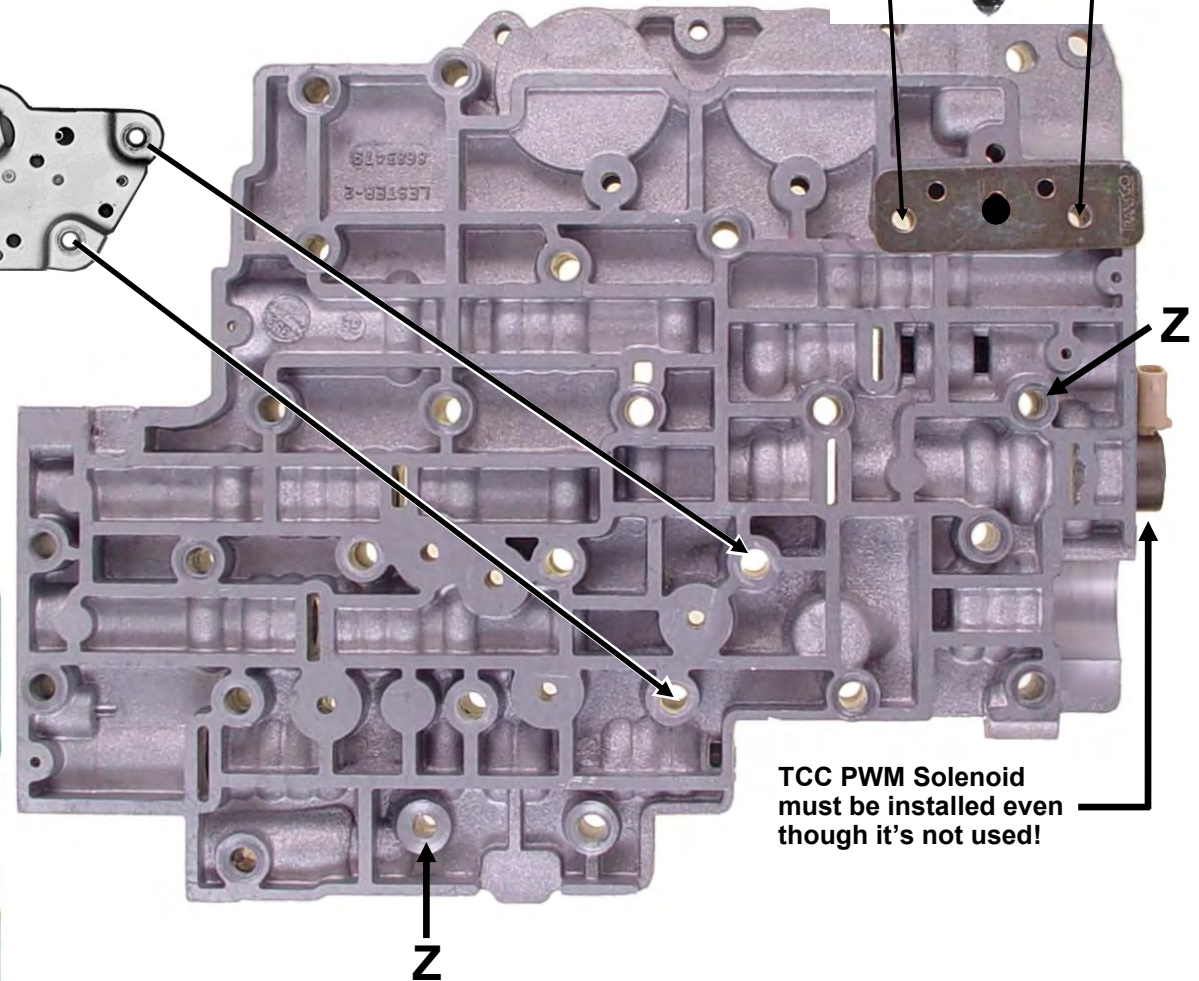
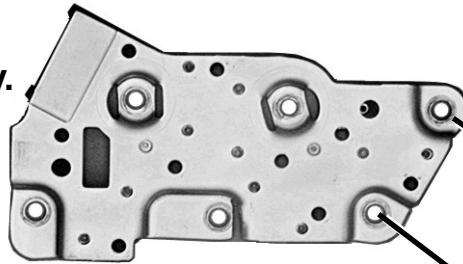

***You're almost done!***  
Install Modulator system in separate package.





## Internal Upgrades—If Trans is Apart.

**Step 1** Carefully pry the lower retainer out of the springs. Then with side cutters grab each spring up close to upper retainer and twist and pull at the same time to remove the springs. Install the springs furnished into the old retainers.

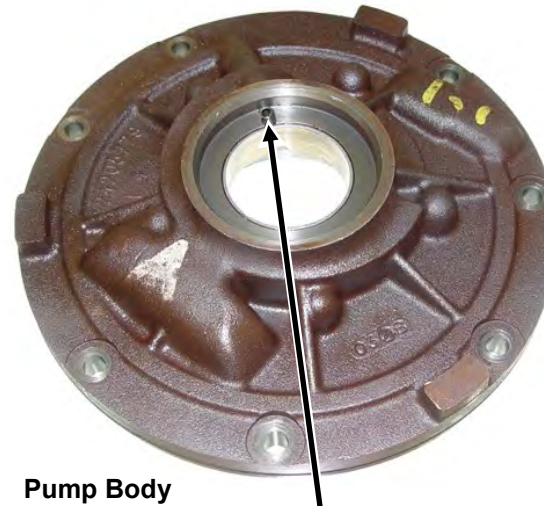
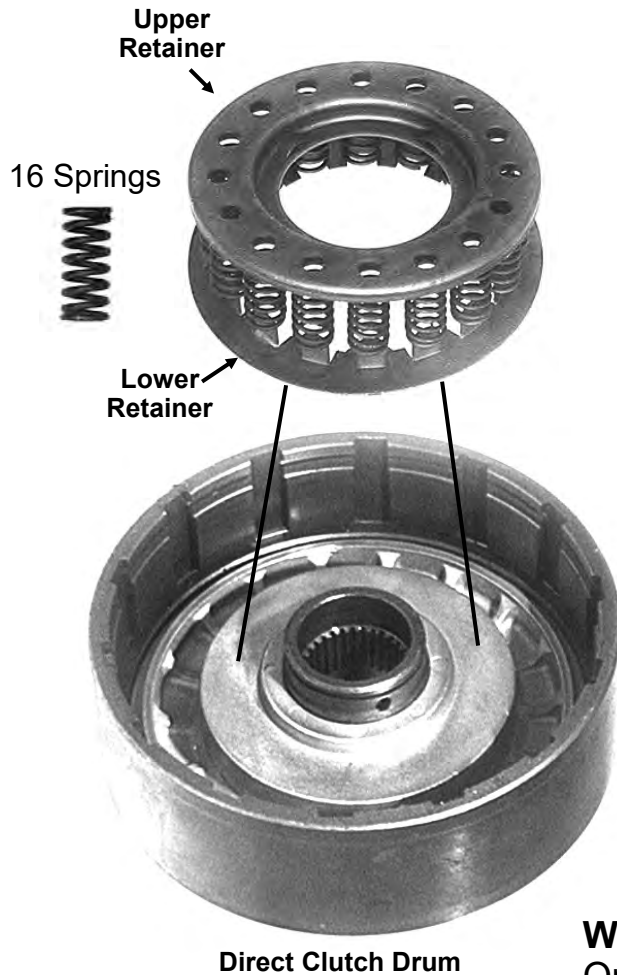

**Step 3** To prevent front seal blowout, Enlarge this hole 1/4" to 9/32".

**When using a NON-lockup converter:**  
Order TransGo® P/N 48-CCV to provide corrected oil flow into the converter. Keeps converter full for better cooling.

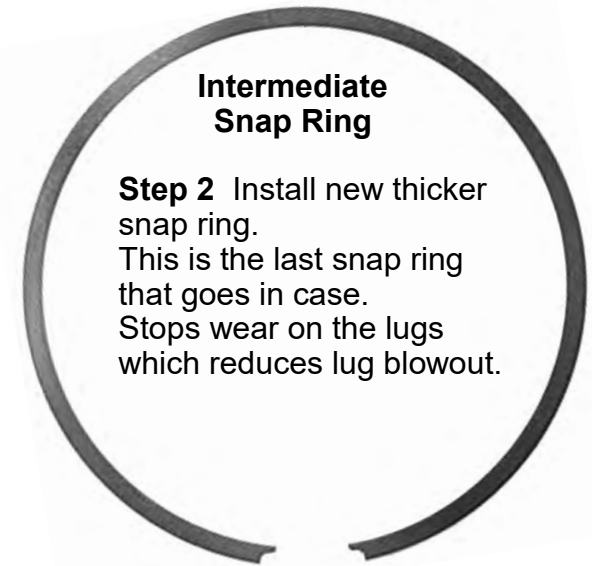

**Step 2** Install new thicker snap ring. This is the last snap ring that goes in case. Stops wear on the lugs which reduces lug blowout.

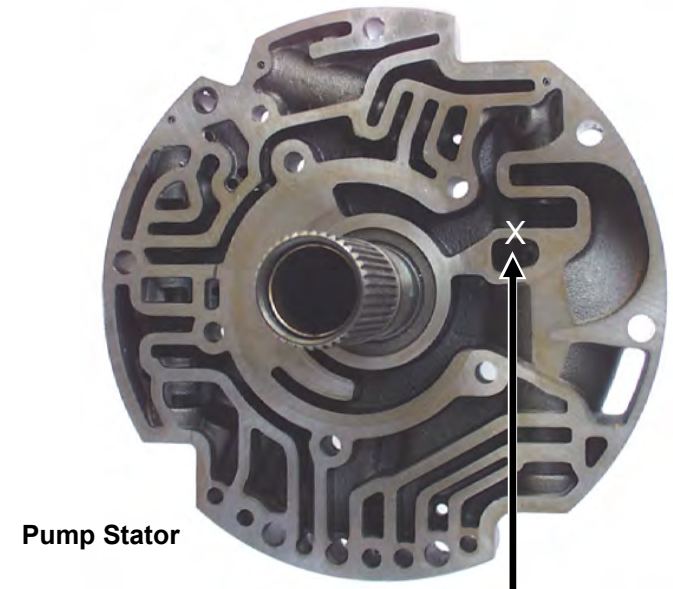

**Step 4** Under "X" drill a 3/64 (.042-.055) hole thru side of wall in direction of arrow.

# Recommended

## Add-on Parts for High Temp Applications and Hot-Rods!

(Install while trans is out of the car for repair/upgrade or overhaul)

### 4L80E-HTRK

#### Hi-Temp Ring & Endplay Upgrade

##### Corrects/Prevents/Reduces

No Lockup and 4th hot—Codes 68—39—85  
Hard shifts and no 4th—Direct Clutch Slippage  
Prevents Metal Particles by Separating Shafts  
Hot Idle Forward Clutch Slip, Aborts LU & 4th.  
Reverse Delay—Bindup in reverse when hot.



### 48-CCV

#### Converts Lock-up Pump to use with Non-Lockup Converter.

For converters **WITHOUT** a converter clutch only!

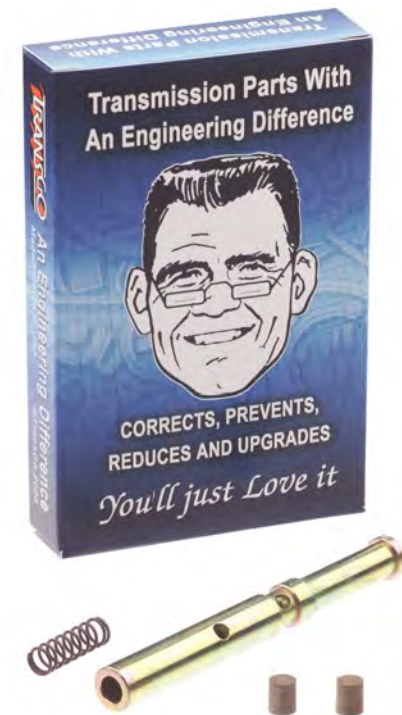

# 4L80E: Vacuum System Installation

*Does not fit diesel*

**IMPORTANT:** This kit is for Hot rod transplants and show off trucks. It should not be installed in trucks for commercial use or towing.

**Step 1** Drill 11/32" hole at black dot. Make sure hole will be positioned in front of bolt boss as shown in picture. Tap the hole, from this side with 1/8" NP. Install fitting into case with sealer.



**Step 2** Install PURPLE pressure regulator spring. You must use PURPLE spring when installing vacuum modulator!

No Lockup or 4th gear when hot with a 68, 39 or 85 code is a common complaint.

Most often the cause is leaking factory type rings that don't like getting hot.

For a lasting **FIX** order **4L80E-HTRK**, a Hi-Temp, Low Shrink ring kit.

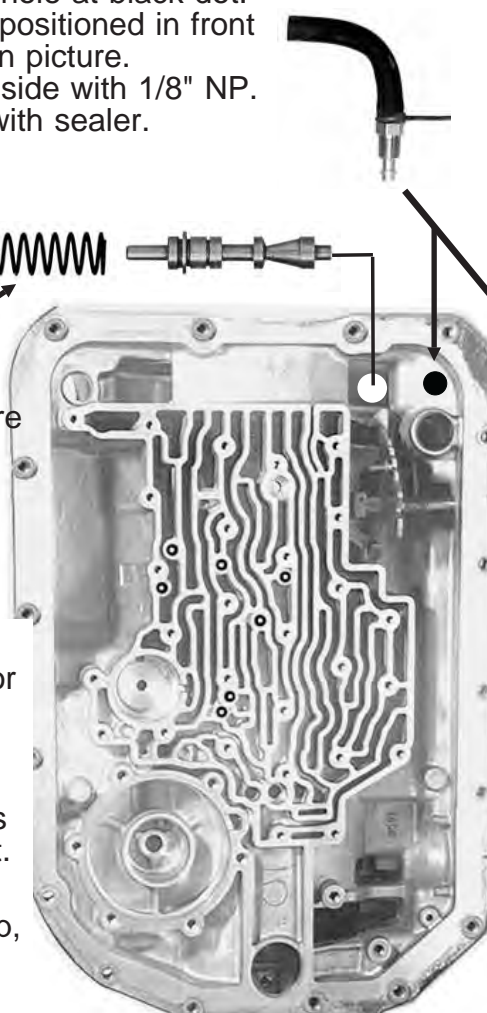

**Step 3** Adjust Pin length: For normal use, shorten the pin to 1.325. If shifts are then too firm, make pin shorter, but do not use a pin shorter than 1.285. Grind as necessary. Use Pin length 1.365 for Hi stall converter use.

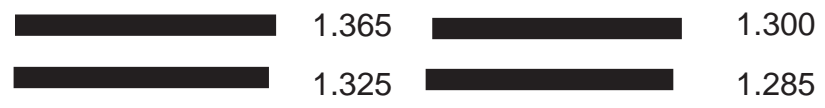

**Step 4** Install the bushing, valve, pin and modulator. Then install long plain spring inside hose and two Zip ties.

**Step 5** Remove two bolts and install the bracket loosely. Push the modulator and the bracket inboard and tighten bolts.

**Step 6** If trans has functional electrical system discard Pressure Control Solenoid and install included resistor.

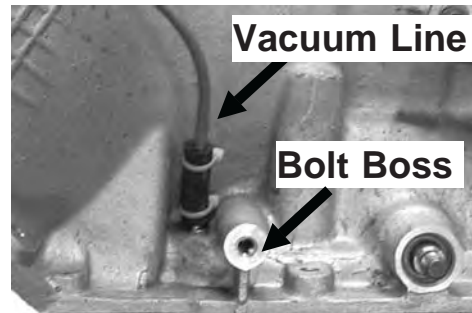

Drill 11/32 hole to position vacuum fitting and line in front of bolt boss as shown!

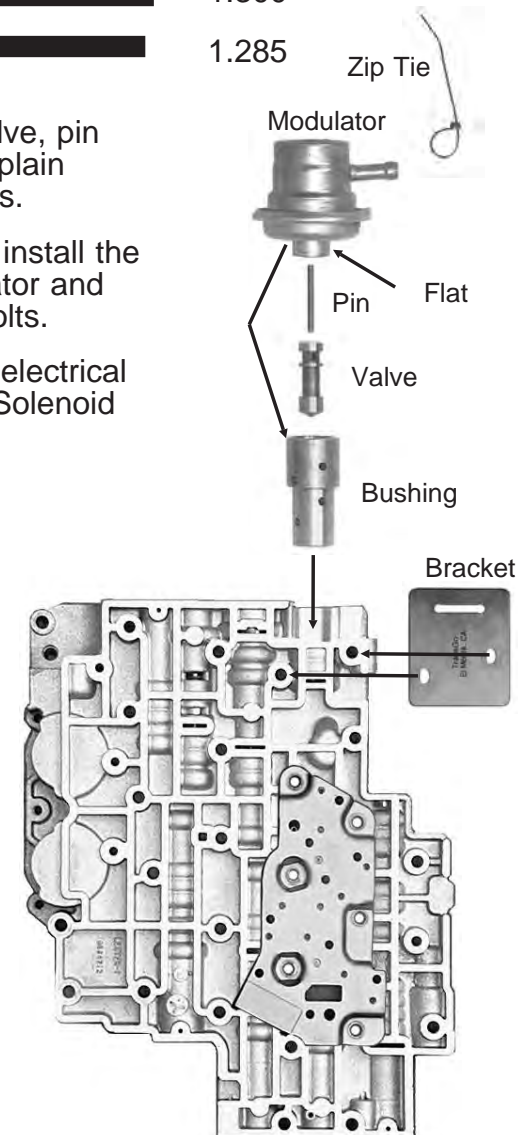

# Installing Vacuum Line

"If the engine is supercharged or turbo'd you'll need a pressure bypass valve in the vacuum tube to prevent high pressure trans damage."

Order TransGo® P/N: VBP-Vac

**Step 1** Using 3/16 Brake line (not provided), route brake line down to modulator case fitting. Use enough line to comfortably reach within 2" of both the vacuum brake booster Tee location (Step 2) and the case vacuum fitting. After determining correct length that will allow you to secure the line and reach both fittings, cut the brake line and swedge both ends to prevent vacuum hoses from slipping off. Secure lines and hoses with Zip-ties.

## Step 3

Install a short piece of Vacuum hose between case fitting and brake line. Make sure rubber vacuum line is as straight as possible to prevent it from becoming kinked. Zip-tie the hose to the line and fitting as shown.



*Mr Shift*®

"Thanks for listening!"

Supercharged or Turbo'd engines require bypass here between Tee and 3/16 brake line leading down to trans. Always zip-tie lines to prevent them from slipping off.

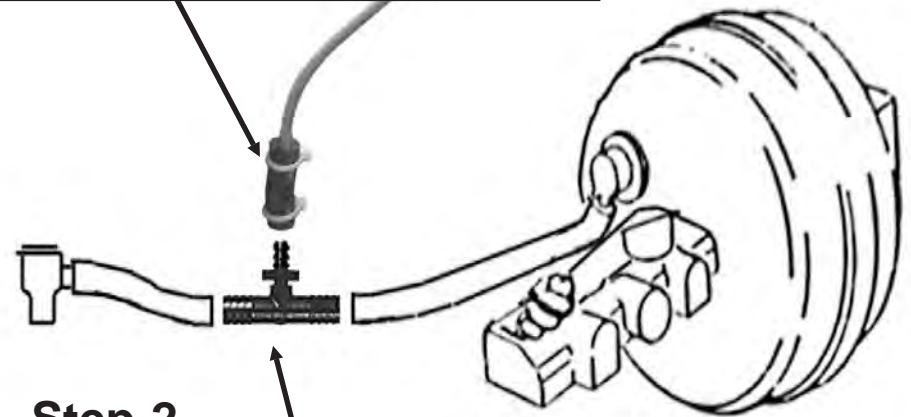

## Step 2

Cut power brake hose and insert tee into hose. Install zip-ties to prevent vacuum leaks.

