



## INSTALLATION INSTRUCTIONS

300 W. Pontiac Way Clovis, CA 93612 toll free: 1-800-595-7016 web: www.stsuspensions.com

50157

### FRONT ANTI-SWAYBAR

1992-1995 HONDA CIVIC, 1993-1997 HONDA DEL SOL, 1994-1999 ACURA INTEGRA

**Thank you for being selective enough to choose our high quality SUSPENSION TECHNIQUES PRODUCT. We have spent many hours developing out line of products so that you will receive maximum performance with minimum difficulty during installation.**

- Note: Confirm that all of the hardware listed in the parts list is in the kit. **Do not** begin installation if any part is missing. Read the instructions thoroughly before beginning this installation.
- Warning:** **DO NOT** work under a vehicle supported by only a jack. Place support stands securely under the vehicle in the manufacturer's specified locations unless otherwise instructed.
- Warning:** **DO NOT** drive vehicle until all work has been completed and checked. Torque all hardware to values specified.
- Reminder: Proper use of safety equipment and eye/face/hand protection is absolutely necessary when using these tools to perform procedures!
- Note: It is very helpful to have an assistant available during installation.

#### RECOMMENDED TOOLS:

- Properly rated floor jack, support stands, and wheel chocks
- Combination wrench set
- Ratcheting socket wrench and socket sets
- Safety Glasses

#### KIT INSTALLATION

1. Open the hardware kit and remove all of the contents. Refer to the part list (Page 3) to verify that all parts are present.
2. Park the vehicle on a smooth, level concrete or seasoned asphalt surface and activate the parking brake. Block the REAR wheels of the vehicle with appropriate wheel chocks; making sure the vehicle's transmission is in 1<sup>st</sup> gear (manual) or "Park" (automatic).
3. Using a properly rated floor jack, lift the front wheels of the vehicle off the ground. Place support stands, rated for the vehicle's weight, and in the factory specified locations. Refer to the vehicle Owner's Manual. Prior to lowering the vehicle onto the stands, make sure the supports will securely contact the chassis.
4. It is very important that the vehicle is properly supported during this installation to prevent personal injury and chassis damage! Make sure that the supports stands are properly placed prior to performing the following procedures. We **DO NOT RECOMMEND** using wheel ramps while performing this installation.
5. Slowly lower the vehicle onto the stands and, before placing the vehicle's entire weight on them, again check that they properly and securely contact the chassis as described above. Check for possible interference with any lines, wires, cables, or other easily damaged components.

6. **CAUTION: EXHAUST MAY BE EXTREMELY HOT. ALLOW THE CAR TO COOL BEFORE CONTINUING INSTALLATION.**
7. Loosen and remove the two bolts holding the exhaust manifold to the front of the catalytic converter. (NOTE: The O2 sensor wire must be unplugged to allow clearance, and prevent damage to the harness. ) Pull the catalytic converter off the exhaust manifold and allow the converter to droop. Remove the shift stabilizer bar from the rear of the transmission and the shift linkage bar from the base of the shift lever. Allow these to droop as well.
8. Remove the end links from the ends of the original equipment Anti-Sway Bar. Remove the bushing brackets as well. Note the position of the Anti-Sway Bar in the vehicle to ease in the installation of your new Suspension Techniques Anti-Sway Bar. Remove the original equipment Anti-Sway Bar from the vehicle.
9. Thoroughly lubricate the **inside** of your new urethane bushings using the lubricant provided. Place the bushings on the new Anti-Sway Bar. Refer to the original equipment Anti-Sway Bar as to the proper bushing location.
10. Position your new Suspension Techniques Anti-Sway Bar on the vehicle in the original equipment location and loosely assemble and mount the new end links to the Anti-Sway Bar and control arms, (see diagram) but, **do not** completely tighten the end links yet.
11. Thread the threaded spacer sleeves onto the original studs and tighten (**see diagram**). Put the spacer blocks in place over the spacer sleeves as shown in the diagram. Secure the bushing brackets and bar to the spacer blocks using the hardware supplied. Thread the original bolts with washers into the threaded spacer sleeves and use the long bolts and washers in the other hole of the spacer block as shown in the diagram.
12. Re-connect the shift linkage back to the base of the shift lever and the shift stabilizer bar to the rear of the transmission. Re-connect the catalytic converter up to the exhaust manifold and tighten the nuts to the manufacturer's specification. Reconnect the O2 sensor wire.
13. Assemble the end links as shown in the diagram. Tighten the assembly until the grommets begin to bulge, but **do not** crush them.
14. Check that all components and fasteners have been properly installed, tightened and torqued.
15. Check brake hoses, steering and other components for any possible interference.
16. Lift vehicle and remove support stands. Carefully lower vehicle to ground.
17. Immediately test-drive the vehicle in a remote location so that you can become accustomed to the revised driving characteristics and handling. Be aware that the vehicle will handle substantially different now that it has been modified.
18. Installation is complete. Check all of the hardware and re-torque at intervals for the first 10, 100, 1000 miles.

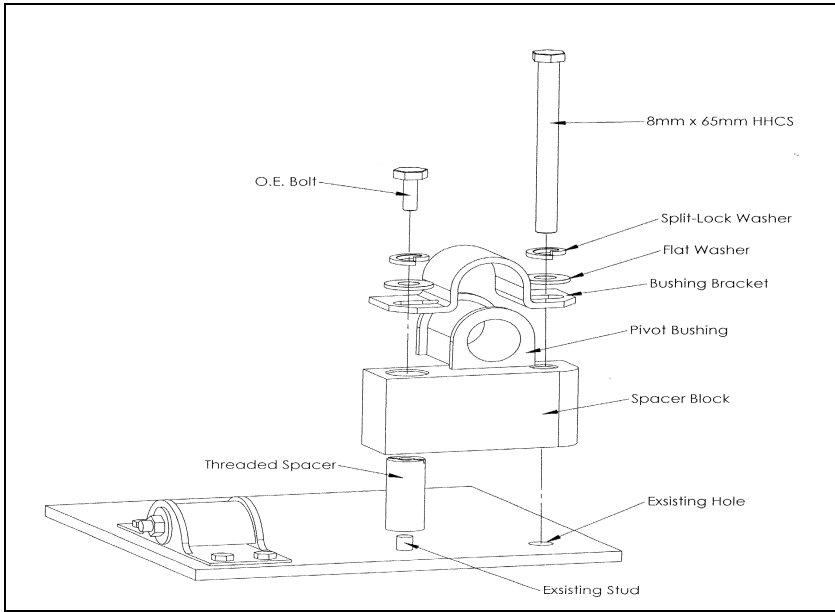
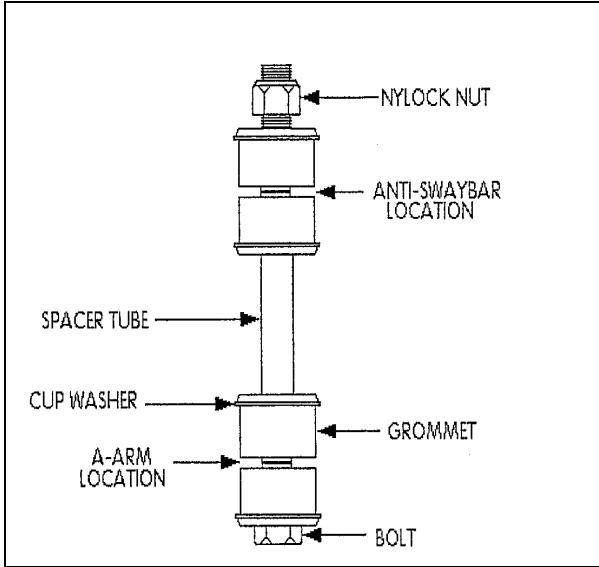

## PARTS LIST FOR ANTI-SWAY BAR KIT

<b>PART No.</b>	<b>DESCRIPTION</b>	<b>QTY.</b>
50157-300	FRONT ANTI-SWAYBAR	1
113005	URETHANE PIVOT BUSHING - 1"	2
113001	URETHANE END LINK GROMMET	8
114030	BUSHING BRACKET	2
110255	3/8" - 16 NYLOCK NUT	2
112504	CUPPED WASHER Small	8
112116	3/8" - 16 x 3 3/4" HHCS	2
112444	3/8" x 1/2" SPACER	2
50157-050	ALUMINIUM SPACER BLOCK	2
50157-025	THREADED SPACER SLEEVE	2
50157-003	8mm - 1.25 x 65mm HHCS	2
112510	5/16" USS FLAT WASHER	4
112512	5/16" SPLIT LOCK WASHER	4
55000-10	GREASE PACK	1