

INSTALLATION INSTRUCTIONS

COOLANT EXPANSION TANK

REMOTE MOUNT, LOTUS 2ZZ-GE





Document: 19-0133
 Support: info@radiumauto.com



WARNINGS:

DO NOT WORK ON THE COOLANT SYSTEM WHEN THE ENGINE IS AT OPERATING TEMPERATURE.
 WAIT UNTIL THE ENGINE HAS COOLED AND THERE IS NO LONGER PRESSURE IN THE SYSTEM.

QUICKLY CLEAN UP ANY COOLANT THAT HAS SPILLED AS IT IS POISONOUS.

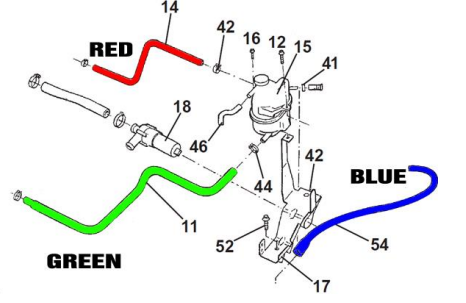
STEP	TOOLS NEEDED	INSTRUCTIONS	PHOTO
1	Metric Allen wrench	Place the included gasket in between the 2 coolant tank halves.	
	Torque wrench	Using a 3mm Allen hex wrench, install the 7 included socket head bolts.	
	Anti-seize	Use anti-seize on the threads to prevent galling.	
		Tighten all bolts evenly until snug in a criss-cross sequence (as shown), then tighten each bolt to 38 in-lbs using a calibrated torque wrench. WARNING: Do not overtighten! NOTE: After the tank is heat cycled, check the gasket for leaks and retorque if needed.	
2		Hand-tighten both elbow fittings in the 1/8" NPT ports. Then add an additional 1.5 to 3 turns until tight. The tapered pipe threads are preimpregnated with Teflon so no addition lubrication is required.	
		In order to install the clear tubing, temporarily clock each fitting, as shown.	
		Verify that the included clear tubing is 81mm (+/-1mm).	
		Push-in and fully insert the tubing into either elbow fitting, as shown.	
3		Bend the tube just enough to get it into the opposing instant tube fitting, as shown. NOTE: the fittings might need to be rotated slightly.	
4	8mm open end wrench	Using an 8mm open end wrench, rotate the elbow fittings so they are in line with one another. NOTE: if not tight enough, the elbow fittings may need to be rotated 360 degrees.	

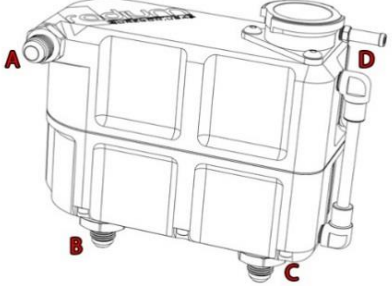
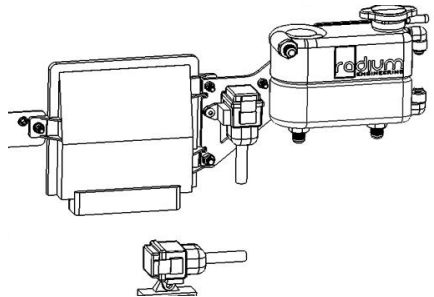
5		Inspect the tubing. If it is not get completely straight, the tube is most likely slightly too long, as shown.	
		To fix, rotate the elbow fittings back as before. Simultaneously push the retaining locks flush to release the tube from the each elbow fitting.	
		Shorten the tube slightly, then reinstall.	
6		Make sure the area shown in the picture is free of dirt and debris before proceeding.	
		Place the included O-ring into the groove around the fill neck opening.	
7	3mm Allen wrench	Place the included fill neck receiver onto the tank, oriented to best fit the application.	
	Thread locker	Apply a medium strength thread locker and install the 3 included socket head bolts using a 3mm Allen hex wrench, as shown. Torque to 48 in-lbs. (5.4Nm).	
8	Lubrication oil	Before installing the 3 included adapter fittings, lubricate the O-rings with light oil.	
	3/4" wrench	Secure the two 10AN ORB to 6AN male fittings into the bottom ports and the 6AN ORB to 6AN male fitting to the side port.	
	1" wrench	NOTE: The tank's internal chambers are divided vertically down the middle for the swirl mechanism, but small passages on the top and bottom allow water to flow throughout the complete tank.	
9	Thread locker	The mounting bracket will be secured to the coolant tank using the 3 inner slotted bolts holes. Apply a medium strength thread-locker to the three M6 bolts. Secure the bracket to the coolant tank using a 4mm Allen hex wrench.	
	4mm Allen wrench		
10		Before uninstalling, note the functions of the colored hoses shown. Red (14): Hot water air-bleed coming out of the cylinder head. Green (11): Coolant returning from the tank to the thermostat housing. Blue (54): Radiator air-bleed and bypass when thermostat is closed.	

11		<p>Swirl Pot Inlet (A): This port is used as for hot incoming water.</p> <p>Drain Back Suction Outlet (B): This port typically routes water back just upstream of the water pump.</p> <p>Air Bleed Inlet (C): This port is commonly used to bleed air from the system. It should connect to the highest point of the engine.</p> <p>Overflow Purge Outlet (D): When the pressure of the coolant system exceeds the cap's rated pressure, hot coolant is released through this barbed fitting. Attach a hose down underneath the vehicle or install an overflow tank that can be used to catch and return the excess coolant.</p>	
	Cutting dikes	<p>If mounting in a 2004-2005 Lotus Elise/Exige, install the coolant tank bracket on the two inboard ECU mounting studs. Mount the inboard most fuse holder between the ECU and the coolant tank, as shown.</p> <p>For the remaining fuse holder, clip the zip tie holding the fuse wiring harness to the firewall and install it in a horizontal position below the ECU on the factory stud.</p> <p>For 2006-2011 Lotus Elise/Exige, mount as described above but exclude rearrangement of fuses.</p>	
13	Coolant	<p>Lotus recommends a 50/50 mix of Havoline XLC Extended Life Coolant.</p> <p>When filling the coolant tank, unscrew the rear air bleed plug (pictured). Note: If filling the entire system, there is also an air bleed plug near the radiator and is accessed under the front right removable panel. Opening these bleed screws alleviates a potential air lock.</p> <p>Fill the system slowly until each bleed location spews coolant.</p>	
14		<p>Fill the coolant system slowly until each bleed location spews coolant. Only fill the tank until the sight tube registers half full. Note: The level will naturally rise as the engine warms up from heat expansion.</p> <p>Start the engine and monitor the digital coolant display on the dash. Note: There will be no coolant reading until the engine heats up. If the temperature continues to climb towards 212F (100C), there is a trapped air bubble(s). This is common in the 2ZZ-GE. An effective remedy is using a coolant re-filler, such as OTC P/N: 75260 (pictured).</p>	