

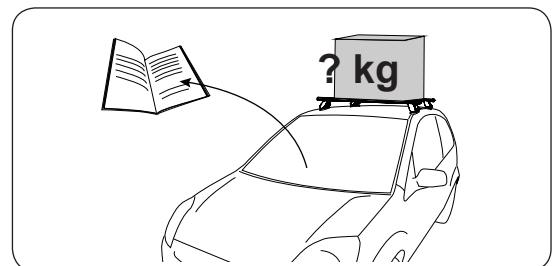

**CONTROLLED**

# RHINO-RACK

## WARNING!

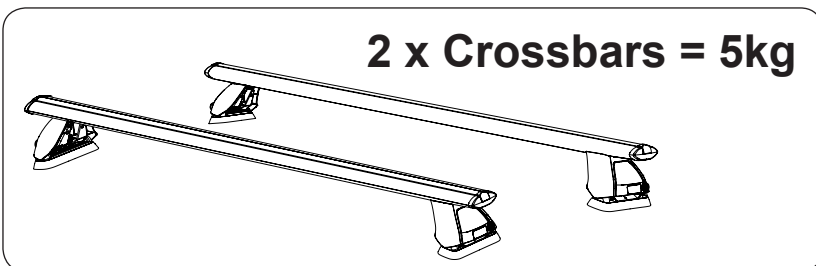
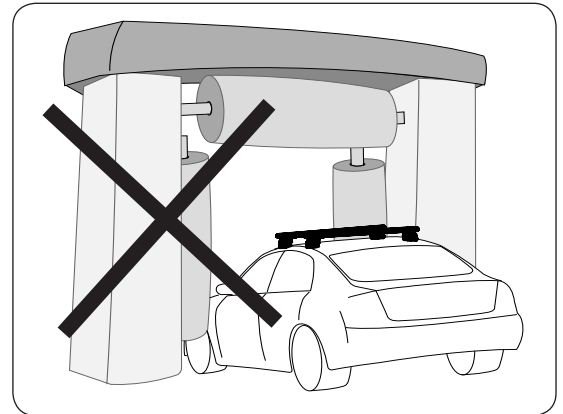
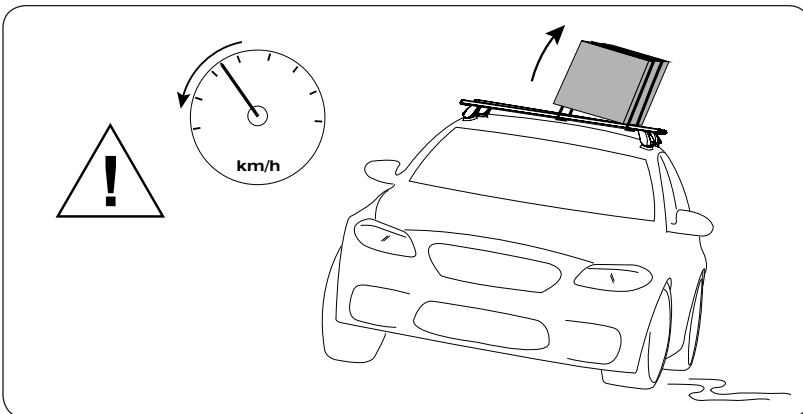
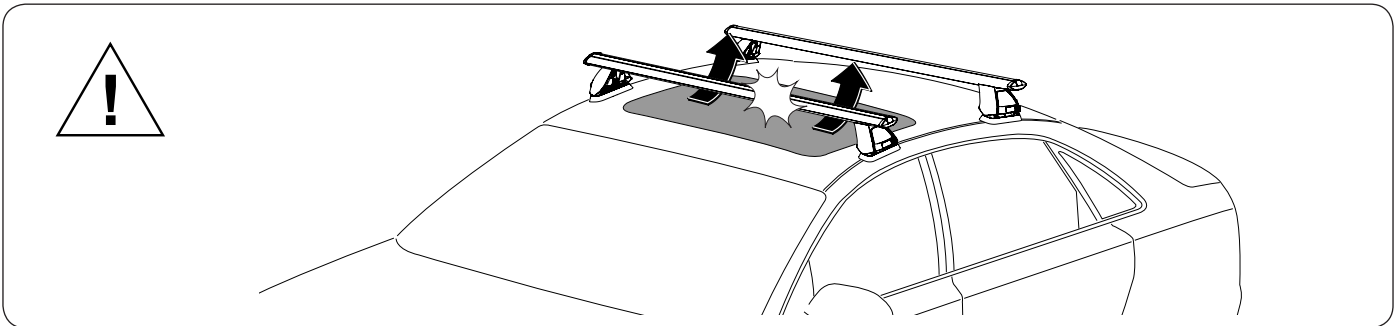
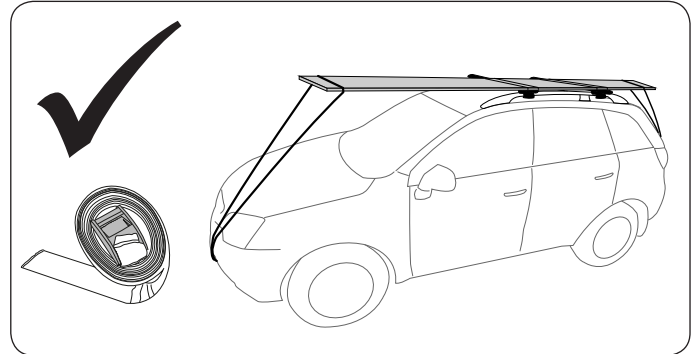
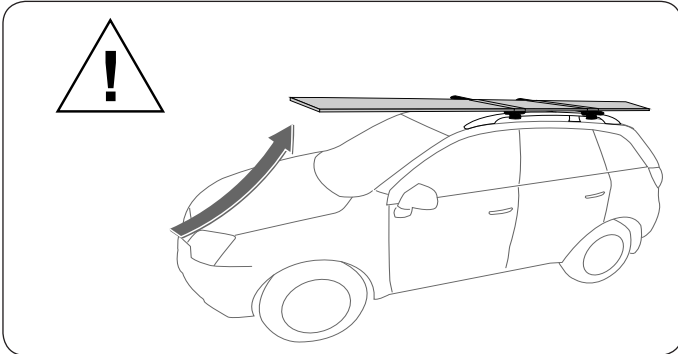

- Please refer to your vehicle manufacturers handbook for maximum roof load capacity.
- Any load transported on Roof Racks must be evenly distributed.
- Do not attempt to fit the roof racks to your vehicle unless you fully read and understand the fitting instructions provided.
- Please direct any questions to the dealer from where the roof racks were purchased.
- Check the contents of kit before commencing fitment and report any discrepancies.



# RHINO-RACK

## Rhino Track Mount - Jeep Wrangler JK MY11 Hardtop

RTC8JWMY11 (2 door)    RTC12JWMY11 (4 door)

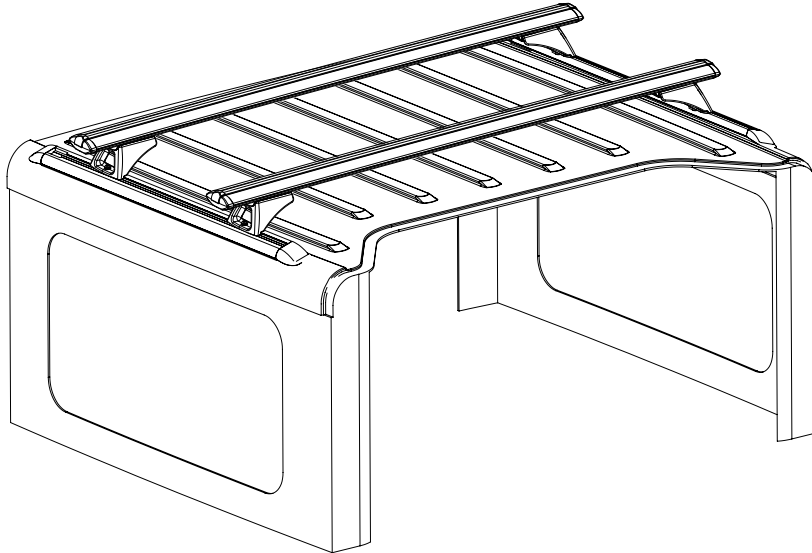

**Hardtop must be removed from vehicle to fit the track system**

**Maximum carrying capacity: 45kg (99lbs)** including weight of the roof racks **5kg (11lbs)**.  
Load must be evenly distributed over the crossbars.

**Use only non-stretch fastening ropes or straps.**

### Recommendations:

All bolt connections must be checked after driving a short distance when you first install your roof racks. Bolt connections should be checked again at regular intervals (once a week is enough, depending on road conditions, usage, loads and distances travelled). You should also check the condition of your roof racks each time they are re-fitted. Always make sure to fasten your load securely. Please also ensure that all loads are evenly distributed and that the centre of gravity is kept as low as possible. Long loads (e.g. canoes and kayaks) must be secured front and rear with non-stretch fastening ropes or straps.

### Roof racks must be removed when putting vehicle through an automatic car wash.

**Caution:** The handling characteristics of the vehicle changes when you transport a load on the roof. For safety reasons we recommend you exercise extreme care when transporting wind-resistant loads. Special consideration must be taken into account when cornering and braking.

### Off-road use:

Maximum permissible load is 45kg (99lbs) on 2 crossbars including weight of the roof racks, 5kg (11lbs). When roof racks are to be used in off-road conditions, please build a safety factor of 1.5 into this load limit. 30kg (66lbs) for off-road use. Although the roof racks are tested and approved to AS1235-2000, off-road conditions can be much more rigorous. However, increasing the number of crossbars does not increase the vehicles maximum permissible roof loading.

### Note for Dealers and Fitters:

It is your responsibility to ensure these fitting instructions are given to the end user or client. Place these instructions in the vehicle's glove box after installation is complete.

Rhino-Rack  
3 Pike Street, Rydalmere,  
NSW 2116, Australia.  
(Ph) (02) 9638 4744  
(Fax) (02) 9638 4822

Document No: R194  
Prepared By: Craig Jones  
Authorised By: Chris Murty

Issue No: 03  
Issue Date: 03/09/2014

These instructions remain the property of Rhino-Rack Australia Pty. Ltd. and may not be used or changed for any other purpose than intended.



# Jeep Wrangler JK MY11 hardtop

## Parts List

Item	Component Name	Qty 2d	Qty 4d	Part No.
1	End Cap (FL/RR)	2	2	M526
2	End Cap (FR/RL)	2	2	M525
3	Rhino Track 800mm	2	0	A256-800
4	Rhino Track 1200mm	0	2	A256-1200
4	M6 x 50mm Square head bolt	8	12	B143
5	Knob & M6 nyloc nut	8	12	M175
6	6mm x 3mm O-ring	4	8	C347
7	Fitting instruction	1	1	R194

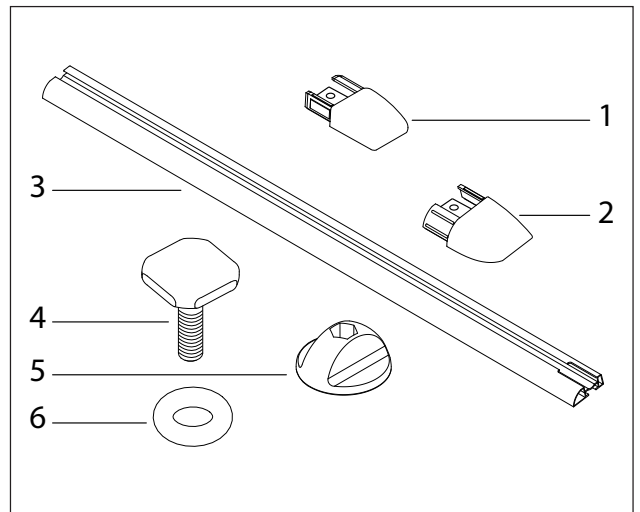

### Tools required:

Masking tape.

6.5mm drill bit.

Tape measure.

T40 Torx key.

Marking pen.

Power or battery drill.

**1**

### Remove hardtop.

Refer to vehicle manufacturer's manual for removing the hardtop.

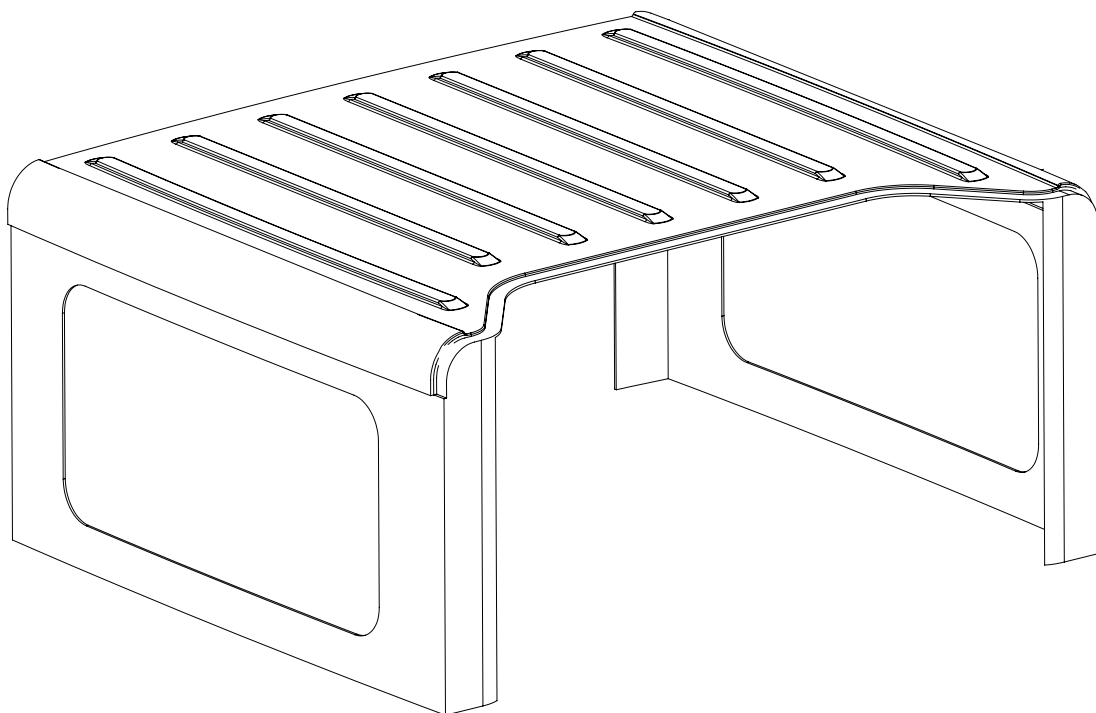



# Jeep Wrangler JK MY11 hardtop

2

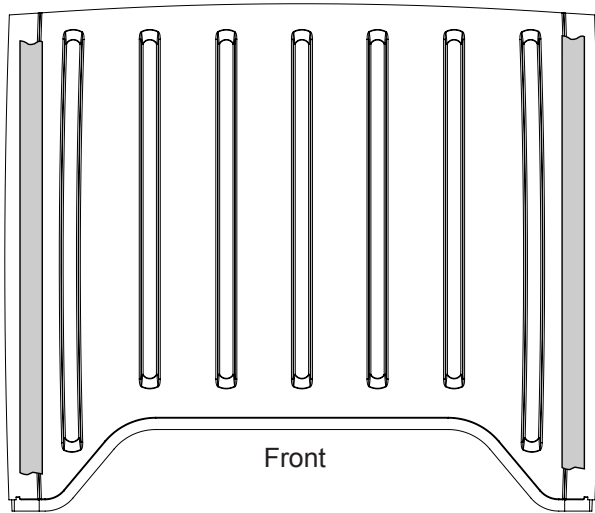

**Masking tape.**  
Apply masking tape to curved outer surface of hardtop.

3

## 2dr hardtop

### Track positioning.

Edge of track can be used to mark a straight line.

- a. Measure **24mm** from tangent of hardtop radius front and rear. Mark drilling centreline.
- b. Front of track. Measure **160mm** from front where the rubber seal meets.

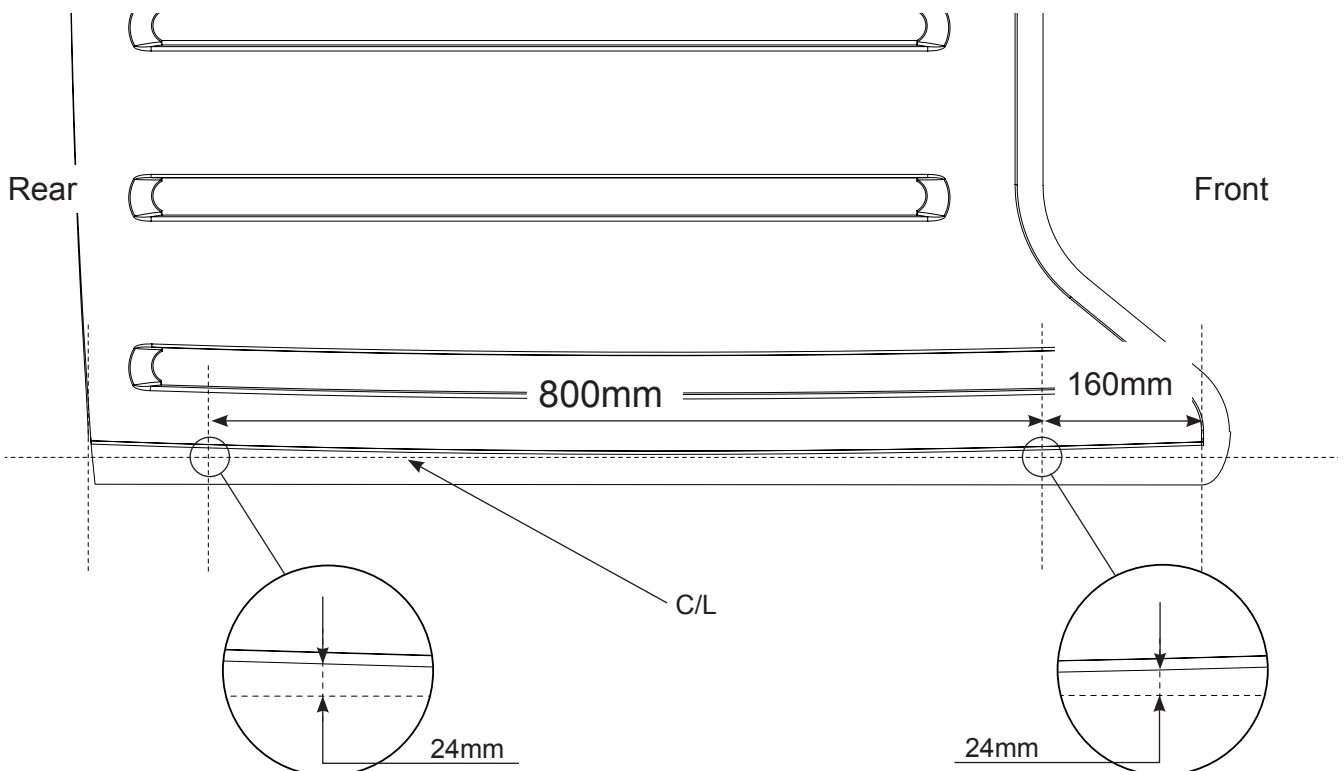
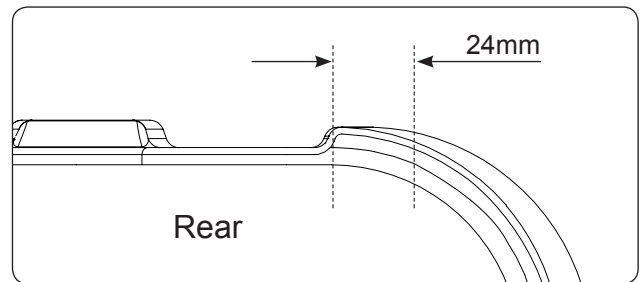
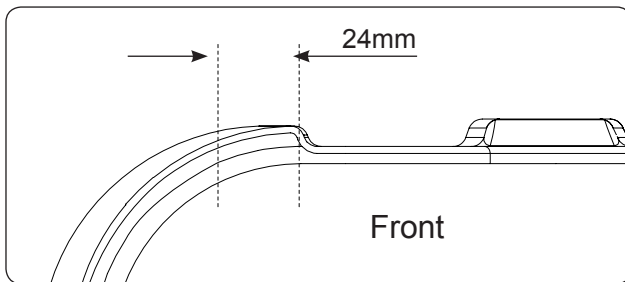



# Jeep Wrangler JK MY11 hardtop

## 4 2dr track mounting holes.

Drill 4 holes through hardtop at measurements shown.

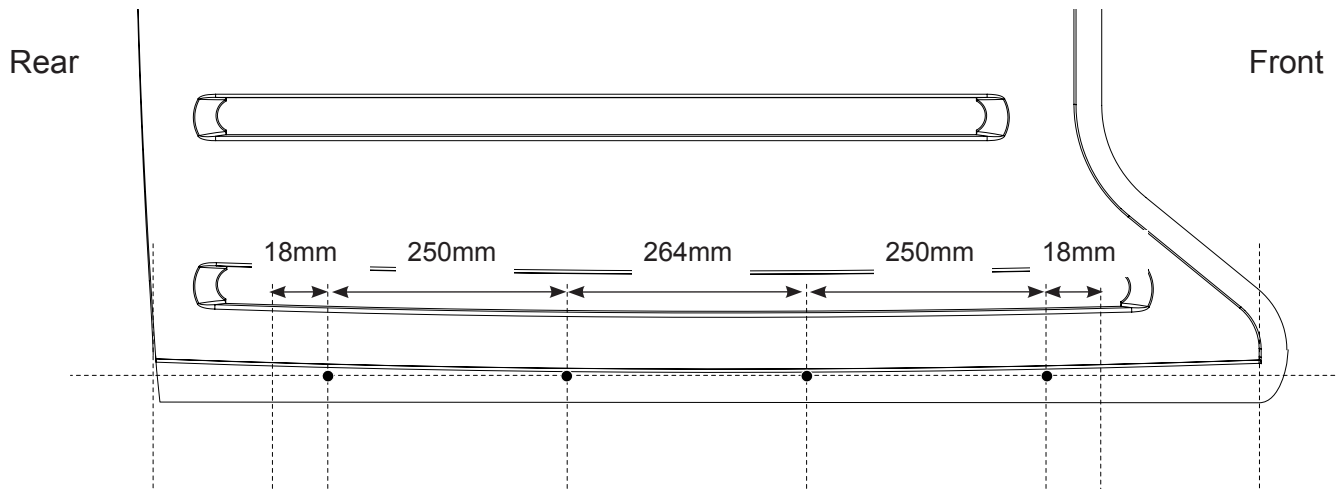

## 5 4dr hardtop

### Track positioning.

Edge of track can be used to mark a straight line.

- Measure **16mm** from tangent of hardtop radius at front, front edge of track hangs over on inside a little. Measure **26mm** from tangent of hardtop radius at rear. Mark drilling centreline.
- Front of track. Measure **140mm** from front where the rubber seal meets.

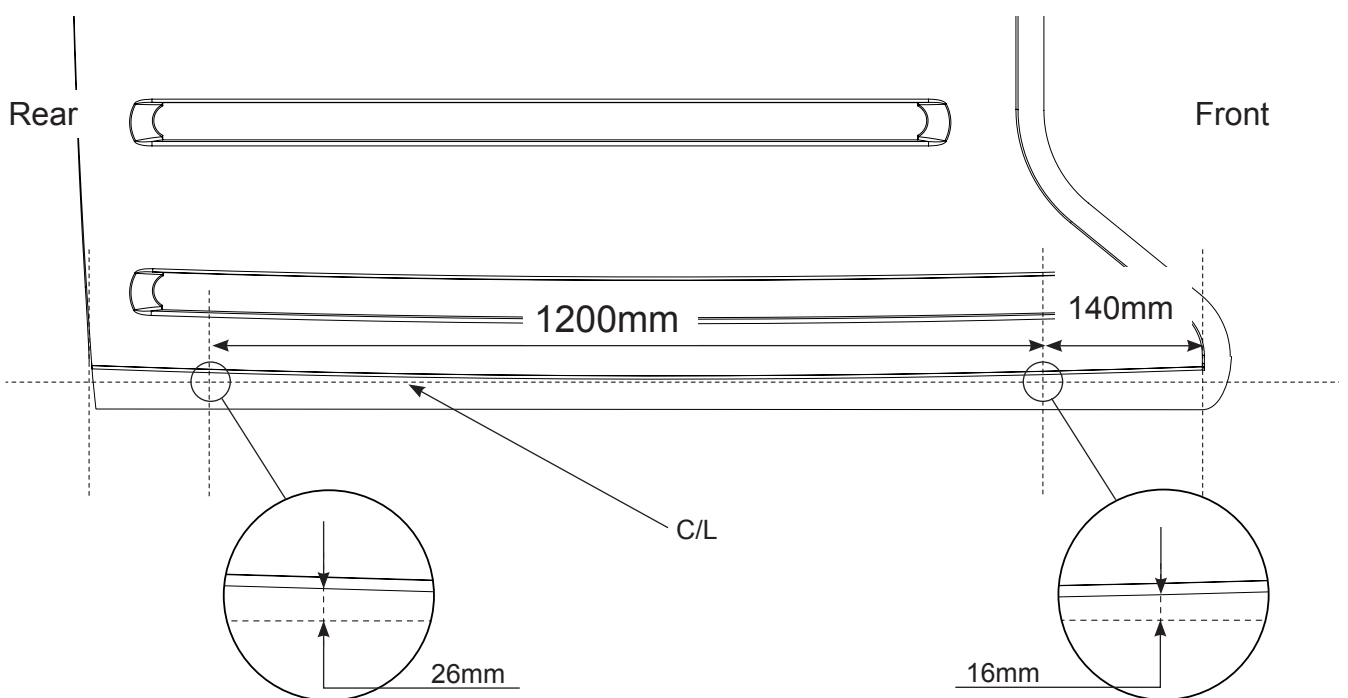
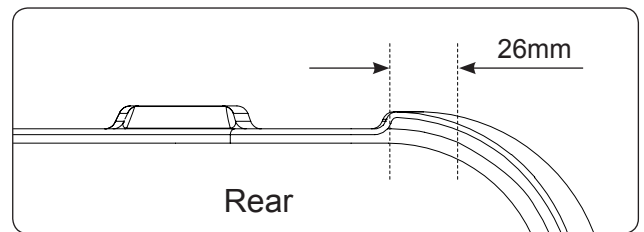
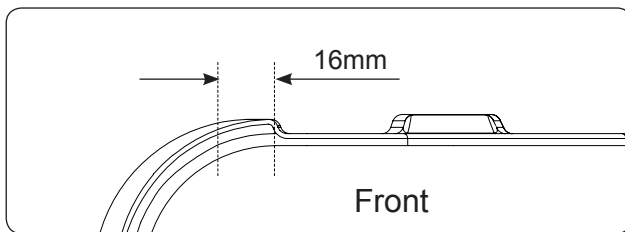



## Jeep Wrangler JK MY11 hardtop

### 6 4dr track mounting holes.

Drill 6 holes through hardtop at measurements shown.

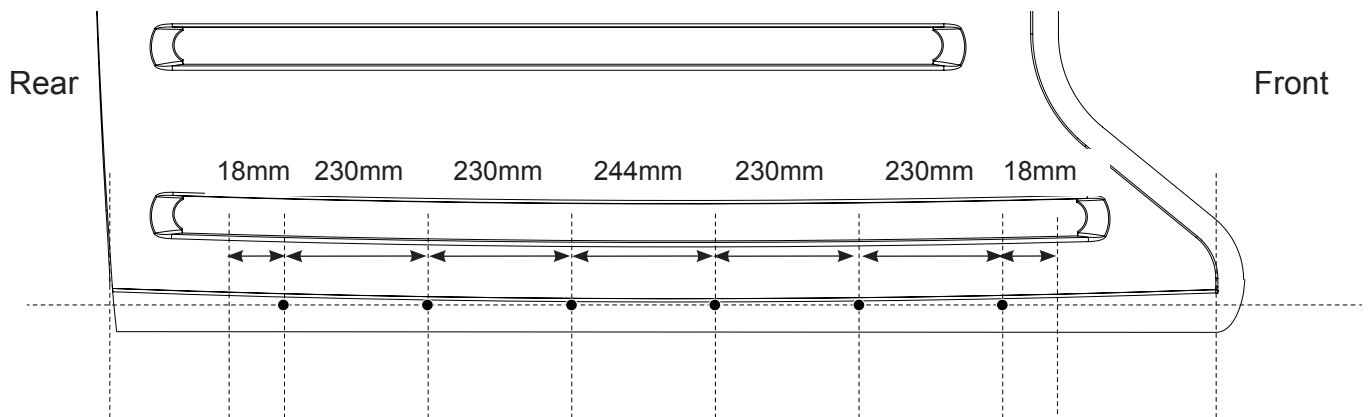

### 7

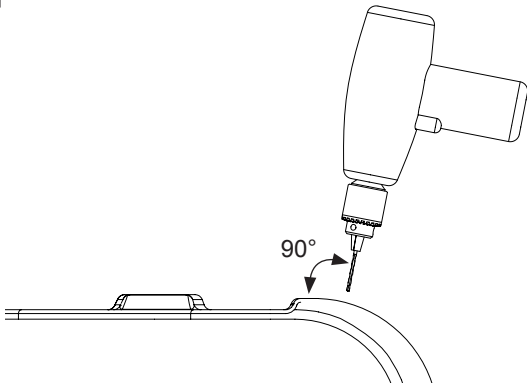

#### Drilling of hardtop.

Drill through perpendicular to the surface using a 6.5mm drill bit. Remove masking tape. Clean hardtop.

### 8 Attach O-rings.

Install rubber O-rings onto each square head bolt except the those used on the end caps. Locate bolts in the C-groove on underside of track.

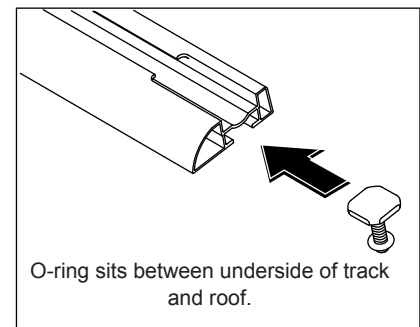
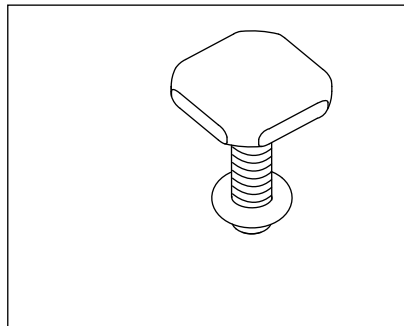
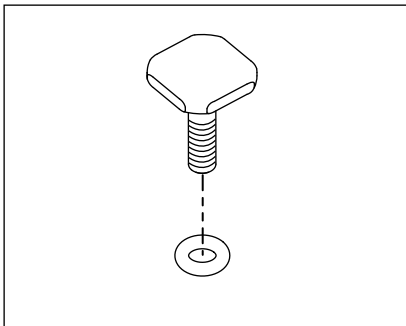



# Jeep Wrangler JK MY11 hardtop

**9 End caps.**  
Insert end caps into each end of the track.

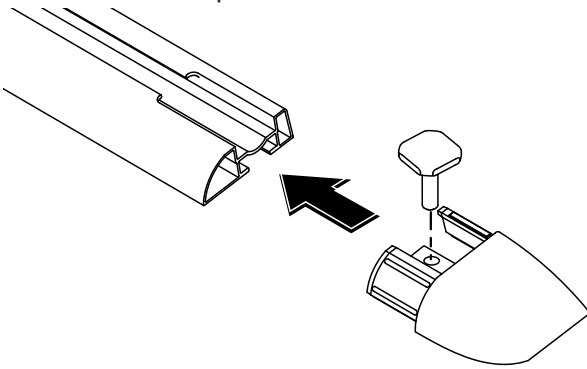

**10 Backing tape.**  
Peel white backing tape off underside of track.

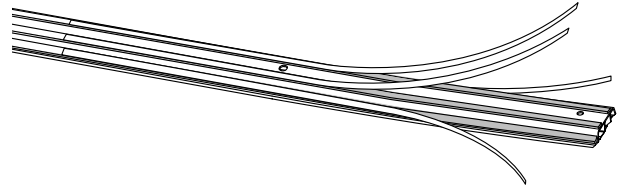

**11 Attach track.**  
Align each bolt so that it drops into its corresponding hole.

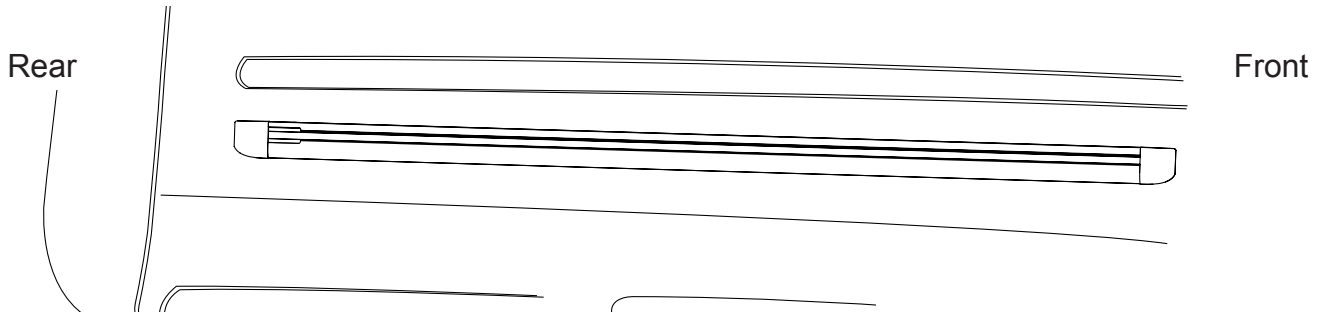
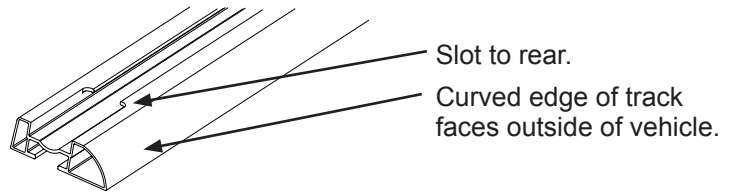

**12 Fasten Track.**  
Finger tighten all square head bolts to locate the track. Once all threads have engaged start tightening from the centre and work towards the ends. **DO NOT OVER TIGHTEN.**

