

HEADER INSTALLATION INSTRUCTIONS

D369

1964-75 Chevelle, El Camino

265-400 SBC

NOTE:

- Read Instructions before attempting installation, additional parts may be required.
- Will fit with 168 tooth flywheel only with Mini Starter
- Will NOT fit 64-67 Chevelle/El Camino with Air Conditioning
- If the alternator is mounted to the exhaust manifold, bracket #H7606 will be required
- 68-75 A/C cars with the compressor mounted to right side manifold will require bracket #H7608



This product is Legal for use on 1974 Non-Catalyst equipped vehicles and is considered a "Replacement Part" per California Air Resources Board regulations, as long as ALL emissions sensitive components are retained, Including EGR, A.I.R., Heat Risers etc. Failure to retain any of these components , or use on 1975 or newer Catalyst equipped vehicles, would render this product Illegal for Street or Off Highway use and may only be used for Closed Course Competition.

PerTronix® thanks you for choosing **DOUG'S HEADERS**, the best fitting, highest quality header on the market. In order to realize the full potential of our good fit, please read and understand these instructions completely prior to starting work.

CHECK TO MAKE SURE YOU RECEIVED THE PROPER PARTS FOR YOUR APPLICATION. THE HEADER NUMBER WILL BE STAMPED ON THE ENGINE FLANGE. IF YOU ARE UNSURE YOU HAVE RECEIVED THE PROPER PARTS CALL BEFORE YOU START WORK.

BE SURE TO WORK SAFE! WHENEVER YOU WORK UNDER THE VEHICLE BE SURE THAT IT IS LOCATED ON LEVEL, SOLID GROUND AND IS SUPPORTED BY ADEQUATE SAFETY STANDS!
REMEMBER: HOT ASPHALT WILL NOT SUPPORT MOST JACK STANDS!

Many factors affect the installation of headers, some of which are broken or aftermarket motor mounts, accidents that impact the configuration of the frame, and/or the installation of different engines or aftermarket cylinder heads. Most installations require some welding. If you are uncomfortable with welding operations, we recommend that you contact a professional exhaust system specialist to install your new headers.

Attention Customers breaking in new engines: Due to the extreme heat generated during the break-in process, the appearance of the ceramic coating may be altered in certain areas. The protection characteristics and thermal barrier properties of the coating is never compromised. It is recommended that a cast iron manifold or old set of headers be used for this process. **Notice:** The coating of these headers can be marred or scratched during installation. If the header needs to be returned and is damaged, you will be charged for recoat.

DISASSEMBLY

1. Disconnect the negative battery cable from the battery.

2. If a car lift is not available, raise the vehicle 2 feet or higher and support it with adequate safety stands. Make sure the vehicle is on a flat solid surface and is stable.
3. Apply penetrating oil to all nuts and bolts to be removed.
4. Remove and mark all spark plug wires and then remove all spark plugs.
5. Disconnect the head pipes from the exhaust manifolds and remove the manifolds.
6. Remove the alternator, dipstick, dipstick tube, clutch linkage, and oil filter. Remove the starter. Remove the power steering bracket.
7. On cars equipped with air conditioning, unbolt the compressor and lay aside.
8. The clutch linkage will need to be modified as in **Illustration A**.
9. Clean the cylinder head exhaust mounting surface of any old gasket material and carbon.

ASSEMBLY

1. Starting on the Driver's side, place a board between the oil pan and floor jack. Remove the center bolt from the driver's side motor mount and then jack the motor up about 1".
2. From below, slip the header up into place. It may be necessary to remove the frame support rods (72-75) in order to get the header in. It also may be necessary to bend the brace to reinstall, see Illustration D.
3. Lower the motor, replace the motor mount bolts and check for header clearance. Shift linkage may need to be slightly bent.
4. With the gasket in place, use the supplied header bolts and lock-washers, apply a small amount of anti-seize to the bolts and start the most restrictive bolts first. Tighten evenly from center out.
5. Replace the clutch linkage, oil filter, dipstick tube and dipstick and alternator.
6. Models with generator/alternator on the left side may need to purchase Doug's brackets H7606 and H7607. See **Illustration B**.
7. On cars with power steering, use the spacer provided and the long bolt from the stock exhaust manifold to remount the power steering. **See Illustration C**.
8. On the Passenger's side, place a board between the oil pan and floor jack. Remove the center bolt from the pass side motor mount and then jack the motor up about 1".
9. From below, slip the header up into place. It may be necessary to remove the frame support rods (72-75) in order to get the header in. It also may be necessary to bend the brace to reinstall, see Illustration D.
10. With the gasket in place, use the supplied header bolts and lock-washers, apply a small amount of anti-seize to the bolts and start the most restrictive bolts first. Tighten evenly from center out.
11. Replace the starter and connect the wires. Reroute the wires as needed for clearance.
12. Cars with the A/C compressor on the pass side will need bracket #H7608.
13. Install the reducers and determine the connection to the exhaust system.
14. Weld the reducers to the exhaust system and install them onto the headers utilizing the gaskets and bolts supplied.
15. Install the spark plugs and connect the wires to the proper plug. It may be necessary to reroute wires to clear the headers.
16. Check to make sure that all the wiring, brake lines, hoses, etc. are clear of the headers or any exhaust component.
17. Make sure all necessary brackets and accessories have been replaced and secured.
18. Connect the battery cable.

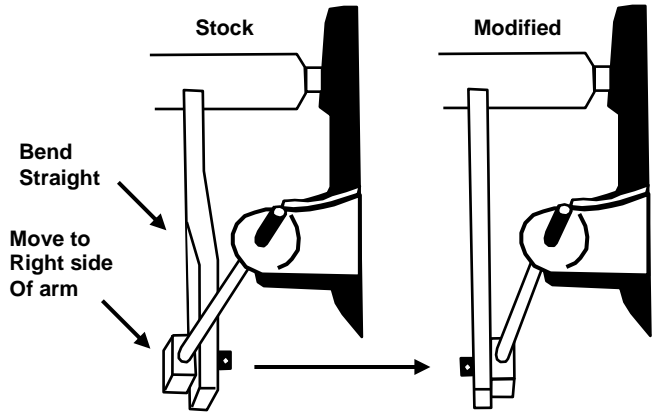

**Illustration A:
Clutch Linkage Modification**

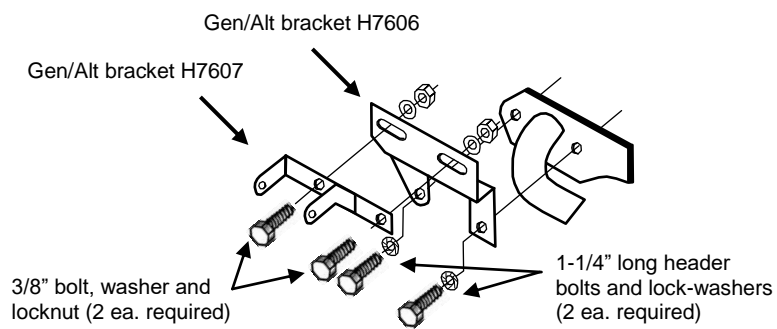

**Illustration B:
Gen/Alt Bracket**

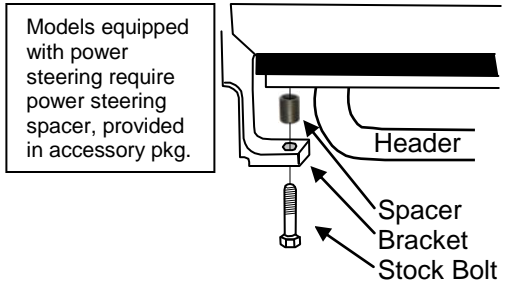

**Illustration C:
Power Steering Bracket**

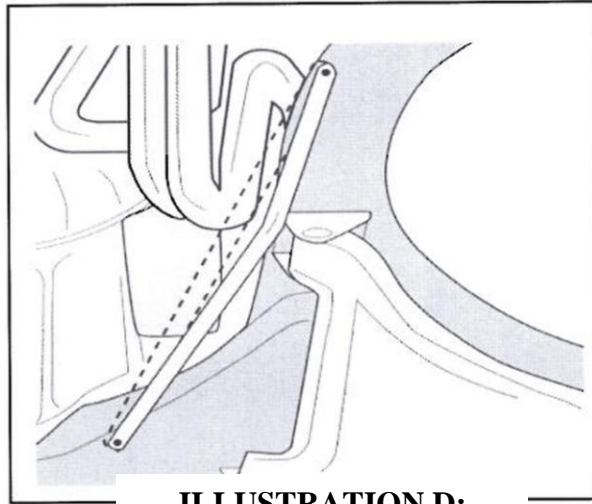

ILLUSTRATION D:
72-75 Braces

START THE ENGINE

Start the engine and allow it to warm up to operating temperature. Check for any unusual noises or exhaust leaks. If every thing is OK, stop the engine and tighten all bolts while the engine is still warm. **NOTE:** Check the bolts periodically to make sure they have not loosened. Re-tighten after the first 500 miles and then again at 1000 miles

IMPORTANT CHECK LIST

- Be sure that all brake lines and fuel lines are clear of headers and/or connector pipes.
- All spark plug wires, battery cables, or other electrical components should be clear of headers and/or connector pipes.
- If dipstick tube was removed, make sure it is installed properly and that the dipstick has been replaced.
- Double-check the tightness of all bolts including brackets and accessories.

PARTS LIST

<u>Qty</u>	<u>Description</u>		
1	Left side header	1	Right side header
2	Header gaskets	2	3" reducers
1	Spacer	2	3", 3 bolt collector gaskets
12	3/8"-16 x 1" header bolts	6	3/8"-16 x 1 1/4" hex head cap screws
6	3/8"-16 hex nut	18	3/8" lock-washers

WARNING:

This product can expose you to chemicals including Lead, Nickel, Cadmium and Chromium which are known to the State of California to cause cancer and birth defects or other reproductive harm. For more information go to www.P65Warnings.ca.gov