

## Tundra 4WD 2.5-3" Leveling Lift Kit

### Parts:

2 - Front Strut Spacers	2 - Differential Spacers
4 - Front Strut Spacer Shim Plates	3 - Skid Plate Spacers
8 - 3/8" Nut	3 - 8mm Retaining Washer
8 - 3/8" Lock Washer	2 - 9/16" x 6" Bolt
3 - 8mm x 30mm Bolt	2 - 9/16" Locknut
	2 - 9/16" Washer

## PRE-INSTALLATION

### Professional installation by a certified technician is strongly recommended.

*Not responsible for altered products. No claims are made regarding any lifting devices. Any and all claims implied in this document excluded.*

#### NOTES:

The following instructions assume the use of factory wheels with maximum size 305/65-18 (33-inch) tires.

Before starting installation, record the front and rear ride height of the vehicle. Calculate the amount of lift needed to level the vehicle. Strut spacer provides about 2 1/4" of lift. Each additional spacer shim provides another 3/8" of lift.

#### REQUIRED TOOLS:

10mm Wrench	12mm Wrench	14mm Wrench	19mm Wrench
22mm Wrench	24mm Wrench	9/16" Wrench	13/16" Wrench
Hammer			

#### Torque Specs:

Size	Grade 5	Grade 8	Size	
3/8"	30 ft/lbs	35 ft/lbs	8mm	25ft/lbs
9/16"	95 ft/lbs	130 ft/lbs	10mm	32ft/lbs
			12mm	70ft/lbs
			14mm	95ft/lbs
			16mm	200ft/lbs
			18mm	475ft/lbs

## INSTALLATION INSTRUCTIONS Front

**STEP 1:** Park on level surface. Chock rear wheels. Jack up front of vehicle.

**STEP 2:** Place jack stands under frame rails directly behind lower control arm mounts.

**STEP 3:** Remove front wheels.

**STEP 4:** Remove sensor wire bracket, careful not to stretch or damage wire. (10mm Wrench - Save factory hardware)

**STEP 5:** Remove upper strut nuts. (14mm Wrench - Save factory hardware)

**STEP 6:** Remove sway bar link from lower control arm. (19mm Wrench - Save factory hardware)

**STEP 7:** Loosen lower control arm bolts, but do not remove. (24mm Wrench) Swing lower control arm down.

**STEP 8:** Remove brake line bracket from knuckle. (12mm Wrench)

**STEP 9:** Remove upper ball joint nut. (19mm Wrench) Hit knuckle on side with hammer to dislodge taper lock.

**STEP 10:** Remove lower strut bolts. (22mm Socket) Remove strut.

**STEP 11:** Install included strut spacer on top of strut with factory hardware. **IMPORTANT: Flat side of spacer must face frame rail.**

**STEP 12:** Add one or two spacer shims on top of strut spacer if needed - match flat side with spacer.

**STEP 13:** Remove driver-side and passenger-side differential front mounting bolts.

**STEP 14:** Install included 1" spacers between differential mounts and frame. Secure with included 9/16" x 6" bolts. (13/16" Wrench)

**STEP 15:** Reinstall strut in factory mount. **IMPORTANT: Flat side of spacer must face frame rail.** Secure with included 3/8" nuts and lock washers on upper mount. (9/16" Wrench) Secure to bottom arm with factory hardware. (22mm Socket)

**STEP 16:** Insert included 8mm x 30mm bolts in skid plate. Place spacers on bolts, followed by retaining washers to keep spacers in place. Reinstall skid plate on vehicle.

## POST-INSTALLATION

**STEP 1:** Check for proper torque on all fasteners. Check steering for proper working order and check for interference. Test brake system. Check clearance between all rotating, mobile, fixed and hot parts.

**STEP 2:** Check distance between tire sidewall and the brake hose during full-turn to full-turn steering sweep. Do not skip this step! Any contact may result in component failure.

**STEP 3:** Adjust headlights to proper alignment.

**MAINTENANCE:** After 500 miles, re-torque all fasteners. (Recommended every 1000 miles thereafter) Have all suspension, driveline and steering components inspected by a certified technician during routine maintenance (Recommended every 3000 miles)

# 2007-16 Tundra 4WD 2.5-3" Leveling Lift Kit

## Parts:

- 2 - Rear Spacer Blocks
- 4 - U-Bolts
- 8 - U-Bolt Nuts

## PRE-INSTALLATION

**Professional installation by a certified technician is strongly recommended.**

*Not responsible for altered products. No claims are made regarding any lifting devices. Any and all claims implied in this document excluded.*

### REQUIRED TOOLS:

Impact Wrench                      Floor Jack or Lift  
Wrenches                              Jack Stands

### Torque Specs:

Size	Grade 5	Grade 8	Size	Class 8.8	Class 10.9
5/16"	15 ft/lbs	20 ft/lbs	6MM	6ft/lbs	8ft/lbs
3/8"	30 ft/lbs	35 ft/lbs	8MM	16ft/lbs	22ft/lbs
7/16"	45 ft/lbs	60 ft/lbs	10MM	40ft/lbs	45ft/lbs
1/2"	65 ft/lbs	90 ft/lbs	12MM	54ft/lbs	70ft/lbs
9/16"	95 ft/lbs	130 ft/lbs	14MM	89ft/lbs	117ft/lbs
5/8"	135 ft/lbs	175 ft/lbs	16MM	132ft/lbs	175ft/lbs
3/4"	185 ft/lbs	280 ft/lbs	18MM	182ft/lbs	236ft/lbs

## INSTALLATION INSTRUCTIONS Rear

- STEP 1:** Chock front weels and jack up rear of vehicle. Place jack stands under frame rails.
- STEP 2:** Support rear axle with jack. Work on one side of vehicle at a time.
- STEP 3:** Disconnect ABS brackets from axle.
- STEP 4:** Remove lower shock bolt and disconnect shock.
- STEP 5:** Remove all nuts on factory U-bolts and remove axle mounting plate.
- STEP 6:** Lower rear axle slowly until there is enough space to install block between axle and leaf spring. Remove factory U-bolts.
- STEP 7:** Position new block and align with locating pins on leaf spring.
- STEP 8:** Raise axle until block contacts leaf spring.
- STEP 9:** Install new U-bolts over bumpstop bracket and leaf spring.
- STEP 10:** Re-install axle mounting plate.
- STEP 11:** Secure U-bolts with included nuts and tighten.
- STEP 12:** Lower vehicle and torque all hardware.
- STEP 13:** Re-install ABS brackets on axle.

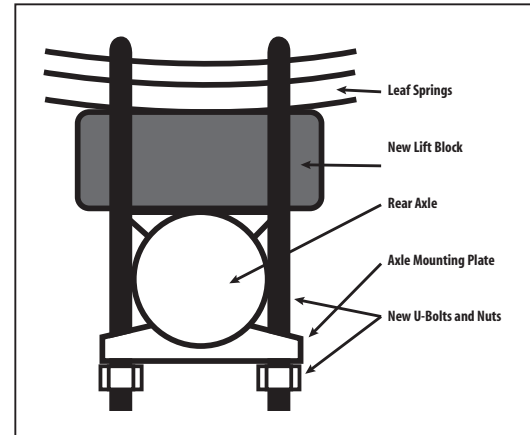

## POST-INSTALLATION

- STEP 1:** Check for proper torque on all fasteners. Check steering for proper working order and check for interference. Inspect and test brake system. Check clearance between all rotating, mobile, fixed and hot parts. Check clearance between exhaust and brake lines, fuel tank and lines, wiring harness and floorboards.
- STEP 2:** Re-torque u-bolts and other fasteners after first 100 miles, then again after another 100 miles.
- STEP 3:** Adjust headlights to proper alignment.

**MAINTENANCE:** After 500 miles, re-torque all fasteners. (Recommended every 1000 miles thereafter) Have all suspension, driveline and steering components inspected buy a certified technician durning routine maintenance (Recommended every 3000 miles)