



2501 Ludelle Street  
 Fort Worth, Texas 76105  
 817-244-6212 Phone • 817-244-4024 Fax  
 888-350-6588 Sales • 800-423-9696 Tech  
 E-mail: [painless@painlessperformance.com](mailto:painless@painlessperformance.com)  
 Web: [www.painlessperformance.com](http://www.painlessperformance.com)

## EMISSIONS KIT FOR '99-'02 GEN III VORTEC ENGINES Part #60322, 60323

This kit includes the wiring for the rear oxygen sensors and the fuel tank pressure sensor.

### STEP 1 - ROUTING THE WIRES

These kits are designed to piggy back the Painless harnesses #60217 and #60218. Begin by locating the red wire (with a ring terminal), the tan/white, purple/white, pink and black wires that are tie wrapped together, also the tan, purple, pink and black wires that are tie wrapped together, as well as the orange/black, green and gray wires that are tie wrapped together, and a black wire (with a ring terminal). Pass these wires through the Fuel Injection Harness grommet, from the passenger compartment into the engine compartment. These wires are terminated with the correct terminals and wire seals to fit the connectors supplied in the bag kit.

**NOTE:** DO NOT INSTALL CONNECTOR HOUSING ON THESE WIRES UNTIL AFTER THEY HAVE BEEN PASSED THROUGH THE GROMMET IN THE FIREWALL.

**CAUTION:** BE CAREFUL ROUTING THE WIRES THROUGH THE FIREWALL TO AVOID DAMAGING THE TERMINALS ON THE ENDS OF THE WIRES.

### STEP 2 - INSTALLATION OF CONNECTORS IN THE ENGINE COMPARTMENT

In the bag kit you will find three connector housings and three Terminal Position Assurance locks (TPA). Take one of the four-way connector housings and insert the tan/white, purple/white, pink and black wires into the A, B, C, and D cavities until the terminal locking tang engages, as shown in **Illustration 1**. Repeat this step for the tan, purple, pink and black wires using the remaining four-way connector. The connector with the striped wires will be connected to the left oxygen sensor and the other to the right.

**NOTE:** THE TERMINAL WILL ONLY FIT ONE WAY INTO THE CONNECTOR. DO NOT TRY TO FORCE THE TERMINAL.

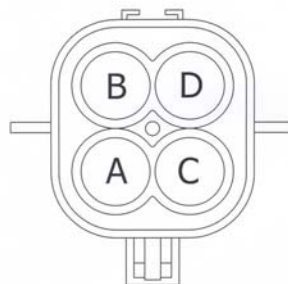
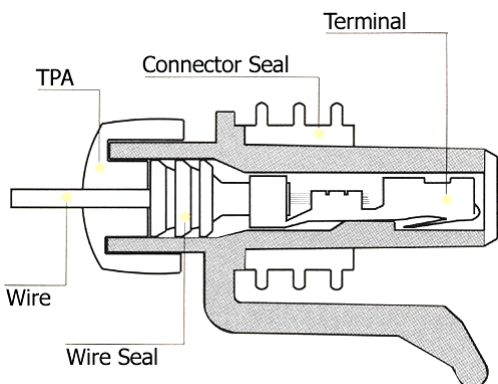

LEFT SIDE	RIGHT SIDE
A-TAN/WHT	A-TAN
B-PUR/WHT	B-PUR
C-BLK	C-BLK
D-PNK	D-PNK

**ILLUSTRATION 1** Rear Oxygen Sensor Connector pin out

Be sure to use the black TPA on the connector housings after the wires have been inserted into the proper cavities. These connectors can now be routed and plugged into the rear oxygen sensors located behind or rear of the catalytic converter.

Take the black three-way connector housing and insert the black wire into the A cavity, the green wire into the B cavity and the gray wire into the C cavity until the locking tangs engage, as shown in **Illustration 2**.

**NOTE: THE TERMINAL WILL ONLY FIT ONE WAY INTO THE CONNECTOR. DO NOT TRY TO FORCE THE TERMINAL.**

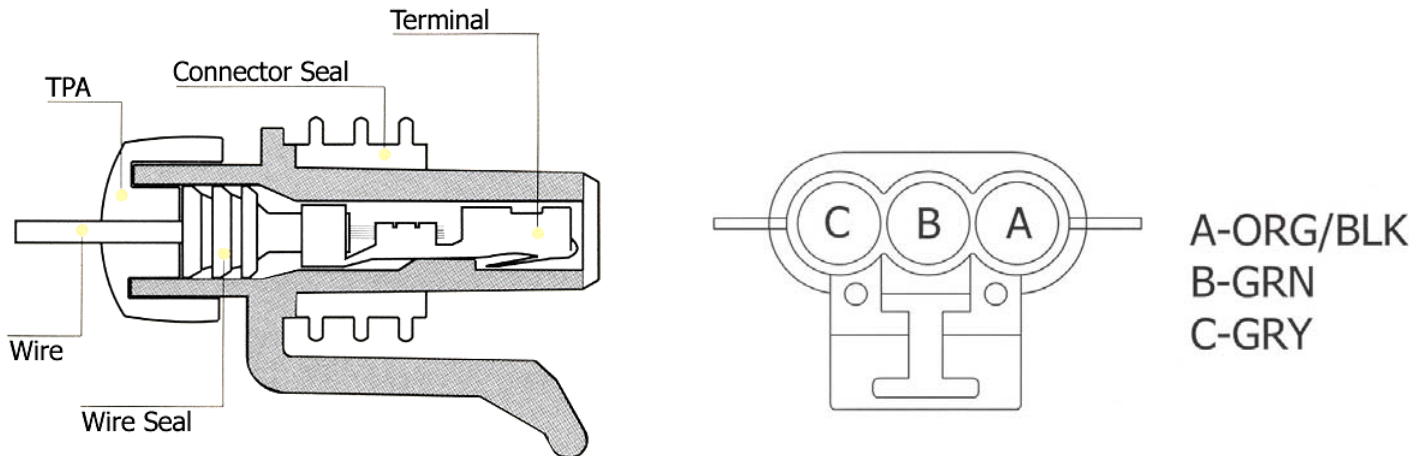

### **ILLUSTRATION 2** Fuel pressure sensor connector pin out

Be sure to install the white TPA on the connector housing after the wires have been inserted into the proper cavities. This connector can now be routed and plugged into the fuel tank pressure sensor located on fuel tank pump assembly.

Connect the red wire with the ring terminal to the starter solenoid "BATT" terminal.

### **STEP 3 - UNPLUGGING THE COMPUTER**

**CAUTION: REMOVING THE COMPUTER CONNECTORS FROM THE COMPUTER WHILE THE IGNITION IS ON WILL DAMAGE THE COMPUTER!**

First, make sure that the battery is disconnected. Unplug both computer connectors. BE CAREFUL NOT TO DAMAGE THE COMPUTER PINS! Using a permanent marker, mark both metal housings with their respective secondary lock color. This is to prevent any confusion of which connector is which after removing the secondary locks. Remove the red and blue secondary locks from the computer connectors by releasing the retaining clips and pulling them out and away from the connector assemblies.

### **STEP 4 - CONNECTING THE REAR OXYGEN SENSORS AT THE COMPUTER**

Using **Illustration 3** for reference, look on the rear side of the blue 80 pin computer connector housing for the cavity marked "25". Insert the TAN wire here. Push in until the locking tang engages. Next, insert the TAN/WHITE wire terminal into the "28" cavity. Next, insert the PURPLE wire terminal into the "65" cavity and the PURPLE/WHITE wire terminal into the "68" cavity. This will complete all of the oxygen sensor wires.

## WIRE SIDE VIEW OF THE BLUE COMPUTER CONNECTOR

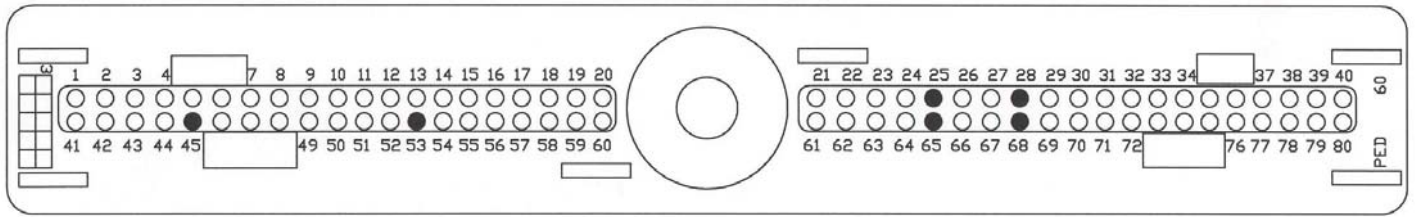

## WIRE SIDE VIEW OF THE RED COMPUTER CONNECTOR

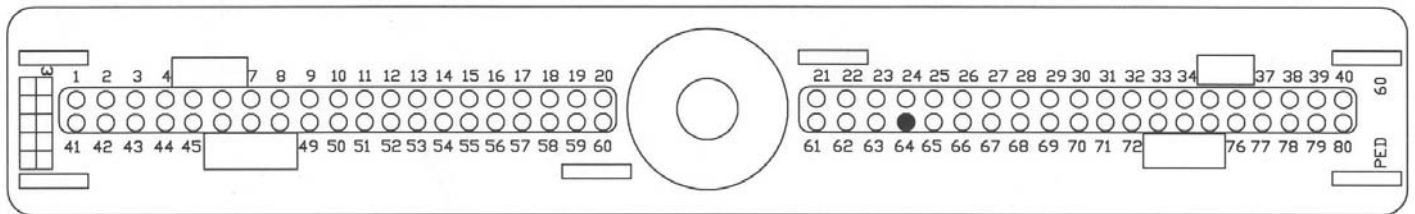

**ILLUSTRATION 3** Computer connector pin out

### **STEP 5 - CONNECTING THE FUEL TANK PRESSURE SENSOR AT THE COMPUTER**

Using **Illustration 3** for reference, look on the rear side of the blue 80 pin computer connector housing for the cavity marked "45." Insert the GRAY wire here. Push in until the locking tang engages. Next, insert the ORANGE/BLACK wire terminal into the "53" cavity. Look at the rear side of the red 80 pin computer connector housing for the cavity marked "64." Insert the GREEN wire terminal into the "64" cavity. This will complete all of the fuel tank pressure sensor wires.

### **STEP 6 - REPLACING THE COMPUTER CONNECTORS AT THE COMPUTER**

Replace the red and blue secondary locks on the two computer connectors. Be careful to line up the "fingers" on the locks with the connector openings. Once you have the secondary locks in place, reinstall the computer connectors into the computer. The relays and fuse holders should be positioned near the computer of the Painless Fuel Injection Harness. Screws and mounting hardware for securing the relays and fuse holders is included in the bag kit.

**CAUTION: USE CARE WHEN RE-INSTALLING THE COMPUTER CONNECTOR, TO AVOID DAMAGING THE COMPUTER PINS.**

### **STEP 7 – POWER AND GROUND**

Take the pink wire located near the relays and route it to a switched 12 volt source, this 12 volt source can come from the painless fuse block or the factory fuse block. NOTE: THE PINK WIRE IS ONLY A RELAY ACTIVATION THAT WILL PULL LESS THAN A 1 AMP LOAD. The relay base is designed to lock onto the relay base of the Painless fuse block or it can be mounted using the screw provided in this kit. Terminals are provided to piggy back this wire onto one of the vehicles existing fuses. Locate the black wires with a ring terminal and use one of the screws from the bag kit to ground it to the chassis.

NOTE: DOUBLE CHECK ALL ROUTING, MAKING SURE THAT THERE IS ENOUGH SLACK TO ALLOW FOR ANY ENGINE MOVEMENT. REINSTALL ANY GROMMETS OR OTHER PARTS TAKEN OFF. START AND DRIVE THE VEHICLE FOR AT LEAST THIRTY MINUTES, THEN CHECK FOR ANY TROUBLE CODES STORED IN THE COMPUTER. PAINLESS WIRING OFFERS A TECHNICAL ASSISTANCE LINE TO ANSWER ANY QUESTIONS YOU MAY HAVE. THE NUMBER IS (800)423-9696. PHONES ARE ANSWERED MONDAY THROUGH FRIDAY FROM 8 AM TO 5 PM CENTRAL TIME, NOT INCLUDING HOLIDAYS. PLEASE LEAVE A MESSAGE IF YOU ARE UNABLE TO REACH US AND WE WILL RETURN YOU'RE CALL AS SOON AS POSSIBLE.

## **Painless Performance Limited Warranty and Return Policy**

Chassis harnesses and fuel injection harnesses are covered under a lifetime warranty. All other products manufactured and/or sold by Painless Performance are warranted to the original purchaser to be free from defects in material and workmanship under normal use. Painless Performance will repair or replace defective products without charge during the first 12 months from the purchase date. No products will be considered for warranty without a copy of the purchase receipt showing the sellers name, address and date of purchase. You must return the product to the dealer you purchased it from to initiate warranty procedures.

**Copyright © 2007 by Perfect Performance Products, LLC**