

PAINLESS[®]

PERFORMANCE PRODUCTS

Wire Harness Installation Instructions

For Installing:

Part #60101 - GM 86-93 TBI Standard Harness
&
Part #60201 GM 86-93 TBI Extended Length Harness

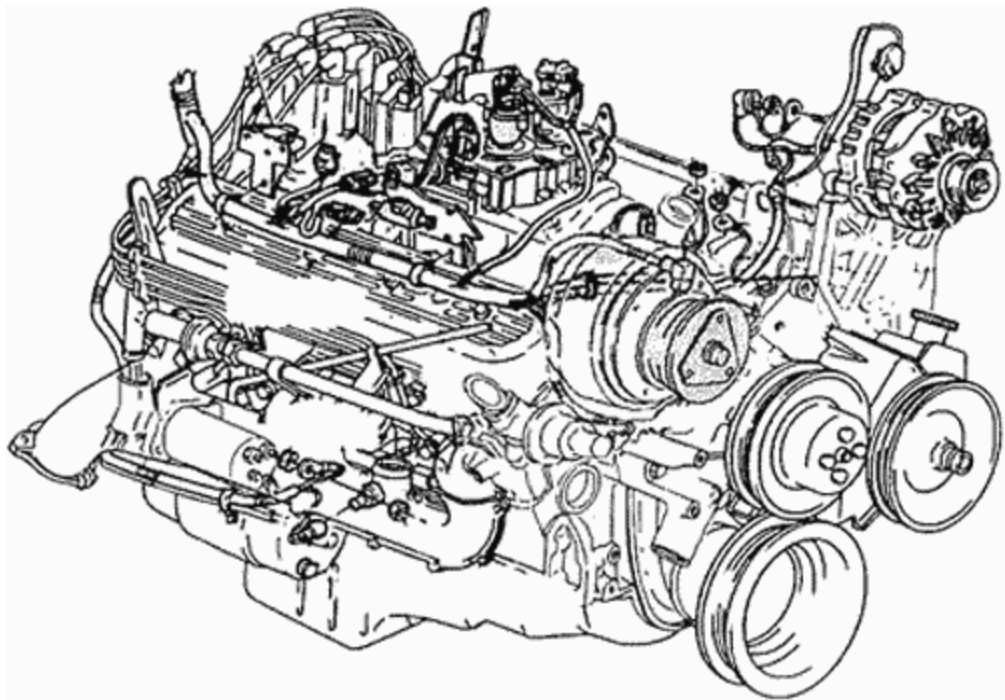

Manual # 90503

Painless Performance Products, LLC

2501 Ludelle Street

Fort Worth, TX 76105-1036

800-423-9696 phone – 817-244-4024 fax

Web Site: www.painlessperformance.com

E-Mail: painless@painlessperformance.com

If you have any questions concerning the installation of this product, feel free to call **Painless Performance Products'** tech line at 1-800-423-9696. Calls are answered from 8am to 5pm central time, Monday thru Thursday, 8am-4:30pm Friday, except holidays.

Here we have provided you with accurate instructions for the installation of this product. However, if you have comments/suggestions concerning these instructions, please call or email us (our contact information can be found at the top of this page or online at **www.painlessperformance.com**). We sincerely appreciate your business.

Painless Performance Products, LLC shall in no event be liable in contract or tort (including negligence) for special, indirect, incidental, or consequential damages, such as but not limited to, loss of property, or any other damages, costs or expenses which might be claimed as the result of the use or failure of the goods sold hereby, except only the cost of repair or replacement.

Should you damage or lose part of your manual, a full color copy of these instructions can be found online at www.painlessperformance.com

Installation Manual: **90503**

10th Edition: August 2001

Copyright © 1996 by Painless Performance Products, LLC

TABLE OF CONTENTS

1.0	Introduction.....	1
2.0	About These Instructions.....	1
3.0	Tools Needed.....	2
4.0	Pre-Installation and Harness Routing Guidelines.....	2
4.1	Transmission Lockup Function.....	2
4.2	Compatible Parts.....	4
5.0	General Installation Instructions.....	6
5.1	Grounding the Vehicle.....	7
5.2	Rough Installation.....	7
5.3	Harness Attachment.....	8
5.4	Terminal Installation Instructions.....	8
5.5	Pre-adjustments before starting engine and setting the IAC	9
6.0	GM Throttle Body System Wire Harness Installations	9
6.1	Contents of the 60101 Wire Harness Kits.....	9
6.2	Specific Circuit Connections.....	10
6.2.1	Dash Section Installation.....	10
6.2.2	Throttle Body Injection Engine Group.....	13
6.2.3	Setting the Base Engine Timing	13
6.2.4	Tail Section Installation.....	15
7.0	Trouble Shooting Instructions.....	18
7.1	The "Check Engine" Light.....	18
7.2	Retrieving Trouble Codes from the Computer.....	18
7.3	Tech Help.....	19
8.0	Add On TBI Emissions.....	21

LIST OF FIGURES

Figure 4.1	External Coil Distributor Hookup.....	5
Figure 6.1	Assembly Line Diagnostic Link (ALDL) Connector.....	11
Figure 6.2	Neutral Safety Switch.....	12
Figure 6.3	Brake Switch.....	14
Figure 6.4	Throttle Body Injection Unit.....	16
Figure 6.5	Oxygen Sensor.....	16
Figure 6.6	Knock Sensor.....	17
Figure 6.7	TCC Solenoid.....	17

LIST OF TABLES

Table 4.1	Compatible Parts.....	4
Table 6.1	Sensor and Relay Connections.....	14
Table 6.2	Engine Section.....	15
Table 9.1	Diagnostic Trouble Codes.....	20

LIST OF DIAGRAMS

Diagram 1	TBI Emissions.....	21
Diagram 2	Brake Switch Connection.....	24

1.0 INTRODUCTION

You have purchased what we at Perfect Performance Products, Inc. believe to be the most up-to-date and easiest-to-install automotive fuel injection harness on the market. It is designed for easy installation, even if you have no electrical experience.

This harness is designed to be a complete wiring system for the fuel injection system on General Motors throttle body (5.0L and 5.7L) injection engines. This includes all wiring that is needed by the computer to run and control the fuel injection system. This harness will also work on an '86-93 4.3 liter V6, as well as a 454 (7.4L) engine.

Most of the wiring in the harness has been pre-terminated to the proper connector and all wire is rated at 125°C and has been GM color-coded.

These fuel system harnesses have been divided into three major groups:

ENGINE GROUP	Includes wiring for the fuel injectors, distributor, sensors and tail section.
DASH GROUP	Includes ignition feed wire, assembly line diagnostic link (ALDL) connector, check-engine light, gearshift position wiring and brake switch wire.
TAIL GROUP	Includes wiring for the fuel pump, torque converter and vehicle speed sensor

2.0 ABOUT THESE INSTRUCTIONS

These instructions provide information for the installation of the 60101 and 60201 Throttle Body Injection Wire Harness Kit. The contents of these instructions are divided into major **Sections**, as follows:

- 1.0 Introduction
- 2.0 About These Instructions
- 3.0 Tools Needed
- 4.0 Pre-Installation and Harness Routing Guidelines
- 5.0 General Installation Instructions
- 6.0 60101 and 60201 Throttle Body Harness Kit
- 8.0 Trouble Shooting Instructions and Trouble Codes

Sections are further divided into **Paragraphs** and **Steps**. Throughout, the **Figure** numbers refer to illustrations and the **Table** numbers refer to information in table form. These are located in or near the sections or paragraphs to which they correspond. Always pay careful attention to any *Notes* or any text labeled **CAUTION**.

3.0 TOOLS NEEDED

In addition to your regular tools, you will need, at least, the following:

Crimping Tool	<i>Note: Use a quality tool to avoid over-crimping.</i>
Wire Stripper	
Continuity Tester	<i>Caution: Do <u>not</u> use a test light to test the computer or sensor wiring or you will damage the computer.</i>
Electric Drill	
1-1/4" Hole saw	(for the rubber grommet in the firewall)

4.0 PRE-INSTALLATION AND HARNESS ROUTING GUIDELINES

The installation of your harness kit consists mainly of two parts:

- The physical routing, positioning, and securing of the harness, wire groups, and individual wires and connectors.
- The proper electrical connection of the individual circuits.

These two major tasks are not separate steps, but are integrated together. That is, you will route some wires and make some connections, route some more wires and make some more connections.

We cannot tell you how to physically route the harness in your automobile. That depends a great deal upon the particular make of automobile and to what extent you want to secure and conceal the harness. We do offer some general guidelines and routing practices starting in **Paragraph 4.3**, GENERAL installation instructions in **Section 5.0**, and precise instructions concerning the electrical connections you will have to make beginning in **Section 6.0**. To help you begin thinking through the installation of your wire harness, read the following sections:

4.1 VEHICLE SPEED SENSOR AND TRANSMISSION LOCKUP FUNCTION

Before you install the harness, please decide the following things:

- a. Are you going to use a 700 R4 Lockup Transmission that you want the computer to control the lockup on?
- b. Does the engine have to be emissions legal; i.e. does the EGR valve and /or air solenoid, and diverter valve need to be connected?

If you answered yes to either or both of these questions then you must connect the wires labeled VSS to a vehicle speed sensor that will provide a two (2) pulse signal to the computer. The Throttle Body the sensor should output a square wave.

If you answered no to both of these questions then you may choose not to use a vehicle speed sensor, but the vehicle will operate more efficiently with one.

If you are going to use a vehicle speed sensor, take the orange/black and black/white wires in the dash section (labeled for the park/neutral indicator switch) and connect them to the Park/Neutral Indicator Switch, **which is designed to tell the computer the transmission is in park**, as instructed in 6.2.1, Step D and Figure 6.2. Do not connect the wires together.

Important: *The orange/black and black/white wires in the dash section that are labeled for the park/neutral indicator switch are to be connected to the **park/neutral indicator switch**, NOT A NEUTRAL SAFETY SWITCH. Under no circumstances should you connect these wires to a neutral safety switch. (A park/neutral indicator switch is a switch that tells the computer when the vehicle is in park or neutral, but a neutral safety switch is a switch that keeps the vehicle from starting unless it is in park or neutral.) You should never connect the orange/black and black/white wires to the vehicle speed sensor wiring.*

If you are not going to use a vehicle speed sensor then you will take the orange/black and black/white wires in the dash section (labeled for the park/neutral indicator switch) and connect them together.

- 4.1.1** If you do NOT wish to use the lockup function, tape off and store the single purple wire, marked brake switch, in the dash group and the 4-position square connector in the tail section.
- 4.1.2** If you ARE going to use the lockup circuit then you MUST have a vehicle speed sensor (VSS) and the correct brake switch. These are necessary to make the lockup function work correctly. The brake switch should be closed (electrically connected) when the brakes ARE NOT being applied and open (not electrically connected) when the brakes ARE being applied. This is the opposite of a standard brake light switch. The vehicle speed sensor lets the computer know how fast the wheels are turning
- 4.1.3** Regardless of whether you use the lockup function, the vehicle speed sensor (VSS) must be used and is needed by the computer so that it can command the emissions control devices on the engine. This part is necessary if you want your vehicle to be street-legal.

GM THROTTLE BODY INJECTION (TBI) SYSTEM: The engine and the 60101 and 60201 harnesses are designed to use a manifold absolute pressure (MAP) sensor and an electronic spark control (ESC) module as well as the other wiring that the computer needs to operate.

Throttle Body Injection 60101 & 60201

Main Computer.....	1227747 or 16121154	Oil Pressure Switch.....	25036553 or D1818
Brake Switch.....	25524845	Distributor to Coil Wiring.....	PPP 60124
Neutral Safety Switch.....	15705308	Coil Power/Tach Pigtail.....	PPP 60125
Manifold Absolute Pressure Sensor.....	16137039	EGR Solenoid.....	1997111 or 214-331*
Electronic Spark Control Module.....	16128261	Prom (4.3L).....	16082087
Cal-pack.....	16060836	Prom (5.0L).....	16139492
Coolant Temperature Sensor.....	25036979	Prom (5.7L).....	16139566
Knock Sensor.....	10456018	Prom (7.4L).....	16128359**
Oxygen Sensor.....	AFS 21		
Distributor to Coil Pigtail.....	PPP 60124		

* This Solenoid has been discontinued by G.M. The Replacement # is NAPA CRB22307. Please call Painless for the required PP-680 adapter pigtail for this application.

** Note: This Prom does not control any transmission or torque converter functions.

Table 4.1 Compatible Parts List

4.2 Compatible Parts

4.2.1 PAINLESS PERFORMANCE recommends the use of the following parts. See **Table 4.1 on page 4**. These will meet all requirements and are compatible with Painless Performance harnesses. The following numbers given are GM part numbers except for the vehicle speed sensor (VSS) and mem-cal chips, which are Painless Performance numbers. The main computer part numbers are **REQUIRED** for use with our harnesses. **Note: Distributor to Coil and the Coil Power/Tach Pigtail are used only if you have a “separate coil” distributor.**

The computer part numbers shown in the compatible parts list in **Table 4.1** are **required** part numbers for that application. The use of any other computer may damage the computer, harness or both. Use of the wrong computer will almost certainly cause problems. Please double check to be sure that you have the correct computer part number (it is shown as a service number on the computer itself). The rest of the part numbers shown are for your information only.

4.2.2 If you are using a separate coil type distributor, then you will use the distributor adapter included in the kit. You will also need to obtain the distributor to coil and coil power/tach pigtails either from your local dealer, or the Painless part #'s listed above. The wiring for the separate coil system is shown in **Figure 4.2**.

4.3 Familiarize yourself with the harness by locating each of the harness groups and by looking at the connectors on the wire ends.

4.4 Decide where and how the computer and sensors will be mounted. Painless Performance wire harness kits are designed to mount either under the dash or in the lower kick panel on the right side. They must be no further apart than the wiring will allow (approx. 10 inches). Part number 60201 will allow installation under the front seat.

- 4.5 A good exercise is to lay out the wire harness on the floor beside your vehicle and identify all the connectors and wires. The harness must be routed from the inside of the vehicle out to the engine compartment.
- 4.6 You will want to route the harness through and around open areas. Inside edges provide extra protection from hazards and also provide places for tie wraps, clips and other support.
- 4.7 Route the harness away from sharp edges, exhaust pipes, and the hood, trunk, and door hinges.
- 4.8 Plan where harness supports will be located. Use a support approximately every 6 inches unless the harness routes under the floor carpet.
- 4.9 Allow enough slack in the harness at places where movement could possibly occur (body to frame, frame to engine, etc.).
- 4.10 The wires should be bundled into harness groups. Use tape, nylon ties or Powerbraid.

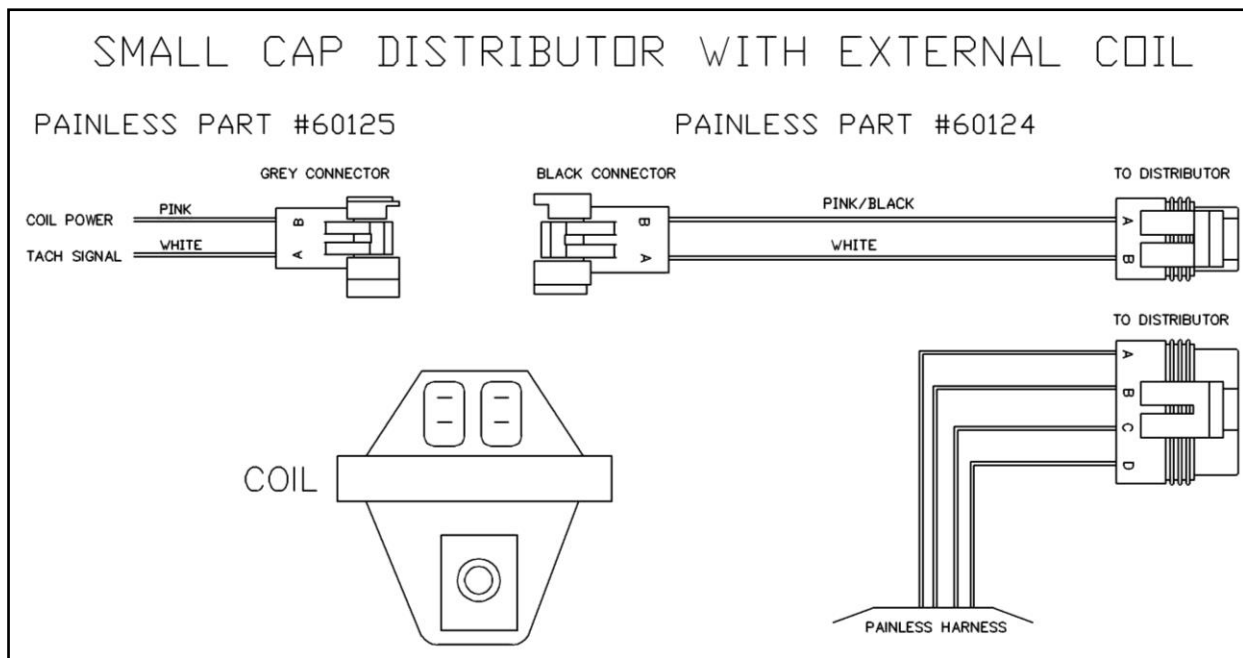
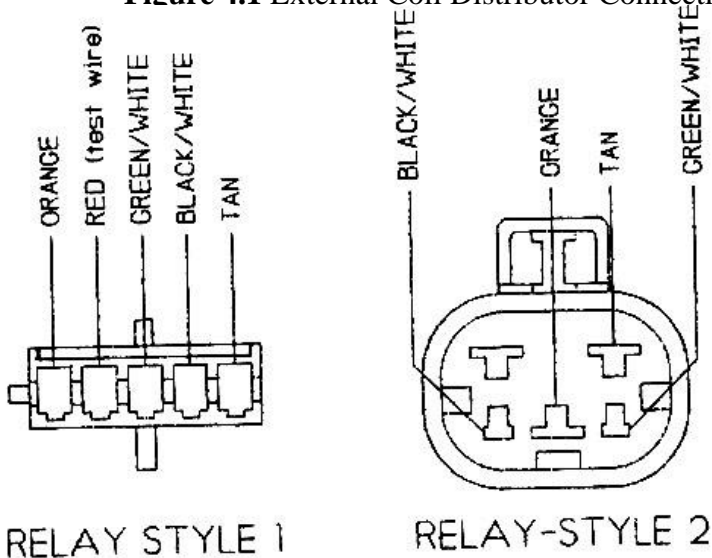

Figure 4.1 External Coil Distributor Connections



NOTE: If your harness has Style 1 relay connector, cut off the end of the Style 2 and cut off Style 1 and

5.0 GENERAL INSTALLATION INSTRUCTIONS

Caution:

- *Do not disconnect the battery or the computer connector(s) while the ignition is on.*
- Do not short any wire in this harness to ground (with the exception of labeled ground wires) or damage to the computer will result.
- *Giving or receiving a jump-start may damage the computer.*
- Do not use a test light when testing computer sensors or computer circuits. Damage to the computer will result!

When routing the wires for the vehicle speed sensor make certain that they are at least 12 inches away from any ignition wiring (spark plug wires, etc.).

Notes:

- All of the adapters, listed in the manual, are included in the wiring kit. You should use or remove them depending on your particular application.
- An oil pressure SWITCH must be used with this harness. **DO NOT BYPASS OIL PRESSURE SWITCH WIRES.**
- If you are using an oil pressure switch that has two or three small pins surrounded by a plastic collar for an electrical connection, an adapter is in the kit.
- There is a normal, small current drain on these fuel injected systems.
- Throttle body systems will NOT work with anything other than a STOCK CAMSHAFT.
- On throttle body systems, the power steering override switch, if so equipped, must be wired IN-LINE on the A/C compressor power wire.
- If you have a throttle body system and your throttle position sensor is different from that shown in **Figure 6.4**, use the adapter in the kit.
- Each connector in this harness is different and will not fit in the wrong place. NEVER FORCE ANY CONNECTOR.
- When connecting the plugs to the computer USE EXTREME CARE to make sure none of the pins in the computer are or have become bent.
- IF YOU HAVE A GM SEPARATE COIL IGNITION SYSTEM ON YOUR ENGINE: use the adapter in the kit.
- FOR YOUR DISTRIBUTOR: The power wire used on the previous distributor should work fine as long as there is no ignition resistor in the circuit. It **must** be a **fused** power wire (14 ga. minimum) that is HOT (+12V) when the ignition switch is in the **START AND RUN** positions. Connect it to the terminal on the distributor cap labeled BAT or to the pink wire on the separate Coil Ignition System. This wire provides power to the ignition coil. YOUR AUTOMOBILE WILL NOT START OR RUN WITHOUT IT.
- The timing (spout) connector for the ignition is near the computer.
- The fuel pump you are using **MUST** be rated at a minimum of **15 pounds PSI** for throttle body systems.
- If you have headers you may have to relocate the knock sensor for proper clearance. See **Figure 6.6**.

Note: The oil pressure switch wires are designed to be connected to an oil pressure switch, not the oil pressure sending unit. An oil pressure sending unit is for a gauge or an indicator light and will only have one terminal on the top. The stock oil pressure switch is cigar shaped and has three terminals. If you wish to use the stock oil pressure switch then you will use the oil pressure switch adapter included with this kit. On the oil pressure switch adapter there are two wires that match the wire colors coming from our harness and there is also an extra wire.

The extra wire is for the factory oil pressure gauge or indicator light, depending on what the switch was originally designed for. You may also obtain a smaller oil pressure switch if you have clearance problems with the original oil pressure switch. This type of switch has two male connectors that will plug directly into the harness.

5.1 GROUNDING THE VEHICLE

A perfectly and beautifully wired automobile will nevertheless have problems if everything is not properly grounded. Don't go to the effort of installing a quality wire harness only to neglect proper grounding.

- 5.1.1** Connect a ground strap or cable (minimum of a 2-gauge wire) from the negative battery terminal to the cylinder block.
- 5.1.2** Connect a ground strap from the engine to the chassis (frame). **DO NOT RELY UPON THE MOTOR MOUNTS TO MAKE THIS CONNECTION.**
- 5.1.3** Connect a ground strap from the engine to the body.

5.2 ROUGH INSTALLATION

Caution: *Disconnect the power from your vehicle by removing the negative battery cable from the battery.*

Note: *Make no wire connections or permanent mounting of any kind at this time.*

- 5.2.1** Position the computer in its intended location.
- 5.2.2** Drill a 1-1/4" hole for the firewall grommet near the computer for the engine group and tail section to pass through.
- 5.2.3** Route the engine group and tail section through the hole. Push the grommet (already installed on the harness) into the hole until it is seated.
- 5.2.4** Route the dash group over to the driver's side of the car.
- 5.2.5** Route the sensor group to the area where the sensors will be mounted.

5.3 HARNESS ATTACHMENT

Note: Harness routing and shaping will be a time-consuming task. Taking your time will enhance the beauty of your installation. Please be patient and take your time.

- 5.3.1 Permanently mount computer. You should mount the parts (sensors, relays, etc.) that will be used for your engine at this time. These parts will vary by application.
- 5.3.2 Mold harness groups to the contour of the dash, engine, frame, etc. Remember to route the harness away from sharp edges, exhaust pipes, hinges, and moving parts.
- 5.3.3 Attach harness groups to your automobile with clips or ties starting at the computer and working your way outward.

Note: Do not tighten tie wraps or mounting devices at this time. Make all harness attachments LOOSELY.

- 5.3.4 When used every 1-1/2" or so on the visible areas of the harness, plastic wire ties make a very attractive assembly. Otherwise, a tie installed in other areas every 6" or so will hold the wires in place securely.
REMEMBER TO TAKE YOUR TIME.

5.4 TERMINAL INSTALLATION INSTRUCTIONS

Note: In the following steps you will be making the circuit connections. Before you start, you should carefully read Sections 6.0 through 8.0, as applicable, and continually refer to the wire connection charts, DOUBLE CHECKING your length calculations before cutting any wire or making any connections. These directions are for the wires which do not have a connector already installed on them.

- 5.4.1 Have all needed tools and connectors handy.
- 5.4.2 Select the correct terminal for the wire and application.
- 5.4.3 Determine the correct wire length and cut the wire. Remember to allow enough slack in the harness and wires at places where movement could possibly occur. DOUBLE-CHECK YOUR CALCULATIONS.
- 5.4.4 Strip insulation away from wire. Strip only enough length necessary for the type of terminal you are using.

Note: In the following step, make sure that the terminal is crimped with the proper die in the crimping tool. An improper crimp will not make a good connection. DO NOT OVER CRIMP.

- 5.4.5 Crimp the terminal onto the wire.
- 5.4.6 Connecting the wires and connectors throughout the harness is a repeating process. Make sure that each wire is first properly routed and then attach. DO NOT ATTACH THEN ROUTE AFTERWARD.

- 5.4.7** When all wires are attached, tighten the mounts and ties to secure harness permanently.
- 5.4.8** Attach the connectors to the computer BEING CAREFUL NOT TO BEND ANY PINS.
- 5.4.9** **Only after all connections have been made** throughout the harness, connect the battery to the vehicle.

Caution: *Be sure the ignition is off when you reconnect the battery or you will damage the computer.*

5.5 PRE-ADJUSTMENTS BEFORE STARTING ENGINE

5.5.1 Setting the IAC and Base Engine Idle Adjustment

- A. Turn on ignition but do not start engine.
- B. Jumper A & B terminals of the ALDL as if you were checking codes.
- C. Wait 30 seconds and then unplug the connector from the IAC motor.
- D. Remove jumper from ALDL.
- E. Start engine and adjust idle speed with adjusting screw at throttle lever (there may be a cap covering the adjusting screw that will need to be removed and discarded).
- F. Shut off engine and disconnect battery for one minute.
- G. Plug the IAC connector back in and then reconnect the battery.
- H. Start engine and check for proper idle speed.

6.0 GM THROTTLE BODY SYSTEM WIRE HARNESS INSTALLATION INSTRUCTIONS (The Painless Performance harness and systems are designed around the 1990 Chevy R/V Pickup)

6.1 Contents of the 60101 and 60201 Wire Harness Kit

Take inventory to see that you have everything you are supposed to have in this kit. If anything is missing, contact the dealer where you obtained the kit or contact Painless Performance at (800) 423-9696. The kit should contain the following items:

- The main wire harness with the connectors already on the ends of most of the wires.
- Distributor, Oil Pressure and Throttle Position Adapters.
- Fuel Injection Installation Instructions P/N 90503 (this booklet).

The following optional parts are **not included** in the kit but are available from Painless Performance:

- Emission Control Device Harnesses (Part # 60310 and 60311).

6.2 SPECIFIC CIRCUIT CONNECTIONS

Note: *If you have not already done so, read Sections 4.0 and 5.0 of these instructions and think through the installation of the harness before securing or cutting any wires.*

6.2.1 DASH SECTION INSTALLATION

The wires in this group consist of the assembly line diagnostic link (ALDL) connector (See **Figure 6.1**), the check engine light (pre-installed into the ALDL mounting bracket), and four other wires.

Note: *You may need to connect the check engine light wires to their mates in the wire harness.*

Caution: *Do not make any connections while the computer is plugged into the harness.*

Note: *Wire color (example: Blk/Wht) is one wire with a stripe. The second color (the stripe) may not be bold. Observe all two-color wires closely.*

- A. Find a suitable location to mount the ALDL connector (using the bracket that the check engine light is mounted in) that will allow access to the front of the connector and still allow you to see the check engine light while driving.
- B. Mount the ALDL connector.
- C. Locate the Pnk/Blk wire and attach it to a 12V **fused** power source.
POWER IS REQUIRED WHEN THE KEY IS IN THE START AND RUN POSITION
- D. Locate the Orn/Blk and Blk/Wht wires in the dash group. These two wires are for the Park/Neutral Selector Switch, NOT the Neutral Safety Switch. If you have a GM column then you can use the combination switch P/N 15679680 and wire it as shown in **FIGURE 6.2**.

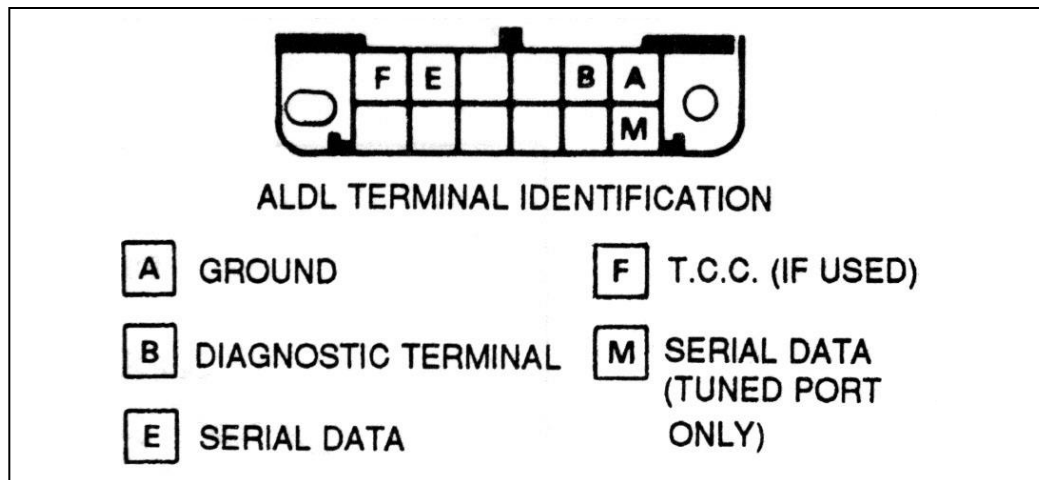

Figure 6.1 Assembly Line Diagnostic Link (ALDL) Connector

Caution: *Do not connect these wires using directions from different instructions. You may damage the computer.*

1. If you are NOT using a Vehicle Speed Sensor (VSS) or a Park/Neutral Indicator Switch then you will connect these two wires together (orn/blk and blk/wht). When this is done, the computer will think the vehicle is in park. Engine RPM may be limited by the computer!

Note: *If you do this, the computer will stop controlling the exhaust gas recirculation (EGR) solenoid. THIS WILL PREVENT THE SYSTEM FROM BEING STREET LEGAL.*

Note: *The EGR solenoid we have listed has been discontinued, the part # listed is for reference only. If this harness is being installed in a vehicle that must be emissions compliant, call Painless (800-423-9696) and we can provide you with a replacement part # and adapter pigtail.*

2. The recommended switch is a combination reverse light AND neutral safety switch. You may use it for these purposes AND for the needed computer signal if you wire it EXACTLY as shown in **Figure 6.2**. You will need to tape off and store the Blk/Wht wire in this case.
3. If you are going to use the recommended switch for the computer's benefit ONLY, then you will wire it as shown in **Figure 6.2**.
4. You may install your own switch. This switch must connect the Orn/Blk wire to ground ONLY when the car is in PARK. You may or may not want to use the Blk/Wht wire. The other end of the Blk/Wht wire is already connected to ground through the harness.

Note: *Not attaching the orn/blk wire to anything may turn on the check engine light.*

- E. The single purple wire is the wire that powers the lockup function on the transmission. If you ARE NOT using the lockup then you will tape off and store this wire. If you ARE using the transmission lockup function then you will have to install a vehicle speed sensor and a brake switch as described in **Paragraph 4.1.2**.

- F. If you are using the recommended brake switch then you will wire it according to **Figure 6.3**. The wire jumped to the back of the switch in the illustration is the wire that has power on it whether or not the brake is being applied. If you have installed your own switch then it must connect the single purple wire to power ONLY when the brakes are NOT being applied. If you are using a hydraulic brake switch see page 25 for proper wiring using a relay.

Caution: *Failure to wire this switch correctly will result in a dangerous situation on the vehicle.*

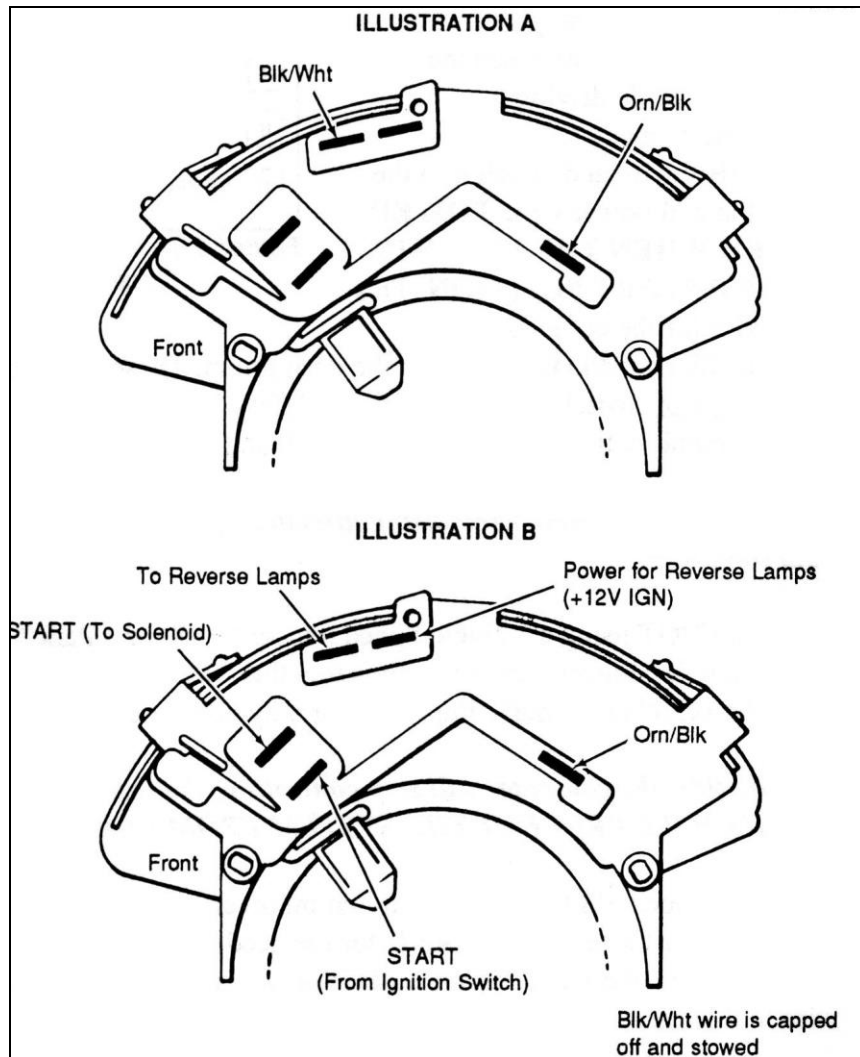

Figure 6.2 Neutral Safety Switch

- B. When installing a throttle body system using the manifold absolute pressure (MAP) sensor, the map sensor connection has been moved inside to clean up the engine compartment, but additional wire length has been added for optional engine compartment mounting. If you do remote mount the MAP sensor, you **MUST** use plastic or steel line, with the correct rubber elbows to ensure the sensor gets a correct vacuum signal. ***IMPORTANT!! The MAP sensor MUST be mounted with the vacuum port facing STRAIGHT DOWN!***

6.2.2 THROTTLE BODY INJECTION ENGINE GROUP

Note: If you have not already done so, separate the tail section from the engine group and place it out of the way.

- A. Locate the two Blk/Wht wires in the harness that end in a single ring terminal. Ground these wires to the engine. An intake manifold bolt is a good choice. These wires are the ground for the harness. The engine will not work if not attached properly.
- B. Starting at the rear of the engine, using **Figure 6.4**, **Table 6.2**, and the specific illustrations indicated in **Table 6.2**, begin attaching the connectors to their proper places and THEN secure the harness to the engine when ready.
- C. If you wish to use the power steering override switch (wire not furnished in kit) it must be wired IN-LINE along with the green/white wire marked a/c power in the harness with the power wire for the A/C compressor.

Note: If the throttle position sensor on your throttle body is different from the one illustrated in Figure 6.4, an adapter is in the kit.

6.2.3 Setting the Base Engine Timing

- A. To set base timing with this Painless harness you have to disconnect the set timing connector located inside the vehicle. It is approximately 6 inches from the main computer connectors. The timing connector is in line on the tan wire with the black stripe (Tan/Blk) and looks similar to the oxygen sensor connector.
- B. Once you have this disconnected, start the engine and set the base timing to 0 degrees.
- C. Shut the engine off. Plug the set timing connectors back together.
- D. Start the engine to check for proper operation.

Color	# of Positions In Connector	Labeled	Connect to:
Blk/Wht(1), Orn, Dk.Grn/Wht, Red, Gry or Tan/Wht	5	----	Fuel Pump Relay (Style 1) (This connector has the short red lead on it)
Blk/Wht,Orn,Dk.Grn/Wht, Gry or Tan/Wht	4	-----	Fuel Pump Relay (Style 2)
Lt.Grn, Gry, Pur or Blk	3	MAP ^{2,3}	Manifold Absolute Pressure Sensor
Red, Dk.Blu, Blk/Wht, Orn, Tan/Wht	5	MAF (P) ²	Mass Airflow Power Relay
Dk.Blu, Blk, 2x Orn	4	MAF (B) ²	Mass Airflow Burn off Relay
Blk, Brn, Pnk/Blk, Blu	5	ESC ^{2,3}	Electronic Spark Control Module

Notes:

1. On striped wires (example: Blk/Wht), the second color (stripe) may not be bold. Observe two-color wires closely.
2. Certain applications only.
3. Additional wire length has been added for optional engine compartment mounting.

Table 6.1 Sensor and Relay Connections

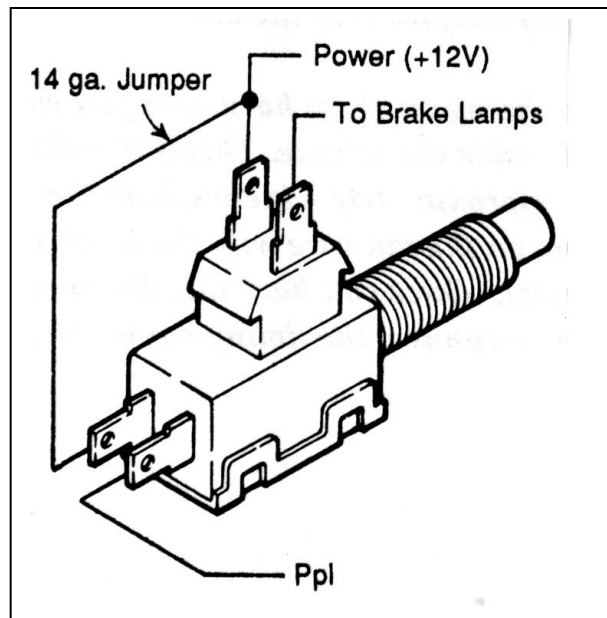

Figure 6.3 Brake Switch Connection

Wire Colors	# of Positions In Connector	Labeled	Connect to:
Pink/Black	-----	IGN	Crank/Run 12 Volt Source
Wht, Pur/Wht, Tan/Blk, Blk/Red	4	IGN	Distributor
Gry/Red, Pnk/Blk	2	EGR	Exhaust Gas Recirculation Valve Solenoid Figure 6.7
Lt.Blu/Wht, Lt.Blu/Blk Lt.Grn/Wht, Lt.Grn/Blk	4	IAC	Idle Air Control Valve Figure 6.7
Gry, Blk, Dk.Blu	3	TPS	Throttle Position Sensor Figure 6.7 ¹
Ylw, Blk	2	CTS	Coolant Temp Sensor Figure 6.7
Blu, Red	2 connectors	INJ	Fuel Injectors ²
Wht, Lt.Grn	2 positions each		
Red	-----	----	Starter Solenoid (Large Battery Terminal)
Pur/Wht	-----	----	Starter Solenoid (Inside Small Terminal)
Purple	1	OXY	Oxygen Sensor Figure 6.8
Dk.Blu	1	KNK	Knock Sensor Figure 6.9 ³
Dk.Grn/Wht	-----	-----	See NOTE 4

Notes:

1. If the throttle position sensor on your throttle body is different from the one illustrated in **Figure 6.7**, use the adapter provided in the kit.
2. It does not matter which connector goes to which injector. Once the connectors are in place, slide the grommet that is already on the wiring into the notch cut in the throttle body. Be careful not to let the air cleaner pinch any wires when you install it.
3. If you have headers you may have to relocate the knock sensor for proper clearance.
4. The Dk.Grn/Wht wire labeled A/C POWER should be spliced into the A/C compressor power wire, in a location close to the compressor itself. If you don't use this wire (for instance, you don't have A/C) tape and store it.

Table 6.2 Engine Section Connections

6.2.4 TAIL SECTION INSTALLATION

- A. Locate the tail section that you earlier separated from the engine group. Begin routing it towards the rear of the vehicle. Be sure to avoid all sharp edges, moving or hot parts, or anything else that may damage the harness.
- B. If you ARE using the lockup function, route the square 4-position connector to the transmission and attach it to the solenoid, **Figure 6.7**.
- C. If you ARE NOT using the lockup function, tape up the connector and store it in the harness.
- D. Take the long tan/white wire and route it to the fuel pump. This is the power wire for the fuel pump.
- E. Take the Brn wire and connect it to the Vehicle Speed Sensor as described on page 3 **Section 4.1.3**.

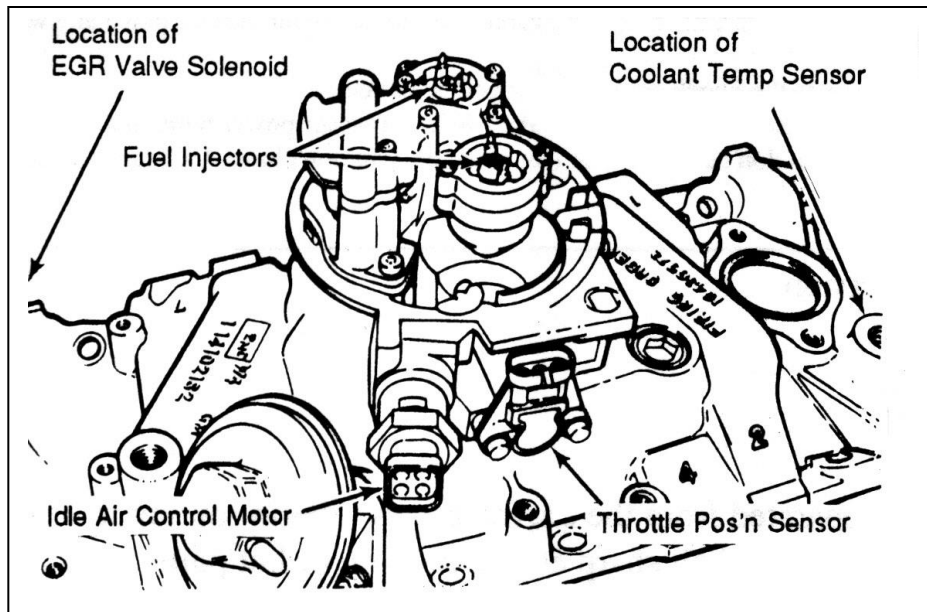

Figure 6.4 Throttle Body Injection Unit

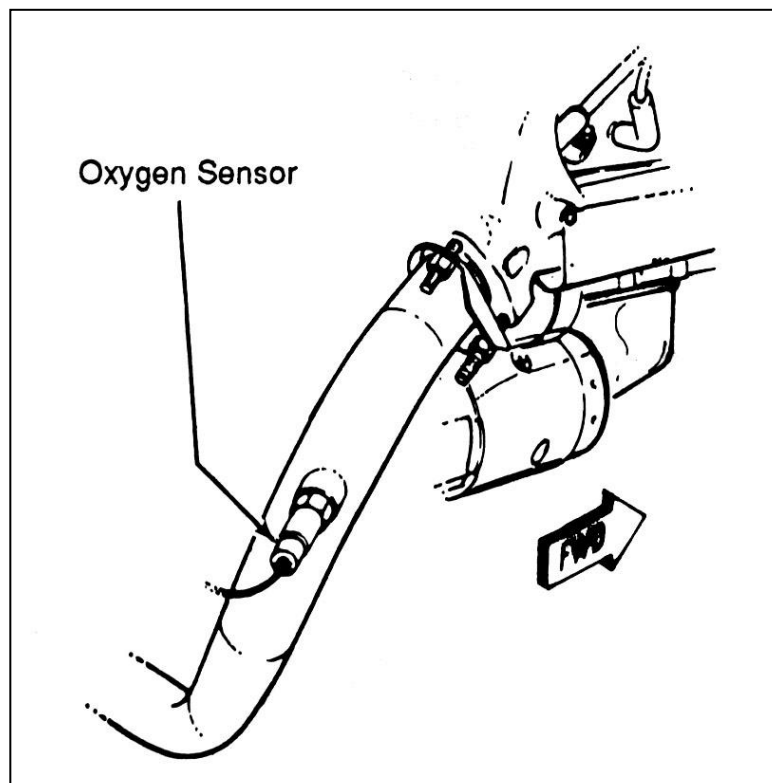

Figure 6.5 Oxygen Sensor

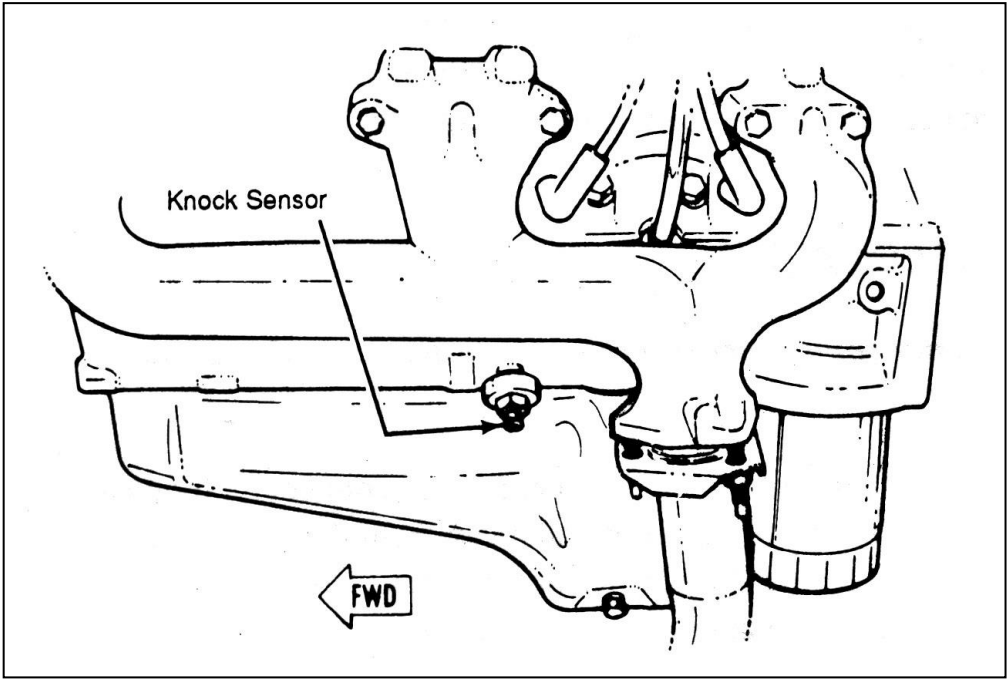

Figure 6.6 Knock Sensor

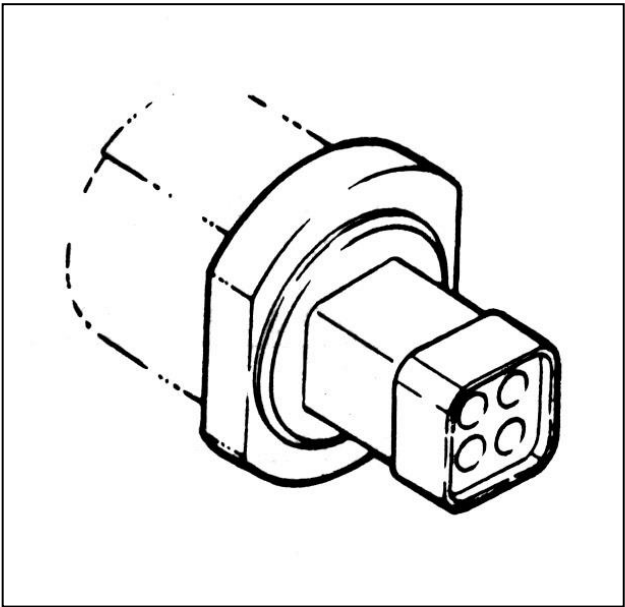

Figure 6.7 TCC Solenoid

7.0 TROUBLE SHOOTING INSTRUCTIONS

If you are having trouble with your engine running badly or not running at all, first perform basic trouble shooting (checking for faulty connections, spark, timing, fuel pressure, etc.) then see if the computer has stored a trouble code in its memory.

7.1 THE "CHECK ENGINE" LIGHT

Normally, the "check engine" light should come on when the ignition is initially turned on, and then turn off a few moments after the engine starts running. If it reappears, or stays on while the engine is running, the computer has detected a problem and a trouble code has been set.

7.1.1 The computer identifies particular trouble codes by flashing the "check engine" light in a certain way. The codes are read by counting the flashes:

- A. The first digit (the "tens" digit) of the code is flashed quickly, followed by a brief pause, then the second digit (or "ones" digit) is flashed, followed by a longer pause. For example, three (3) quick flashes followed by a brief pause followed by two (2) flashes indicates code 32.
- B. The code will repeat itself three (3) times. The next code, if any, will be displayed in the same manner.

Note: When you access the codes from the computer a code 12 (one flash followed by two flashes) will first be displayed. THIS DOES NOT INDICATE A PROBLEM. Code 12 will be flashed 3 times, followed by the particular trouble codes, if any. If the computer merely flashes code 12 there are no trouble codes stored. Code 12 means the engine is not running.

7.2 RETRIEVING TROUBLE CODES FROM THE COMPUTER

7.2.1 In order to retrieve the trouble codes stored in the computer, locate the Assembly Line Diagnostic Link (ALDL) connector (installed and connected in **Paragraph 6.2.1**). Turn the ignition on, BUT DO NOT START THE CAR. Connect a jumper wire from ALDL terminal "A" to terminal "B" (see **Figure 6.1**) and observe the "check engine" light.

7.2.2 After you have read any codes (remember the normal code 12), write them down for reference. Remove the jumper wire from the ALDL connector.

7.2.3 Take the codes one at a time and match them to the codes in **Table 9.1**. This will tell you in which circuit the computer has detected a problem.

Note: A code indicates a problem in a specific circuit, NOT THAT A PARTICULAR PART IS BAD.

7.2.4 Before taking more extensive corrective actions for any trouble code, make sure that all connections on the indicated circuit, **INCLUDING THE COMPUTER**, are clean and tight. Inspect the wiring in the circuit for any broken, shorted, or exposed wires. Finally, insure all ground wires are clean and secure.

7.2.5 If you are getting a code from your computer and need to clear the code, other than code 12, after you have replaced a part, readjusted a part, etc. You can do this by making sure the ignition is off and then disconnecting the negative battery cable for a minimum of two minutes. After the two minutes are up then you simply reconnect the negative battery cable and recheck the system for codes.

7.3 WHEN TO CALL PERFECT PERFORMANCE PRODUCTS' TECH LINE

7.3.1 These harness kits have been built with the highest regard to strict quality control. Before calling us please double-check all connections and perform normal basic trouble shooting (fuel pressure, timing, ignition system, etc.).

7.3.2 If you have any questions concerning the installation of this harness or are having trouble in general feel free to call the Painless Performance tech line at (800) 423-9696. Calls are answered from 8 AM to 5 PM CST, Monday through Friday, except holidays. Please leave a message if you are unable to reach us and we will return your call as soon as possible.

E-mail: painless@painlessperformance.com

Web: www.painlessperformance.com

CODE #	CIRCUIT AFFECTED	CODE #	CIRCUIT AFFECTED
13	Oxygen Sensor	35	Idle Air Control Circuit
14	Coolant Temp (high)	41 ²	Faulty or Incorrect Mem-Cal Chip
15	Coolant Temp (low)	42 ²	Electronic Spark Timing Circuit
21	Throttle Position Sensor	43	Electronic Spark Control Circuit
23	Manifold Air Temp (low)	44	Oxygen Sensor (lean reading) ⁵
24	Vehicle Speed Sensor ³	45	Oxygen Sensor (rich reading) ⁶
25	Manifold Air Temp (high)	46 ²	Vehicle Anti-Theft System
32	EGR Valve	51, 52, 55 ²	Faulty Mem-Cal, PROM, or Cal-Pak Chip
33	Mass Airflow or Manifold Absolute Pres. Sensor (high)	53	Charging System over-voltage
34	Mass Airflow or Manifold Absolute Pres. Sensor (low)	54	Insufficient Fuel Pump Voltage ⁷
 <i>Notes:</i>			
1.	A PROM, Mem-Cal or Cal-Pak chip that has not been fully seated or that has a bent contact may cause one or all of these codes to set.		
2.	If the Park/Neutral Indicator switch isn't wired correctly this code can set.		
3.	Early version TPI and TBI systems only.		
4.	Can be caused by a clogged fuel filter or a vacuum leak.		
5.	Can be caused by a clogged air filter.		
6.	Can be caused by a bad fuel pump relay.		

Table 9.1 Common Diagnostic Trouble Codes

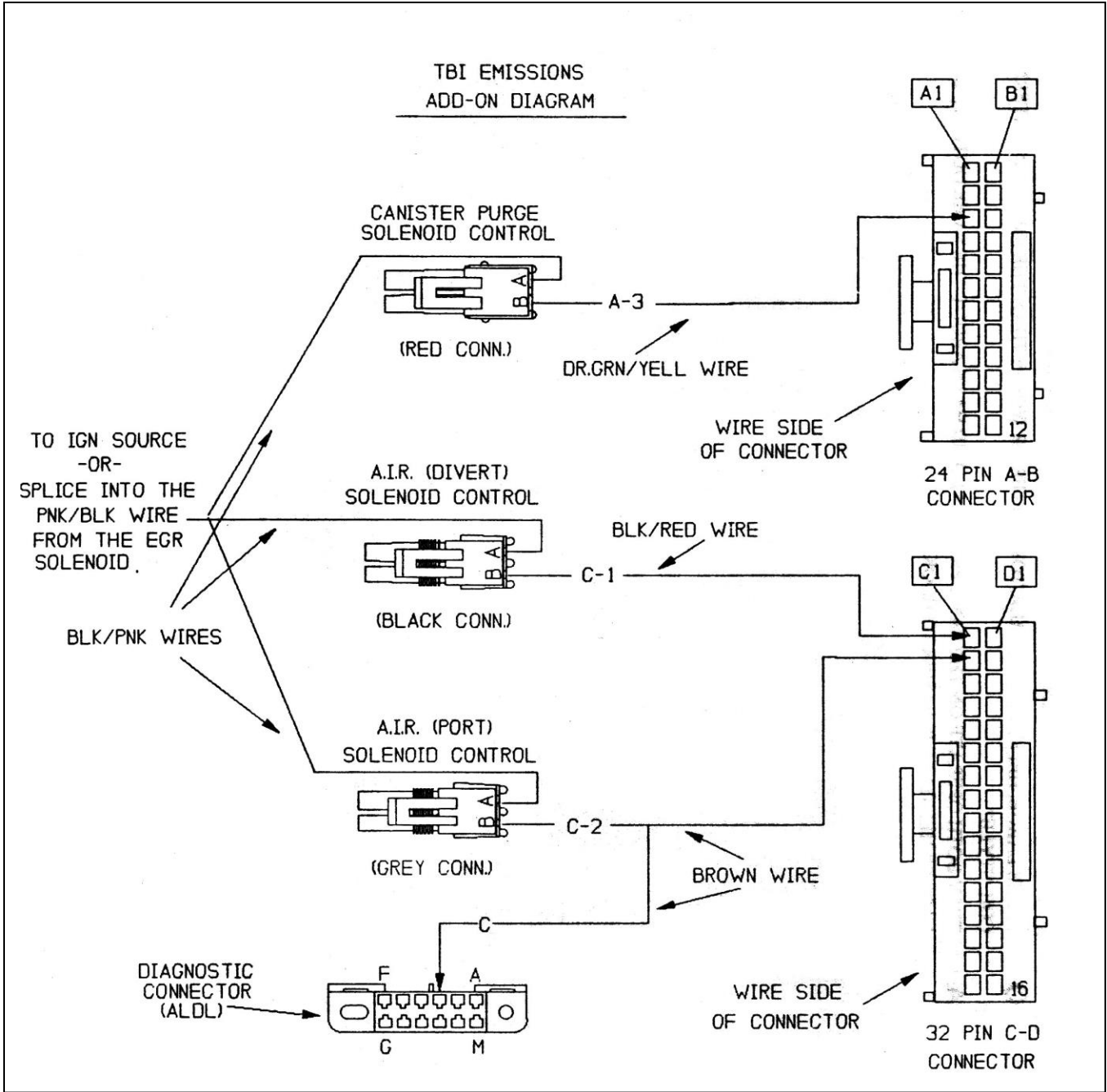

Diagram 1: TBI Emissions

8.0 ADD ON TBI EMISSIONS KIT

(For Part #60101 use Painless #60310 For Part #60201 use Painless #60311)

The emissions wires in this kit, if required, include: the wiring for the charcoal canister, the air port solenoid and the air pump diverter valve. (See Diagram 1, page 21).

STEP 1 - INSTALLATION OF CONNECTORS IN THE ENGINE COMPARTMENT

Install the following connectors into these locations:

The red connector with the Dk.Grn/Ylw and Blk/Pnk wires plugs into the charcoal canister mounted in the engine compartment.

The black connector with the Blk/Red and Blk/Pnk wires, plugs into the air port solenoid located on the back of the air pump.

The gray connector with the Brn and Blk/Pnk wires, plugs into the air pump diverter valve located behind the air pump.

STEP 2 - ROUTING THE WIRES

Route all of the wires from the front three connectors up to the coolant temperature sending unit located at the front of the engine next to the thermostat housing. Using tie wraps secure the wiring to the coolant temp sensor (black and yellow) wires all the way back to the computer located inside the vehicle. Be sure to leave enough slack for any possible engine movement.

Caution: Be careful routing the wires through the firewall to avoid damaging the terminals on the ends of the wires.

STEP 3 - ATTACHING THE B+ POWER WIRES

You will find that the three Blk/Pnk wires end near the back of the engine block. These wires should be spliced into the Pnk/Blk wire coming from the EGR solenoid connector. These wires can also be extended and connected to a 12 volt ignition only (switched) power source if you wish to do so.

STEP 4 - UNPLUGGING THE COMPUTER

Caution: Removing the computer connectors from the computer while the ignition is on will damage the computer!

First, making sure that the ignition is off, unplug the two computer connectors by pushing down on the blue retaining tab and then pulling straight out and away from the computer. Be careful not to damage the computer pins! Remove the blue secondary locks from the black computer connectors by releasing the retaining clips and pulling them out from the back (wire) side of the connectors.

STEP 5 - CONNECTING THE CHARCOAL CANISTER WIRE AT THE COMPUTER

Locate the 24-pin (the smaller of the two) computer connector. Using the attached Wiring diagram for reference, look on the wire side of the connector housing for the Corner marked "A-1". Once you have located this, count down the openings on the same side until you reach "A-3". You will insert the terminal on the Dk.Grn/Ylw wire (charcoal canister) into this opening, pushing in until the locking tang engages. ***Note: The terminal will only fit one way into the connector; do not try to force the terminal.***

STEP 6 - CONNECTING THE AIR DIVERTER WIRE AT THE COMPUTER

Locate the 36-pin (the larger of the two) computer connector. In the same manner as you did in Step 5, locate the "C-1" side. This is the opening you will insert the terminal on the Blk/Red wire into. (air pump diverter valve)

STEP 7 - CONNECTING THE AIR PORT SOLENOID WIRE AT THE COMPUTER

On the same connector, locate "C-2". This is the opening that you plug the terminal on the Brn wire (port solenoid) into, using the same procedure as in step 5 and 6.

Note: this wire has a second Brown wire spliced into it that should be set aside until Step 9.

STEP 8 - REPLACING THE COMPUTER CONNECTORS AT THE COMPUTER

Replace the secondary locks on both connectors. Be careful to line up the "fingers" on the locks with the connector openings. Once you have the secondary locks in place then you can reinstall the computer connectors into the computer.

Caution: Use care when reinstalling the connectors, to avoid damaging the computer pins.

STEP 9 - ATTACHING THE AIR PUMP DIAGNOSTIC WIRE AT THE ALDL

The Brn wire set aside in Step 6 goes to the ALDL connector (diagnostic plug). Route this Brn wire along the existing ALDL wiring until you come to the connector itself. The wire is inserted into the opening labeled "C" on the connector. (See Diagram 1, page 40).

Notes: Double check all routing making sure that there is enough slack to allow for any engine or other movement. Reinstall any grommets or other parts taken off.

Start and drive the vehicle for at least thirty minutes, then check for any trouble codes stored in the computer.

Brake Switch Connection

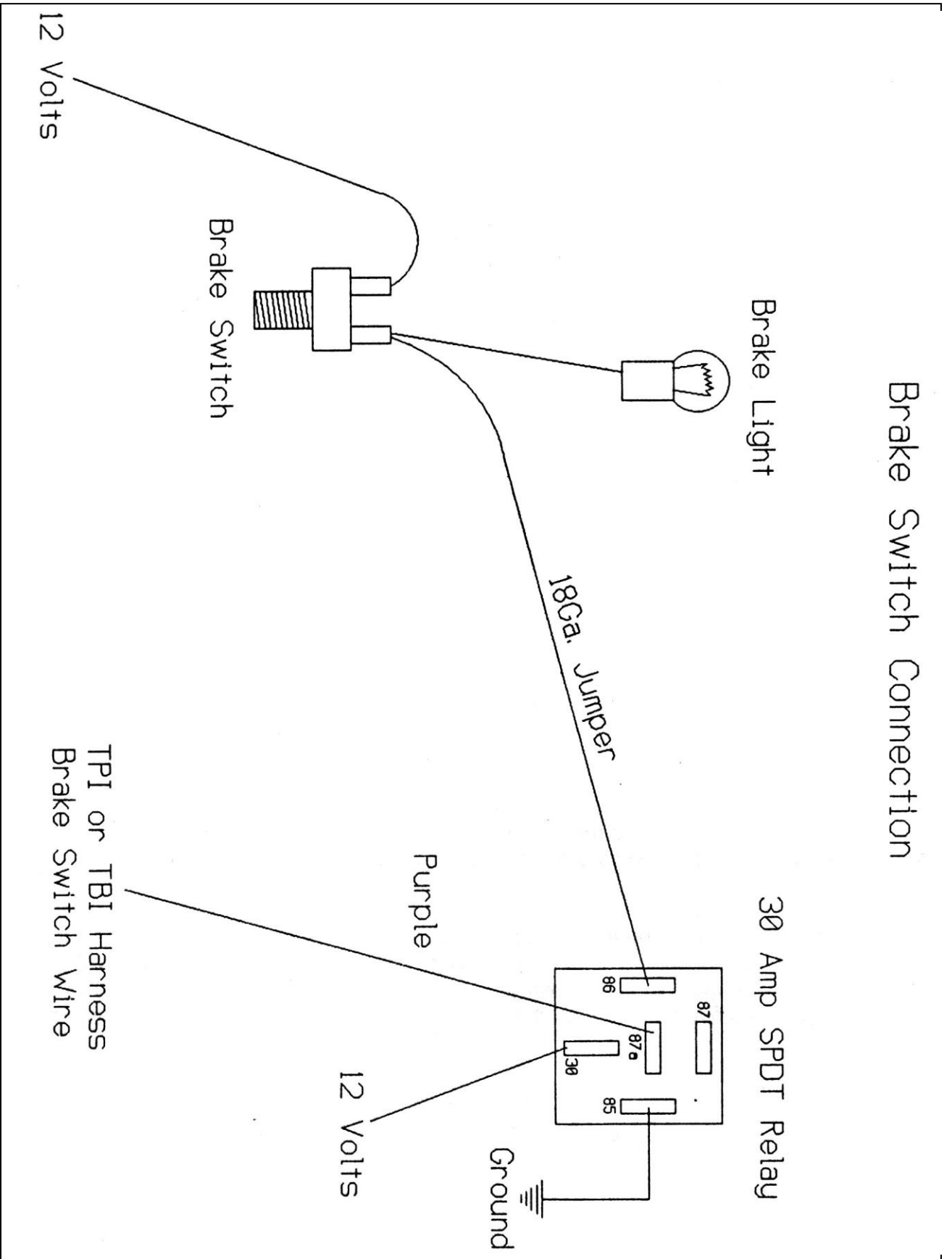

Diagram 2: Brake Switch Connection

Painless Performance Limited Warranty and Return Policy

Chassis harnesses and fuel injection harnesses are covered under a lifetime warranty.

All other products manufactured and/or sold by Painless Performance are warranted to the original purchaser to be free from defects in material and workmanship under normal use. Painless Performance will repair or replace defective products without charge during the first 12 months from the purchase date. No products will be considered for warranty without a copy of the purchase receipt showing the sellers name, address and date of purchase. You must return the product to the dealer you purchased it from to initiate warranty procedures.