



2501 Ludelle Street  
Fort Worth, Texas 76105  
817-244-6212 phone  
817-244-4024 fax  
800-423-9696 Tech

E-Mail: [painless@painlessperformance.com](mailto:painless@painlessperformance.com)  
Web: [www.painlessperformance.com](http://www.painlessperformance.com)

# 30003

## 18 CIRCUIT ATO FUSE CENTER INSTALLATION INSTRUCTIONS

THE 30003 IS A REPLACEMENT FUSE CENTER FOR INDIVIDUALS WANTING TO UPDATE THEIR CURRENT FUSE BLOCK OR INCREASE THEIR CURRENT ELECTRICAL CAPABILITIES. THE MAIN FUNCTION OF THE BLOCK IS TO PROVIDE FUSED POWER FOR UP TO EIGHTEEN CIRCUITS AND ACT AS A JUNCTION BLOCK FOR THE REMAINING CIRCUITS.

1. FIND A SUITABLE LOCATION UNDER THE DASH (POSSIBLY WHERE THE PREVIOUS FUSE BLOCK WAS LOCATED) AND ATTACH THE FUSE BLOCK MOUNTING BRACKET USING THE HOLES PROVIDED.
2. **IGN SW B+** ATTACH THE WIRE THAT PROVIDES POWER TO THE IGNITION SWITCH TO THIS TERMINAL. (RED WIRE) (12GA) SEE ILLUSTRATION 2
3. **IGN SW IGN** ATTACH THE WIRE FROM THE IGNITION SWITCH IGN TERMINAL TO THIS TERMINAL. (ORG WIRE) (12GA) SEE ILLUSTRATION 2
4. **COIL/DIST** ATTACH THE WIRE GOING TO THE IGNITION RESISTOR OR COIL TO THIS TERMINAL (PINK WIRE) (14GA) SEE **NOTE A** BELOW.
5. **IGN SW COIL** ATTACH THE WIRE FROM THE IGNITION SWITCH IGN TERMINAL TO THIS TERMINAL. (PINK WIRE) (14GA) SEE **NOTE A** BELOW AND ILLUSTRATION 2.
6. **FUEL PUMP B+** ATTACH THE WIRE GOING TO THE ELECTRIC FUEL PUMP TO THIS TERMINAL. (YLW/WHT WIRE) (16GA)
7. **EL FAN B+** ATTACH THE WIRE GOING TO THE ELECTRIC ENGINE COOLING FAN RELAY OR THE ELECTRIC ENGINE COOLING FAN SWITCH TO THIS TERMINAL. (GRY/WHT WIRE) (18GA) SEE **NOTE C**.

8. **ALT IGN B+** ATTACH THE WIRE GOING TO THE IGNITION SWITCHED TERMINAL OF THE ALTERNATOR REGULATOR (INTERNAL OR EXTERNAL) TO THIS TERMINAL. THIS IS THE EXCITER WIRE FOR THE ALTERNATOR REGULATOR. (WHITE WIRE) (14GA)
9. **ALT OUTPUT** ATTACH THE WIRE FROM THE BATTERY POST ON THE BACK OF THE ALTERNATOR TO THIS TERMINAL. (RED WIRE) (12GA)  
**CAUTION:** IF YOU HAVE AN ALTERNATOR WITH AN OUTPUT GREATER THAN **65 AMPS**, YOU MUST RUN AN ADDITIONAL WIRE FROM THE ALTERNATOR OUTPUT POST TO THE BATTERY OR STARTER SOLENOID.
10. **IGN SW ACCY** ATTACH THE WIRE FROM THE IGNITION SWITCH ACCESSORY TERMINAL TO THIS TERMINAL. THIS WIRE SUPPLIES POWER TO THE ACCESSORY SIDE OF THE FUSE BLOCK. (BROWN WIRE) (12GA) SEE ILLUSTRATION 2
11. **DASH B+** ATTACH THE WIRE USED FOR POWER TO THE DASH INSTRUMENTS, WARNING LIGHTS, ETC. TO THIS TERMINAL. (RED/WHT WIRE) (18GA)
12. **LIGHT SW B1** ATTACH THE WIRE TO POWER UP THE HEAD LIGHT SWITCH TO THIS TERMINAL. (RED/BLK WIRE) (12GA)
13. **LIGHT SW B2** ATTACH THE WIRE FROM THE SECOND PART OF THE HEAD LIGHT SWITCH TO THIS TERMINAL IF NEEDED, TO POWER UP THE SECOND PART OF THE HEAD LIGHT SWITCH. (ORG WIRE) (14GA) **NOTE:** SOME HEADLIGHT SWITCHES DO NOT NEED THIS WIRE. SEE ILLUSTRATION 1.
14. **HAZ SW B+** ATTACH THE WIRE TO POWER UP THE HAZARD SWITCH TO THIS TERMINAL. (THIS CIRCUIT HAS A FLASHER IN IT) (BROWN WIRE)(16GA)
15. **TURN SW B+** ATTACH THE POWER WIRE GOING TO THE TURN SIGNAL SWITCH IN THE STEERING COLUMN TO THIS TERMINAL.(THIS CIRCUIT HAS A FLASHER IN IT.) (PURPLE WIRE) (16GA)
17. **HORN SW** ATTACH THE WIRE COMING FROM THE HORN SWITCH(IN THE STEERING COLUMN OR FROM AN EXTERNAL BUTTON) TO THIS TERMINAL. (BLACK WIRE) (18GA) THIS WIRE, WHEN GROUNDED, ACTIVATES THE HORN RELAY.
18. **TO HORN** ATTACH THE WIRE GOING TO THE HORN ITSELF TO THIS TERMINAL.(GREEN WIRE) )(14GA)
19. **WIPER B+** ATTACH THE POWER WIRE FROM THE WINDSHIELD WIPER SWITCH OR WIPER MOTOR TO THIS TERMINAL.(BLUE WIRE) (16GA)

20. **A/C HEATER B+** ATTACH THE WIRE FROM THE A/C-HEATER CONTROL SWITCH POWER TO THIS TERMINAL.(BLK/WHT WIRE) (14GA)
21. **STOP SW B+** ATTACH THE POWER WIRE GOING TO THE BRAKE LIGHT SWITCH TO THIS TERMINAL. (ORANGE WIRE) (14GA)
22. **DR LOCKS B+** ATTACH THE WIRE FROM THE DOOR LOCKS TO THIS TERMINAL.(YLW/BLK WIRE) (14GA)
23. **PWR WND B+** ATTACH THE WIRE TO POWER THE ELECTRIC WINDOWS TO THIS TERMINAL. (YELLOW WIRE) (14GA)
24. **BACKUP SW B+** ATTACH THE WIRE FROM THE BACKUP SWITCH TO THIS TERMINAL. (LT GREEN WIRE) (18 GA)
25. **RADIO B+** ATTACH THE WIRE GOING TO THE RADIO FOR CONSTANT POWER TO THIS TERMINAL. (RED WIRE) (18GA)
26. **RADIO B+ SW** ATTACH THE WIRE GOING TO THE RADIO FOR SWITCHED POWER TO THIS TERMINAL. (RED/BLK WIRE) (18GA)
27. **CIG LTR B+** ATTACH THE WIRE FROM THE CIGARETTE LIGHTER TO THIS TERMINAL. (TAN WIRE) (14 GA)
28. **DOME LT B+** ATTACH THE WIRE PROVIDING POWER TO THE DOME LIGHT OR TRUNK LIGHT TO THIS TERMINAL. (WHITE WIRE) (18 GA)
29. **OPT ACCY B+** THIS TERMINAL IS FOR THE USE OF ANY ACCESSORY THAT REQUIRES NO MORE THAN **5 AMPS** NOTE: THIS TERMINAL HAS POWER ONLY WHEN THE IGNITION IS ON. (ORG/BLK WIRE) (18 GA).
30. **BAT FEED** ATTACH THE WIRE GOING TO THE POSITIVE BATTERY POST OR STARTER SOLENOID TO THIS TERMINAL.THIS WIRE PROVIDES POWER FOR THE ENTIRE SYSTEM. (LARGE RED WIRE) (10GA)

**NOTE: THE USE OF A 50 AMP MAXIFUSE AT THE BATTERY OR STARTER END OF THIS CIRCUIT IS STRONGLY RECOMMENDED. PAINLESS PERFORMANCE OFFERS A 50 AMP MAXIFUSE, HOLDER AND COVER AS PART #80101.**

**CAUTION:** Testing The System

*Use a small (10 amp or less) battery charger to power up the vehicle for circuit testing. If there is a problem anywhere, the battery charger's low amperage and internal circuit breaker will provide circuit protection.*

- NOTE A:** THE WIRE NORMALLY GOING FROM THE IGNITION SWITCH IGNITION TERMINAL TO THE COIL IGNITION RESISTOR HAS BEEN CUT IN HALF TO GO THROUGH THE FUSE IN THE FUSE BLOCK. THIS IS DONE FOR TWO REASONS; IT PROVIDES A FUSED IGNITION CIRCUIT FOR ELECTRONIC FUEL INJECTION SYSTEMS AND A THEFT DETERRENT. BY REMOVING THE FUSE YOU WILL DISABLE THE IGNITION CIRCUIT.
- NOTE B:** THE WIRE COLOR CODING NOTED IN EACH STEP IS THE COLOR OF WIRES AT THE FUSE BLOCK. COLOR CODING OF YOUR VEHICLES WIRES MAY NOT BE THE SAME.
- NOTE C:** ATTACH THE ACTIVATION WIRE FROM THE FAN RELAY TO THIS TERMINAL. THE FAN RELAY WILL HAVE A SEPARATE WIRE THAT WILL BE CONNECTED TO THE BATTERY FOR THE FAN MAIN POWER.
- B+** MEANS BATTERY POWER
- (14GA)** THESE SYMBOLS, AFTER EACH INDIVIDUAL INSTRUCTION, INDICATE THE RECOMMENDED WIRE SIZE (MAY NOT BE ORIGINAL SIZE) OF WIRE TO USE BETWEEN THE FUSE BLOCK & THE COMPONENT.

ILLUSTRATION #1

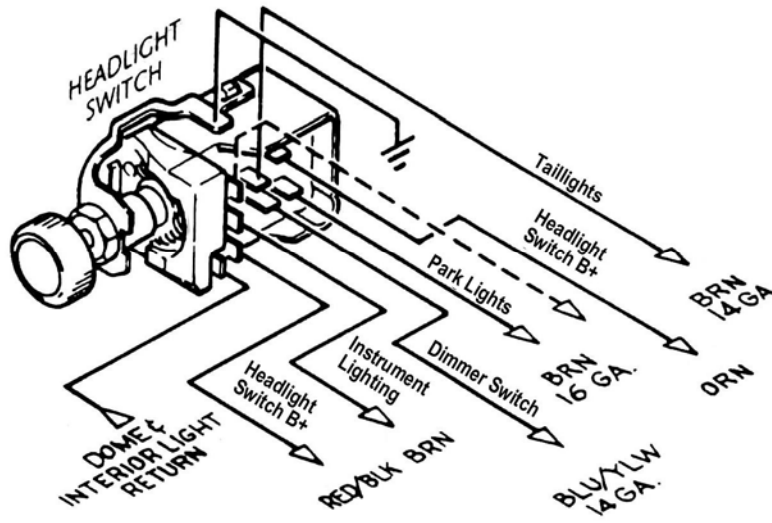
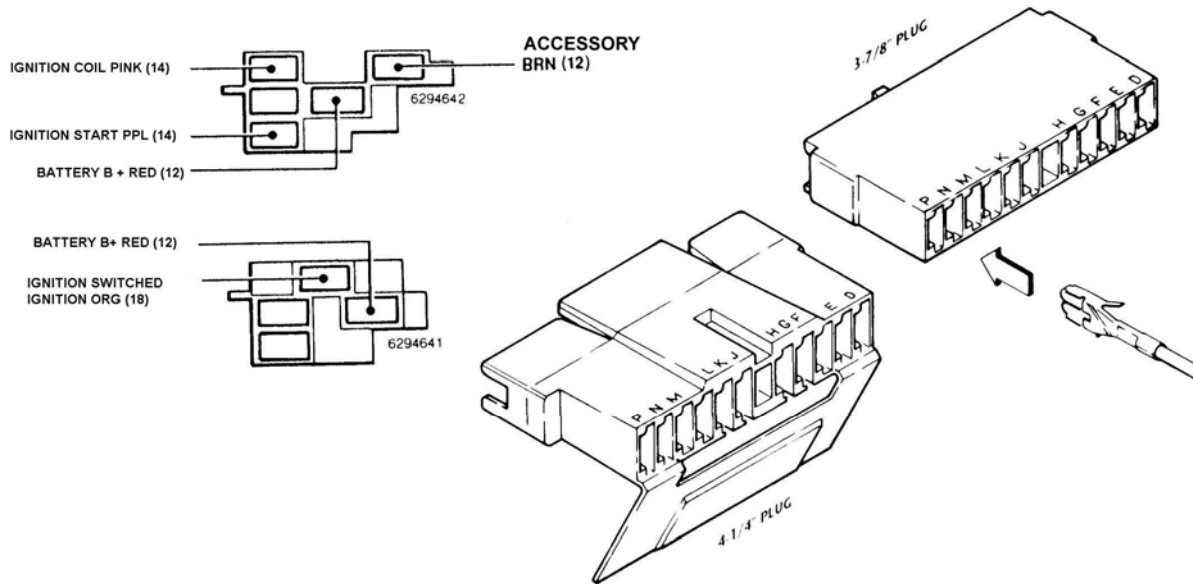
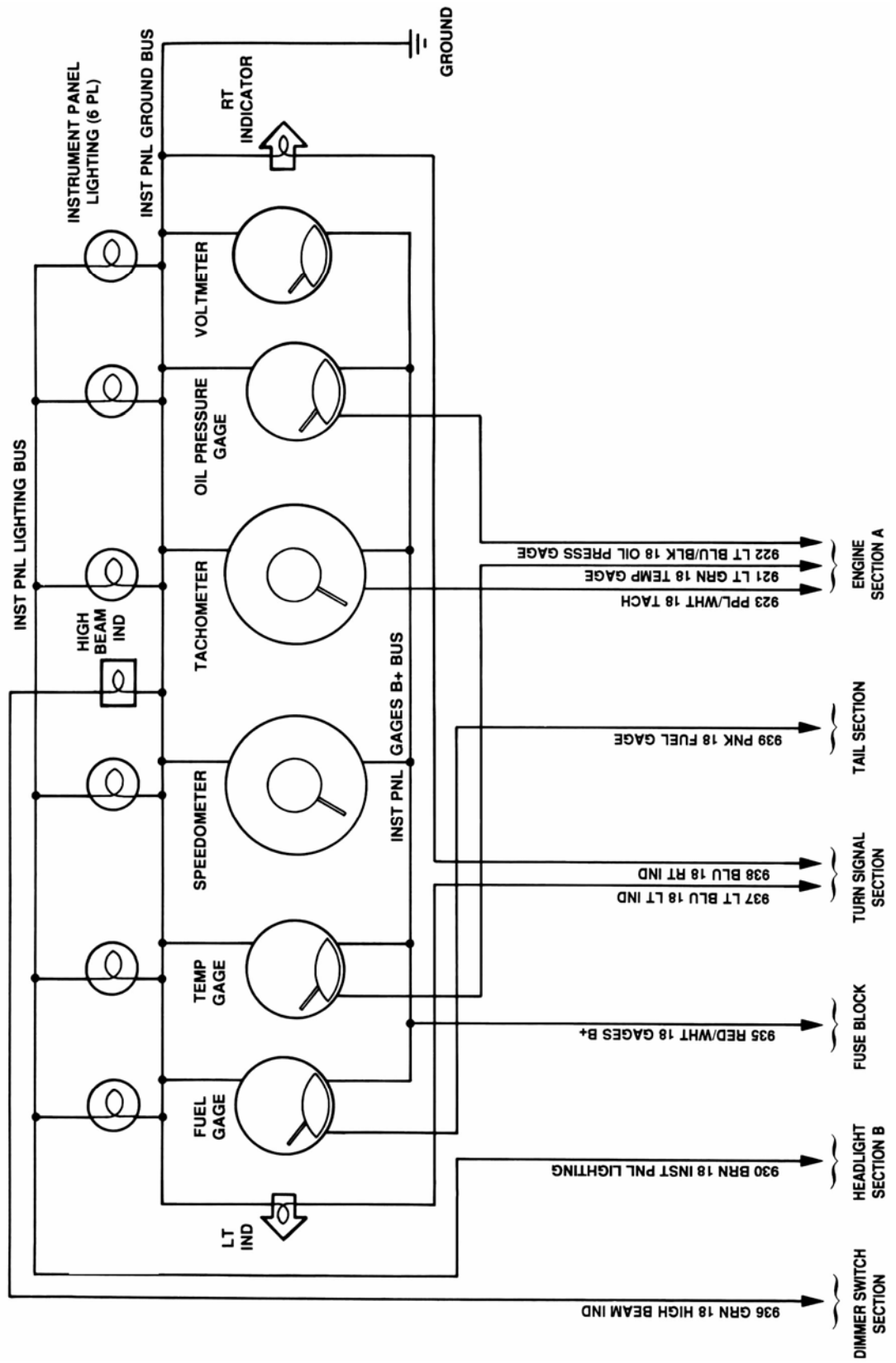
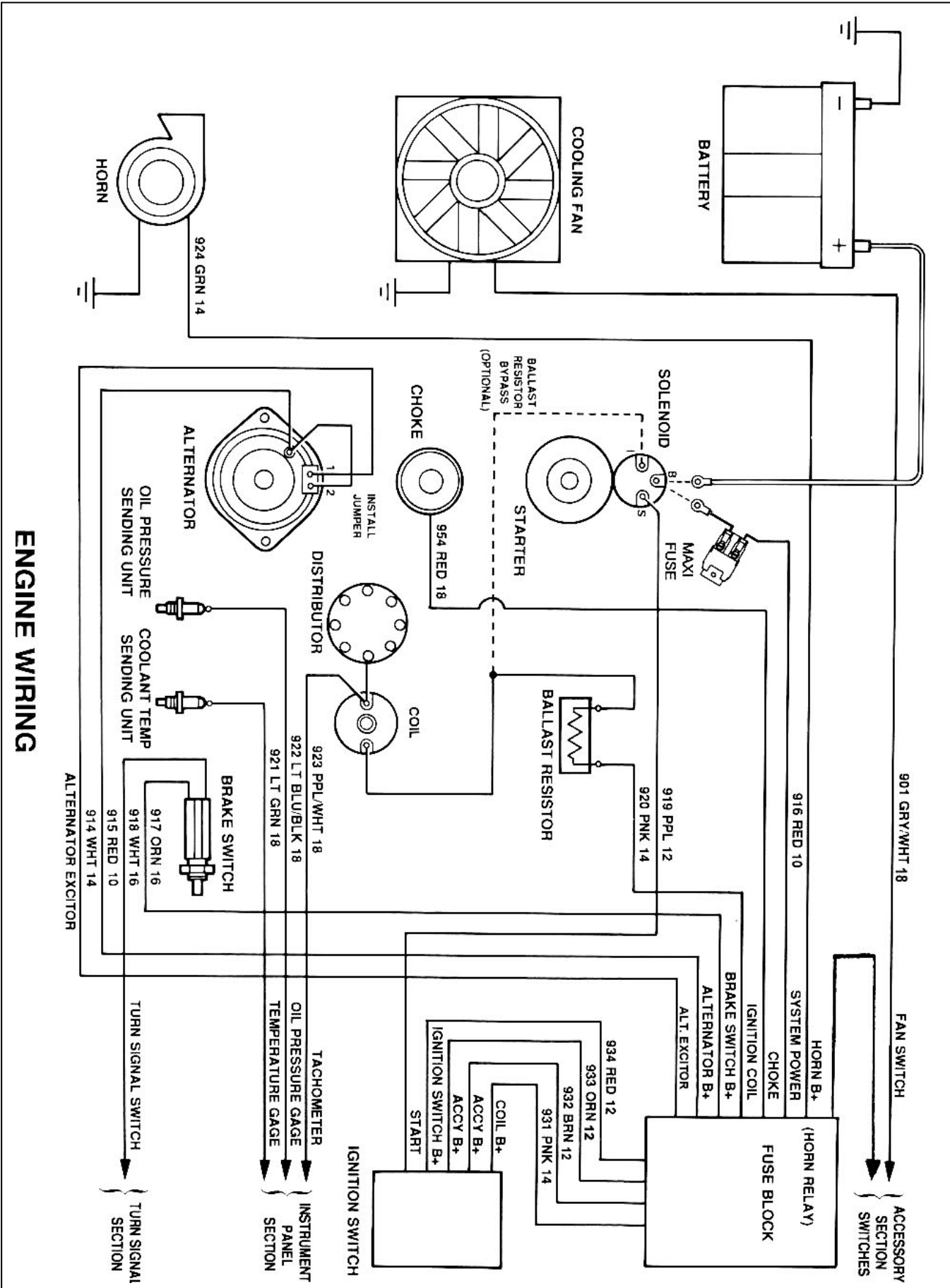

ILLUSTRATION #2



# INSTRUMENT PANEL SECTION WIRING





## **Painless Performance Limited Warranty and Return Policy**

Chassis harnesses and fuel injection harnesses are covered under a lifetime warranty. All other products manufactured and/or sold by Painless Performance are warranted to the original purchaser to be free from defects in material and workmanship under normal use. Painless Performance will repair or replace defective products without charge during the first 12 months from the purchase date. No products will be considered for warranty without a copy of the purchase receipt showing the sellers name, address and date of purchase. You must return the product to the dealer you purchased it from to initiate warranty procedures.