

Installation Instructions for Water Methanol Stage 2

Installation- Mechanical Step 1 Reservoir Install

Install 1/8" NPT – 1/4" OD elbow into 3/8-1/8 NPT reducer bushing using GOOP sealant (Right). Install this assembled fitting with GOOP sealant into the bottom of the reservoir. Note location options for the included low level warning light sensor. The nozzle, not the reservoir, should be the highest point in the system.

Optional: The factory windshield washer reservoir can be used as the reservoir for your system, using optional part number 15050.

- Drill 9/16" hole in desired bulkhead location.
- Remove one nut from bulkhead and turn the remaining nut until it is at the very end.
- Feed red tubing through the drilled hole and up and out of the top of the reservoir.
- Attach tubing to the bulkhead on the side opposite the nut.
- Pull the tubing through the bulkhead hole until the bulkhead seats against the inside of the reservoir.
- Apply GOOP sealant (included) around bulkhead.
- Slide the nut you had previously removed up onto the tube and thread onto bulkhead.
- While pulling firmly on the red tubing, tighten the outer nut using a 17mm socket (only needs to be hand tight). A ratchet is not needed.
- Once sealant has set, fill reservoir with water and check for leaks.

Step 2 Pump Install

Mount the pump so the inlet is positioned at the lowest point of the reservoir or lower. Pump can be mounted horizontally or vertically using the supplied screws and washers. Ensure that no sharp bends in the high pressure tube occur near the pump. Sharp bends can cause stress on the inlet and outlet ports of the pump, causing leaks. Trim tube with a utility knife or razor blade, making sure to eliminate any burrs or kinks on the end. Insert firmly into the pump about 1/2 inch through the light grey locking collar. Note the arrows indicating flow direction on the top of the pump. To remove the hose, gently and evenly push the light grey locking collar into the head unit of the pump, then pull on the hose gently.

Measure the distance from the reservoir outlet to the pump inlet. Cut the 1/4" red tubing using utility knife. Make cuts are as square as possible.

Ensure there are no kinks in the tubing and insert tubing into quick disconnects at pump and reservoir until fully seated. Keep the pump within 2 feet of the reservoir.



Step 3 Nozzle Selection

Nozzle sizing is a function of horsepower, which approximates the engine airflow, and boost, which approximates intake charge heat.

Recommended starting points:

250 - 350 RWHP: 175 ml/min nozzle.
350 - 475 RWHP: 375 ml/min nozzle
475 - 600 RWHP 625 ml/min nozzle

TECH TIP: Seal the nozzle into the nozzle holder using the included GOOP sealant. Using a sealant that is not permanent will allow for nozzle changes during tuning. Simply remove the nozzle, clean the threads, and reinstall using sealant.

Assemble desired nozzle into nozzle holder using GOOP sealant. The end of the nozzle with the fine mesh screen is to be inserted into the nozzle holder. Torque 1/2 turn past finger tight. Do not use Teflon sealants on NX fittings.



Correct



Incorrect

NOTE: If nozzle is mounted lower than the reservoir, a Solenoid Upgrade (#15055) must be used to prevent draining.

Step 4 Nozzle Mounting

The nozzle assembly should be installed 90° to the direction of airflow. On round intake tubes, this is 360° around the tube meaning the nozzle can be mounted in any direction. This will ensure maximum cooling as the nozzle sprays in a cone pattern. Be sure that the nozzle tip is flush with the inside wall of the tube, or even projecting into it slightly to ensure no interference in the spray pattern. Make sure the nozzle is the highest point in the system as well.

Drill and tap (11/32" pre-drill, 1/8"-27 NPT tap) air inlet tube as close as possible to throttle body/throttle plate.

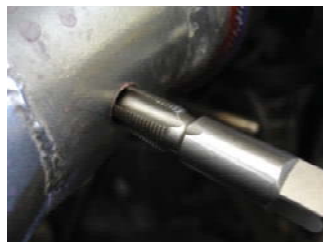

The nozzle is mounted using its external 1/8 NPT threads. Tighten the nozzle and nozzle holder assembly one half turn past finger tight using GOOP to seal the threads.

Carb Plates are available for 4150 and 4500 style carburetors.

You can mount the nozzle in a plastic or rubber air inlet tube using a Nozzle Mounting Adapter (#15056). Weld-in aluminum (#15057) and steel (#15058) bungs are also available.

TECH TIP: The recommended nozzle mounting point is before the throttle body/ throttle plate. If you mount the nozzle after the throttle body/throttle plate (including use of a carb spacer plate) or below the reservoir, a Solenoid Upgrade (#15055) must be used to prevent siphoning at idle or gravity feed.

Step 5 Nozzle Connection

Measure the distance from the pump outlet to the nozzle holder. Cut the 1/4" tubing using utility knife. Make cuts are as square as possible.

Ensure there are no kinks in the tubing and insert tubing into quick disconnects until fully seated. Gently pull on tubing to ensure a good connection.



Use tie wraps to help route tubing and to ensure it doesn't contact moving or hot parts in the engine compartment. Have tubing connect to quick connect fittings at shallow angles. Having an immediate sharp bend may unseat the tubing from the internal o-ring and create a leak.

Continual insertion and removal from quick connect fittings will mar the end of the tubing. Over time the internal gripping teeth may lose their hold of the tubing which may create a leak. If this occurs simply remove the tubing and make a fresh cut using a razor blade.

Installation - Electrical Variable Controller Installation

Attach the controller to secure location with easy access in engine bay or passenger compartment. The VC series controllers are designed to withstand engine bay conditions, but should not be mounted directly to the engine block. Often a location inside the passenger cabin is ideal as long as wires can be routed safely through the firewall. Be sure to mount the controller with easy access to the adjustment dials.



CAUTION: Disconnect the negative battery terminal while connecting wires to prevent electrical fire or damage to controller.

- Connect BLACK wire to a good ground location.
- Connect GREEN wire to Pump RED power wire.
- Connect RED wire to 12 volt key on source. When selecting a 12 volt key-on source, try to find a dedicated circuit fused for 10-15 amps.
- Connect YELLOW wire to the MAF sensor signal output wire. Pontiac GTOs for instance use a brown wire with white stripe.

Setting MAF Sensor Type

The VC-MAF controller is designed to work with four different types of vehicle MAF sensors. A four position switch located inside the VC-MAF allows the selection of the MAF sensor type. The 4th switch engages a traditional 0-5V MAF mode. The VC-MAF reads the selection switch on power up to determine the mode of operation. The switch selection can be changed at any time, but power to the VC-MAF needs to be cycled before the new selection will be used.

To access the MAF selector switch, remove the plastic plug located under the wire harness connector on the front of the VC-MAF. The default setting is all switches but 4 (right) in the OFF or UP position. This selects a 0-5 volt output type of MAF sensor.

ON	OFF	OFF	OFF	Mitsubishi/Dodge (DSM etc)
OFF	ON	OFF	OFF	1993 and Older GM (Low HZ MAFs)
OFF	OFF	ON	OFF	1994 and Newer GM (High HZ MAFs, VW 2.0T etc.)
OFF	OFF	OFF	ON	0-5V Hotwire MAFs (Ford, Toyota, 1.8T VW etc.)

Note: Only one switch can be in the ON or DOWN position at a time. If more then one switch is in the ON position, the VC-MAF will not control injection properly.

Variable Controller Tuning

- Adjust the START level first by turning dial clockwise to the 12:00 position. This sets the MAF sensor output required to activate the injection system.
- Next, adjust FULL level to the air flow sensors max voltage or HZ output.
- Note - over lapping the settings, where the FULL dial is lower then START, will result in max injection at the onset point.

- Road test vehicle and adjust FULL dial until a smooth power curve is felt with no misfiring. Often the full dial can be set lower than the max output of the MAF for more cooling. If any bucking or bogging is experienced, increase the full point until it is eliminated. If bucking is felt at the onset of injection, increase the start point.

Controller Operation Example

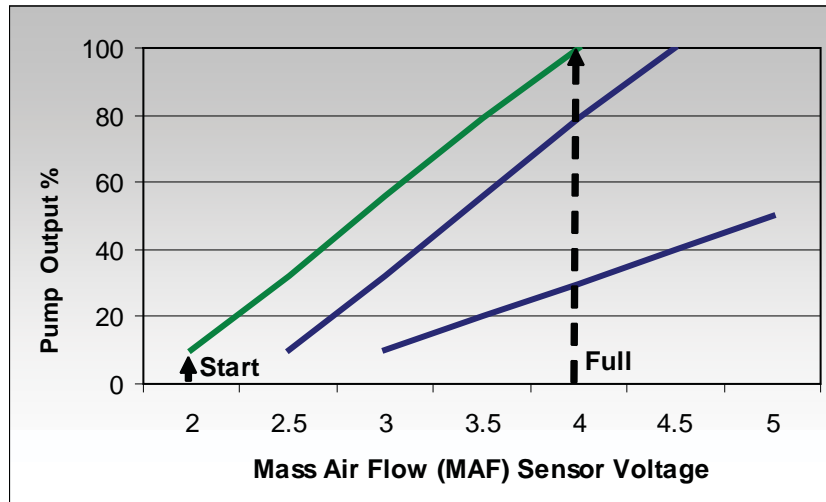

For setting 1, left, the chart shows the Start dial at 2 volts and the Full dial at 4 volts. At 2 volts from the MAF, the pump will operate at 10%. At 4 volts from the MAF, the pump will deliver 100% of injection pressure.

For MAF voltage readings between the Start and Full settings, the controller will linearly adjust the pump output as shown on the graph. Note the chart on the controller itself. This shows what settings are associated with particular voltages and HZ values for the various modes available.

Example:

In most applications, the start dial should initially be set at the 12:00 position, so that typical airflow levels in normal driving do not trigger injection needlessly. The full dial should be all the way to the clockwise position. Start tuning by carefully trying lower start point settings. If bogging is experienced at the onset of injection, move the start dial back up a small amount. Then try lower and lower points for the full setting. If bogging is experienced as injection ramps up, turn the full point back up to a safe level. The engine should run with no bogging or miss-fires. Be sure to make small changes and then test them each time to avoid any drastic differences in injection.

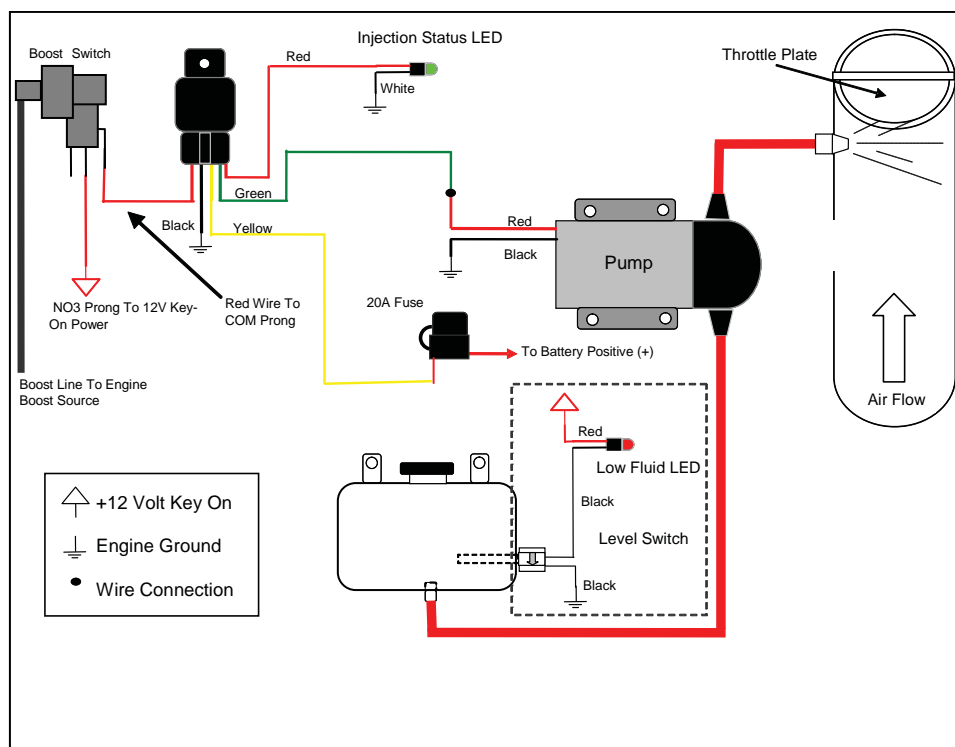

Nozzle Identification Chart:

Nozzle Number	Nozzle Size	Nozzle Number	Nozzle Size
1	60 ml/min	4	225 ml/min
2	100 ml/min	5	375 ml/min
3	175 ml/min	6	625 ml/min

Testing the System

Note: for best results, prime pump before use To clear air from the pump and insure that the system is primed:

- Fill reservoir with water approx ¼ full.
- Remove tubing from nozzle (or solenoid if solenoid used in-line between pump and nozzle) and run tube into separate container.
- Apply 12 VDC to red pump wire for approximately 5 seconds or until fluid flow is consistent.
- Pump is now primed. Reconnect tubing from pump outlet to nozzle (or solenoid).

Step 1 Test Pump and Mechanical System

Turn key to ON position. Bypass the pressure switch by touching a wire between the two poles on the switch. Pump should activate, green LED should go on, and fluid level in tank should go down. It is recommended to also check the nozzle spray pattern while following this procedure. Also check for leaks.

If pump goes on and fluid level doesn't go down, there is an obstruction in the tube or nozzle.

Activation of the pump in 1-5 second intervals will purge air from the system after install. This can be accomplished in initial use.



Step 2 Test LED vs. Pump On

Apply a 12v source to pole #87 of relay (single red wire, not red/green wire). Pump should activate and LED should go on. Check LED ground and wiring if no activation. If wiring and ground check out okay, check LED with 12v source.

Initial Tuning

#20001 Set Boost Switch Activation Point

At the factory setting, the boost switch will start injection at about 10 psig boost. Adjusting the set screw clockwise will increase the boost pressure needed to activate injection. Turning the adjustment screw counter-clockwise will decrease it. 1 full turn counter-clockwise will decrease the injection point by 1-2 psig. Typical injection onset points are at ½ of maximum boost.

TECH TIP: Introducing water/methanol before ½ of maximum boost pressure could result in quenched combustion and engine misfire.

Tuning Quick Reference

The power potential of the system is realized through increased boost and/or timing. The large gains on octane and cooling provided by the system make this possible, even on standard pump fuel.

The Water Methanol system adds an alternate fuel source as well as significantly cools combustion. With the Water Methanol system, one does not need to cool combustion with overly rich air/fuel ratios. To minimize combustion quench, you should start with an air to fuel ratio of 12.0-12.5:1.

Injecting water/methanol lower than 3300-3500 RPM could result in combustion quench. All vehicles are different. If the engine bogs or loses power, then it is coming on too early, the quantity is too much, or there is not enough methanol in the mixture (50/50 water/methanol recommended).

Maintenance – Remove nozzle(s) and clean screen filters once per year using carb cleaner.

The Water Methanol system has been designed to operate with high concentrations of methanol. Oil or other additives are not required for system lubrication, and can cause damage to the system.

Contaminants in the fluid such as dirt can damage the system. Ensure that dirt and debris do not fall into the tank.

Do not use Teflon tape or paste to seal connections. These sealers are not as effective as the Goop sealant provided and can break down over time, clogging components.

Fluid Level Switch Instructions

- Locate desired level switch mounting position. Suggested placement is 1/5 of max reservoir height.
- Carefully drill side of reservoir using 13/16" bit. A step bit is recommended for best drilling results. Hole must be free of nicks or shavings for proper sealing.
- Remove rubber seal from level switch. Insert seal into reservoir until fully seated. Goop can be used around the edges of the hole.
- Lubricate exterior of level switch with water and insert into seal until fully seated. Position level switch so GT symbol is at six o'clock position.
- Wait 30 minutes for Goop to cure, then test for leaks. With fluid level above level switch, float should be angled up. With fluid level below level switch, float should be in horizontal position.

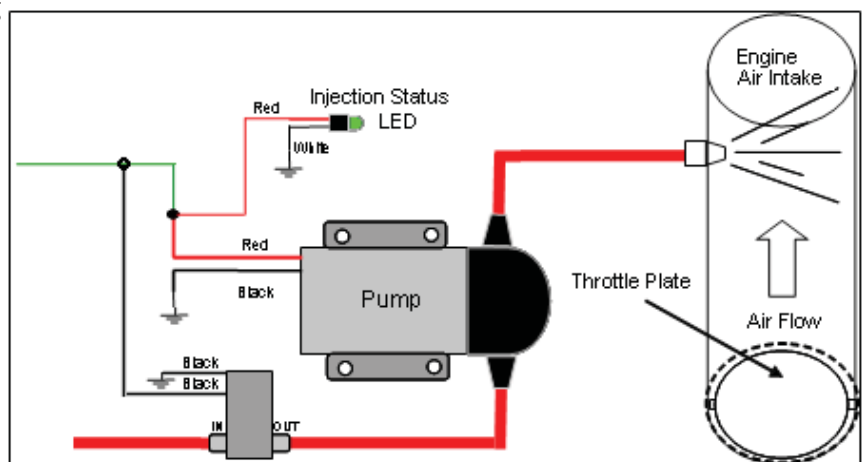

- Connect one black wire from level switch to ground.
- Connect other black wire from level switch to white wire from LED.
- Connect red wire from LED to +12 volt key on power source.

Solenoid Upgrade (optional)

The optional Solenoid Upgrade (#15055) is required if the nozzle is to be installed after the intake throttle plate (as shown), or the fluid reservoir is mounted higher than the nozzle. It is highly recommended for trunk-mount reservoirs.

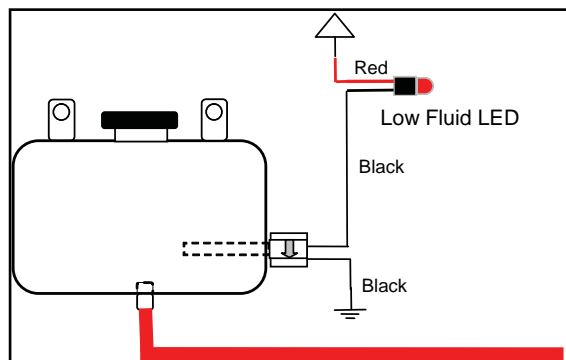

Finger thread the two 1/8" NPT quick connect fittings into ports labeled (2 or IN) and (1 or OUT) on the solenoid. Tighten an additional half turn past finger tight.

Note: Solenoid must be installed Pre-pump to ensure correct operation.

Cut high pressure line at location solenoid is to be installed. Insert ends of cut line into quick connect fittings of solenoid. The port labeled (2 or IN) is the inlet and the port labeled (1 or OUT) is the outlet. Gently pull on line to check secure connection. If line pulls out, re-insert farther into fitting to engage locking clips. If high pressure line removal is required, firmly press in metal fitting ring to disengage locking clips while pulling hose from fitting.

Connect one of the BLACK wires from solenoid to the RED positive pump wire or the WHITE wire from the controller. Note that connecting the wire to any other power source other than the pump/controller wire will result in improper operation of solenoid. Connect the second BLACK wire to a secure chassis ground location.

RIGHTS RESERVED

As our technology expands, we may find it necessary from time to time to make changes in some of the items offered in our catalog. Nitrous Express reserves the right to make, without notice, changes in design, material and specifications or to make product changes without liability.

PRINTING ERRORS

Every effort has been made to proof all copy prior to printing. However, we do not accept responsibility for typographical errors either in prices or content.

MAXIMUM LIABILITY

The maximum liability of Nitrous Express in connection with this warranty shall not under any circumstances exceed the contract price of the product claimed to be defective.