



P/N A5059-1-SNOS

## FACTORY FUEL INJECTION SYSTEM

Kit Numbers: 05117NOS, 05121NOS, 05132NOS, 05144NOS,  
05150NOS, 05204NOS, 05208NOS, 05215NOS, 05342NOS, & 05348NOS



## OWNER'S MANUAL

**CONGRATULATIONS** on purchasing your NOS Nitrous Oxide Injection System. Your system is composed of the highest quality components available. It should provide many miles of trouble-free performance when used correctly. If you have any questions regarding the performance of your system, call NOS Technical Service at 1-866-GOHOLLEY.

**NOTICE: Installation of Nitrous Oxide Systems Inc. products signifies that you have read this document and have agreed to the terms stated within.**

It is the purchaser's responsibility to follow all installation instruction guidelines and safety procedures supplied with the product as it is received by the purchaser to determine the compatibility of the product with the vehicle or the device the purchaser intends to install the product on.

Nitrous Oxide Systems Inc. assumes no responsibility for damages occurring from accident, misuse, abuse, improper installation, improper operation, lack of reasonable care, or all previously stated reasons resulting from incompatibility with other manufacturers' products.

Nitrous Oxide Systems Inc. assumes no responsibility or liability for damages incurred by the use of products manufactured or sold by Nitrous Oxide Systems Inc. on vehicles used for competition or racing.

Nitrous Oxide Systems Inc. neither recommends nor condones the use of products manufactured or sold by Nitrous Oxide Systems Inc. on vehicles, which may be driven on public roads or highways, and assumes no responsibility for damages incurred by such use.

NOS nitrous oxide is legal for use in most states when used in accordance with state and local traffic laws. NOS does not recommend or condone the use of its products in illegal racing activities.

NOS has not pursued California Air Research Board (CARB) exemptions for these kits, hence, they are not legal for use on pollution-controlled vehicles in California. A correctly installed NOS nitrous system should not alter the emission control performance of your vehicle under standard EPA test cycle conditions.

**NOTICE: The NOS Factory Fuel Injection System Kit is not intended for use on hatchback type vehicles without the use of NOS part numbers 16160NOS (External Aluminum Blow-Down Tube) and 16166NOS (Racer Safety Pressure Relief Cap).**

## HAZARDS DEFINED

This manual presents step-by-step instructions that describe the process of installing your NOS Nitrous Oxide Injection System. These procedures provide a framework for installation and operation of this kit. Parts are referenced by name and number to avoid confusion. Within the instructions, you are advised of potential hazards, pitfalls, and problems to avoid. The following examples explain the various hazard levels:

**WARNING! Failure to comply with instructions may result in injury or death.**

**CAUTION! Failure to comply with instructions may result in damage to equipment.**

**NOTE:** This information is important, needs to be emphasized, and is set apart from the rest of the text.

**HINT:** These special instructions provide a handy work tip.

## NITROUS OXIDE INJECTION SYSTEM SAFETY TIPS

### WARNINGS

- **Do not attempt to start the engine if the nitrous has been injected while the engine was not running. Disconnect the coil wire and turn the engine over with the throttle wide open for several revolutions before attempting to start. Failure to do so can result in extreme engine damage.**
- **Never permit oil, grease, or any other readily combustible substances to come in contact with cylinders, valves, solenoids, hoses, and fittings. Oil and certain gases (such as oxygen and nitrous oxide) may combine to produce a highly flammable condition.**
- **Never interchange nitrous and fuel solenoids. Failure to follow these simple instructions can result in extreme engine damage and/or personal injury.**
- **Never drop or violently strike the bottle. Doing so may result in an explosive bottle failure.**
- **Never change pressure settings of safety relief valve on the nitrous bottle valve. Increasing the safety relief valve pressure settings may create an explosive bottle hazard.**
- **Identify the gas content by the NOS label on the bottle before using. If the bottle is not identified to show the gas contained, return the bottle to the supplier.**
- **Do not deface or remove any markings, which are on the nitrous bottle.**
- **Nitrous bottle valves should always be closed when the system is not being used.**
- **Notify the supplier of any condition, which might have permitted any foreign matter to enter the valve or bottle.**
- **Keep the valves closed on all empty bottles to prevent accidental contamination.**
- **After storage, open the nitrous bottle valve for an instant to clear the opening of any possible dust or dirt.**
- **It is important that all threads on the valves and solenoids are properly mated. Never force connections that do not fit properly.**

# TABLE OF CONTENTS

What is Nitrous Oxide?.....	4
Do's and Don'ts of Nitrous Oxide.....	4
Chapter 1 Introduction to Your NOS Nitrous Oxide Kit.....	4
1.1 General Information.....	4
1.2 System Requirements.....	5
1.3 Kit Components.....	6
Chapter 2 Kit Installation.....	7
2.1 Bottle Mounting Instructions.....	7
2.1.1 Street Vehicles.....	7
2.1.2 Racing Vehicles.....	8
2.2 Bottle Orientation.....	8
2.3 Bottle Installation.....	8
2.4 Fogger Nozzle Installation.....	9
2.5 Solenoid Mounting.....	10
2.6 Solenoid/Fogger Nozzle Hose Connection.....	11
2.7 Nitrous Feed Line Mounting.....	11
2.8 Fuel Supply Connection.....	11
2.8.1 Fuel Systems with Fuel Logs.....	11
2.8.2 Fuel Systems without Fuel Logs.....	12
2.9 Electrical System Requirements.....	14
Chapter 3 Baseline Tuning Suggestions.....	15
Chapter 4 Preparing for Operation.....	15
Chapter 5 Advanced Tuning for Maximum Power.....	16
5.1 Determining Optimum Nitrous/Fuel Jetting.....	16
5.1 Determining Optimum Ignition Timing.....	17
Chapter 6 Routine Maintenance.....	17
6.1 Nitrous Solenoid Filter.....	17
6.2 Nitrous Solenoid Plunger.....	18
6.2.1 General Information.....	18
6.2.2 Nitrous Solenoid Plunger Disassembly & Inspection.....	18
Appendix A Troubleshooting Guide.....	20
Nitrous Oxide Accessories.....	22

# LIST OF FIGURES AND TABLES

Figure 1 Factory Fuel Injection System Kit Components.....	7
Figure 2 Nitrous Bottle Siphon Tube Orientation.....	8
Figure 3 Nitrous Bottle Mounting Orientation.....	8
Figure 4 Factory Fuel Injection System Exploded View.....	9
Figure 5 Fogger Nozzle Installation Cut-Away.....	10
Figures 6 & 7 Typical Fuel Logs.....	12
Figure 8 Fuel Filter/Banjo Fitting.....	13
Figure 9 Schematic of "Drilled Out" Banjo Fitting.....	13
Figure 10 Wiring Schematic.....	13
Figure 11 Microswitch Mounting.....	14
Figure 12 Spark Plug Condition.....	16
Figure 13 Exploded View of Typical Solenoid.....	19
Table 1 Jetting Combinations.....	5
Table 2 0-3.0L Factory Fuel Injection System Parts List.....	6
Table 3 0-3.0L Factory Fuel Injection System Jetting Map.....	15

## WHAT IS NITROUS OXIDE?

### NITROUS OXIDE...

...Is a cryogenic gas composed of nitrogen and oxygen molecules

...Is 36% oxygen by weight

...Is non-flammable by itself

...Is stored as a compressed liquid

...Exists in two grades—U.S.P. and Nitrous Plus:

- U.S.P. is medical grade nitrous oxide; its common use is dental and veterinary anesthesia. It is also commonly used as a propellant in canned whipped cream. U.S.P. is not available to the public.
- Nitrous Plus differs from U.S.P. in that it contains trace amounts of sulphur dioxide added to prevent substance abuse. Nitrous Plus is intended for automotive applications and is available for sale to the public

In automotive applications, Nitrous Plus and fuel are injected into the engine's intake manifold, which produces the following results:

- Lowers engine intake air temperature, producing a dense inlet charge.
- Increases the oxygen content of the inlet charge (air is only 22 percent oxygen by weight).
- Increases the rate at which combustion occurs in the engine's cylinders.

## Do's and Don'ts of Nitrous Oxide

### Do's

- Read all instructions before attempting to install your NOS nitrous system.
- Make sure your fuel delivery system is adequate for the nitrous jetting you have chosen. Inadequate fuel pressure or flow will result in engine damage.
- Use 14 gauge (minimum) wire when installing electrical system components.
- Use high-quality connections at all electrical joints.
- Use Teflon-based paste on pipe style fittings.
- Make sure your engine and related components (ignition, carburetor, and driveline) are in proper working condition.
- If nitrous is accidentally injected into the engine when it is not running, remove the engine coil wire, open the throttle, and crank the engine 10 to 15 seconds before starting. Failure to do so can result in an explosive engine failure.**
- Use your NOS nitrous system only at wide-open throttle and at engine speeds above 3000 RPM.**
- Install a proper engine to chassis ground. Failure to do so may result in an explosive failure of the main nitrous supply line.**
- Use a high-quality fuel, as suggested in Chapter 3, Baseline Tuning Suggestions.

### Don'ts

- Engage your nitrous system with the engine off. Severe engine damage can occur.
- Modify NOS nitrous systems (if you need a non-stock item, call NOS Technical Service for assistance)
- Overtighten AN type fittings.
- Use Teflon Tape on any pipe threads. Pieces of Teflon tape can break loose and become lodged in nitrous or fuel solenoids or solenoid filters. Debris lodged in a nitrous or fuel solenoid can cause catastrophic engine failure.



- Use sealant of any kind on AN type fittings.
- Allow nitrous pressure to exceed 1100 psi. Excessive pressure can cause swelling or in extreme cases failure of the nitrous solenoid plunger. Solenoid plungers are designed so that pressure-induced failures will prevent the valve from operating. No leakage should occur with this type of failure.
- Inhale nitrous oxide. Death due to suffocation can occur.**
- Allow nitrous oxide to come in contact with skin. Severe frostbite can occur.**
- Use octane boosters that contain methanol. Fuel solenoid failure may occur, producing severe engine damage.

## Chapter 1 Introduction to your NOS Nitrous Oxide Kit

### 1.1 General Information

Kit Numbers 05117NOS, 05121NOS, 05132NOS, 05144NOS, & 05150NOS are intended for late model passenger cars displacing 3.0L or less, which are equipped with factory fuel injection.

Kit Numbers 05204NOS, 05208NOS, 05215NOS, 05244NOS, 05342NOS, & 05348NOS are intended for late model, factory fuel injected, turbo-charged passenger cars displacing 3.0L or less.

These kits are intended primarily for applications in which “Dry Manifold” technology systems cannot be used, due to the vehicle’s fuel system design.

**NOTE:** This nitrous oxide injection system injects a mixture of nitrous oxide and fuel upstream of the throttle body. If the instructions are not carefully followed, poor mixture distribution can occur, resulting in variations of air to fuel ratio from cylinder to cylinder. In extreme cases, intake manifold backfires can occur, if the instructions are not followed exactly.

These kits have been designed for safety and smoothness of operation. Nitrous oxide is injected into the engine only when the following conditions are met:

- Bottle valve is opened.
- System is armed.
- Engine is at wide-open throttle.

Horsepower and torque increases due to these kits will vary with engine displacement and modifications. Approximate power increase estimates can be made based upon the massflow of nitrous oxide into the engine. The following table is provided to allow you to estimate the power increase you can expect for your application. NOS **strongly** suggests that an upper limit of about 40% to 50% increase in power output from your stock engine. Exceeding this can result in premature engine failure.

**Table 1 Jetting Combinations**

Kits	Nitrous/Fuel Jetting	Approximate Power Increase (BHP)	Approximate N <sub>2</sub> O Consumption Rate
Kits 05121NOS-05348NOS	34/18*	40 HP	.50lbs./10 sec.
	37/22	50 HP	.60lbs./10 sec.
	39/24*	60 HP	.75lbs./10 sec.
	41/26*	70 HP	.85lbs./10 sec.
	43/28*	80 HP	1.00lbs./10 sec.
	46/30*	100 HP	1.25lbs./10 sec.
Kit 05117NOS	28/18	60 HP	.75lbs./10 sec.
	30/20*	70 HP	.85lbs./10 sec.
	32/22*	80 HP	1.00lbs./10 sec.

\*Not included in kits. **Note:** Kit 05117NOS features 2 nozzles.

**NOTE:** If this system is being installed on a vehicle other than which it was originally intended for, please refer to Chapter 4, “Preparing for Operation”, and Chapter 3, “Baseline Tuning Suggestions”, for information on jet selection.

Driveability, fuel economy, and exhaust emissions should not be affected under normal (part throttle) conditions.

## 1.2 System Requirements

When used correctly, these kits will work with stock internal engine components. **To ensure proper performance and engine life with all Factory Fuel Injection kits, the following is an absolute must:**

### Manual Transmissions

If the vehicle is to be exposed to severe operating conditions, such as drag strip usage, the standard clutch should be replaced with a high performance unit.

### Automatic Transmissions

If the vehicle is to be exposed to severe operating conditions, such as drag strip usage, a reputable high performance transmission shop should service the automatic transmission.

### 1.3 Kit Components

Before beginning the installation of your NOS kit, compare the components in your kit with those shown in Figure 1 and listed in Table 2. If any components are missing, please contact NOS Technical Support at 1-866-GOHOLLEY.

**Table 2 0-3.0L Factory Fuel Injection Parts List**

Item	Description	Quantity	NOS P/N
(1)	4AN Bottle Nut Adapter	1	16220NOS
(2)	Teflon Bottle Nut Washer	1	16210NOS
(3)	#10 N <sub>2</sub> O Bottle	1	14745NOS
(4)	#10 Bottle Bracket Set	1	14125NOS
(5)	Fogger Nozzle	1***	13700BNOS
(6)	1/16" NPT Tap	1	15990NOS
(7)	Fogger Nozzle Adapter	1***	13715-SNOS
(8)	Fogger Nozzle Adapter Nut	1***	13713-SNOS
(9)	Nitrous Solenoid	1	16020NOS
(10)	1/8" NPT x 4AN N <sub>2</sub> O Filter	1	15570NOS
(11)	2 ft. 3AN Hose (Blue)	1***	15060NOS
(12)	Fuel Solenoid	1	16080NOS
(13)	90° 4AN Swivel (Male/Female)	1	17535NOS
(14)	2 ft. 3AN Hose (Red)	1***	15061NOS
(15)	Solenoid Mounting Bracket w/ screws	1	16505NOS
(16)	Flare Jets	2***	*
(17)	14 ft. 4AN Hose (Blue)	1	15295NOS
(18)	1/16" NPT x 4AN Fitting (Brass)	1	17945NOS
(19)	Microswitch**	1	15640NOS
(20)	Arming Switch	1	15602NOS
(21)	Wiring Relay—30 AMP	1	15618NOS
(22)	Harness for Wiring Relay with 15 AMP Fuse	1	15604-SNOS
(23)	2 ft. 4AN 1/8" NPT Hose (Red)	1	15230-2-SNOS

\*Varies with kit.

\*\*Includes brackets and screws.

\*\*\*Kits for vehicles with dual throttle bodies include 2 of these items.

Red and blue "TEE" fittings for the solenoid outlet ports are also included.

Figure 1 Factory Fuel Injection System Kit Components

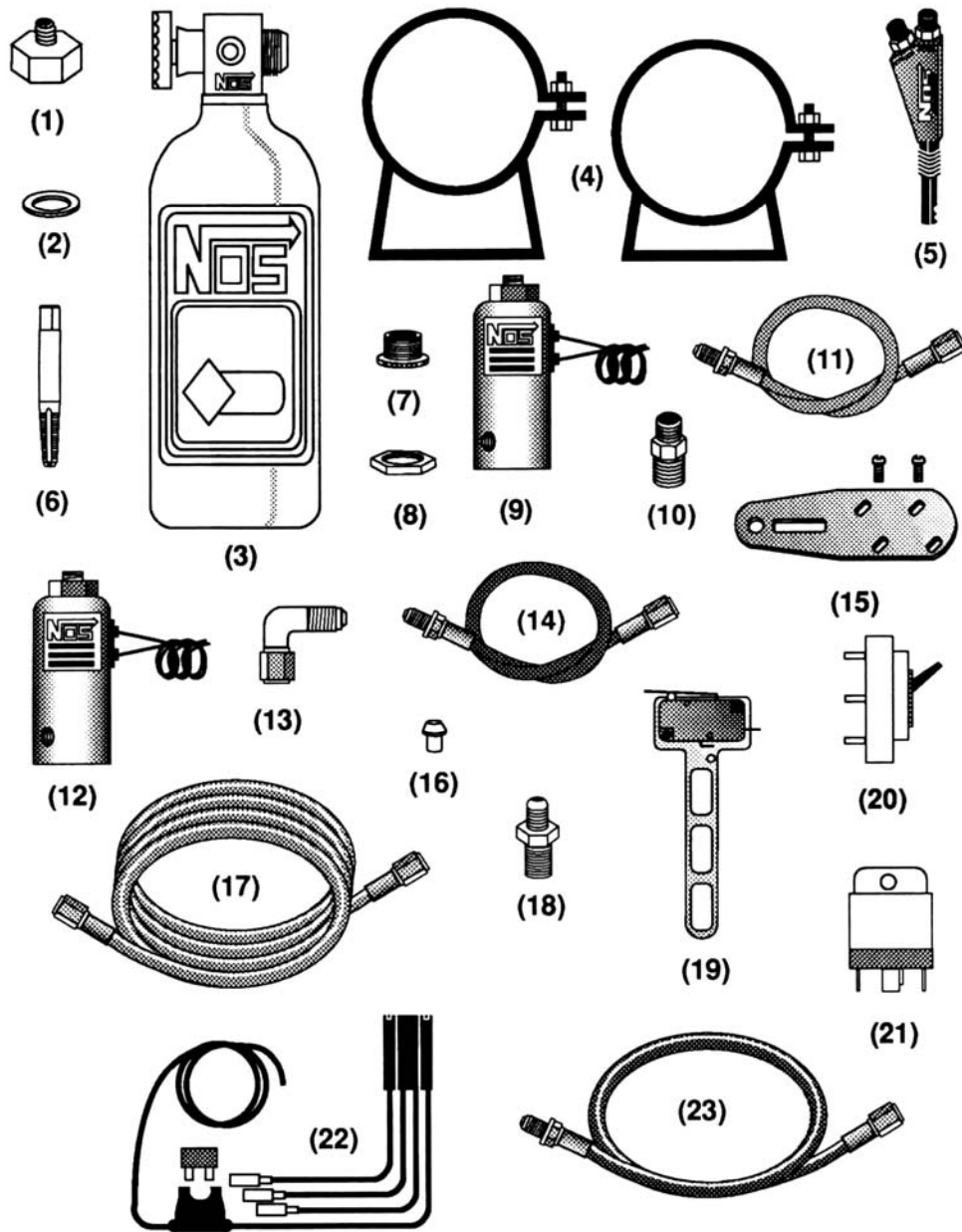

## Chapter 2 Kit Installation

### 2.1 Bottle Mounting Instructions

**NOTE:** Disconnect the battery ground before beginning installation.

#### 2.1.1 Street Vehicles

Accurate calibration of your NOS nitrous system depends on the bottle remaining at a stable temperature. Mount the bottle away from heat sources, such as the engine compartment or exhaust system, and away from windows, where the bottle is exposed to direct sunlight.

NOS recommends that the bottle be environmentally separated from the driver's compartment. Because hatchback-type vehicles generally do not have a firewall between the trunk area and the driver's compartment, the safety pressure relief cap should be replaced with P/N 16166NOS and P/N 16160NOS should be added. P/N 16160NOS is an aluminum blow-down tube (a -8 neoprene-line braided hose can be substituted). The blow-down tube should be routed to the exterior of the vehicle (preferably under the vehicle). This procedure will prevent filling the driver's compartment with a cloud of nitrous oxide, if the safety pressure relief cap should happen to rupture for any reason.

## 2.1.2 Racing Vehicles

Before mounting a nitrous bottle in a racing vehicle intended for use in sanctioned events, check with the sanctioning association for any rules regarding this subject. Most associations require that the bottle to be mounted within the confines of the safety roll cage with the safety pressure relief cap vented away from the driver's compartment.

**Figure 2 Nitrous Bottle Siphon Tube Orientation**

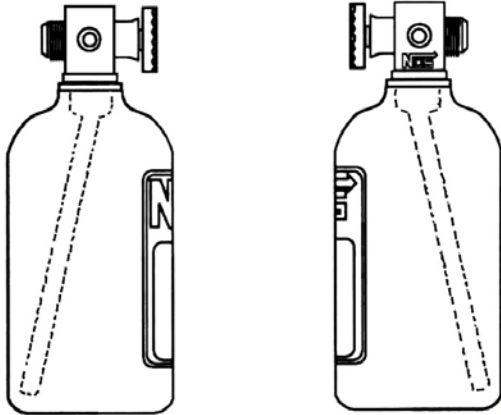

**Figure 3 Nitrous Bottle Mounting Orientations**

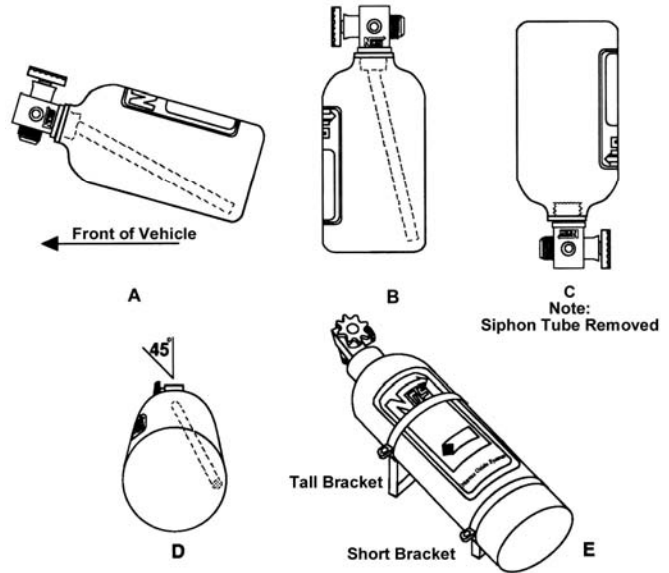

## 2.2 Bottle Orientation

Bottle placement is critical to the performance of your NOS nitrous system. It is important to understand how the bottle valve and siphon tube are assembled to properly orient the bottle in your vehicle and ensure that it picks up liquid nitrous while undergoing acceleration. All NOS nitrous bottles are assembled so that the bottom of the siphon tube is at the bottom of the bottle and opposite the bottle label (Figure 2).

Whenever the bottle is mounted in a lay-down position, the valve handle must be towards the front of the vehicle with the label facing up (Figure 3A).

If the bottle is mounted vertically, the valve handle and label must face toward the front of the vehicle (Figure 3B). This orientation will position the siphon tube at the back of the bottle where the liquid  $N_2O$  will be during acceleration.

**WARNING! DO NOT attempt to remove the siphon tube without completely emptying the bottle of all nitrous and pressure. Failure to completely empty the bottle will result in an explosive condition causing injury or death.**

A bottle mounted upside-down must have the siphon tube removed before use (Figure 3C). Non-siphon bottles can be specially ordered from NOS.

If the bottle must be mounted parallel to the axles of the vehicle (sideways), the valve handle and label must be angled at approximately  $45^\circ$  toward the front of the vehicle (Figure 3D). This orientation will position the siphon tube toward the rear of the bottle.

**NOTE:** When using a bottle with a siphon tube, the tall bracket should be at the valve end of the bottle and the short bracket at the bottom (Figure 3E).

The most efficient mounting is the lay-down position (Figure 3A) with the valve handle toward the front of the vehicle. This position allows the greatest amount of liquid to be used before the siphon tube begins to pick up gaseous nitrous oxide.

## 2.3 Bottle Installation

After you have determined the location and orientation of the nitrous bottle, use the following procedure to install the bottle:

**NOTE:** Numbers in parentheses ( ) refer to the parts list / assembly drawing number for the component. Figure 4 shows the installation assembly for the Factory Fuel Injection system.



Figure 4 Exploded View of Factory Fuel Injection System

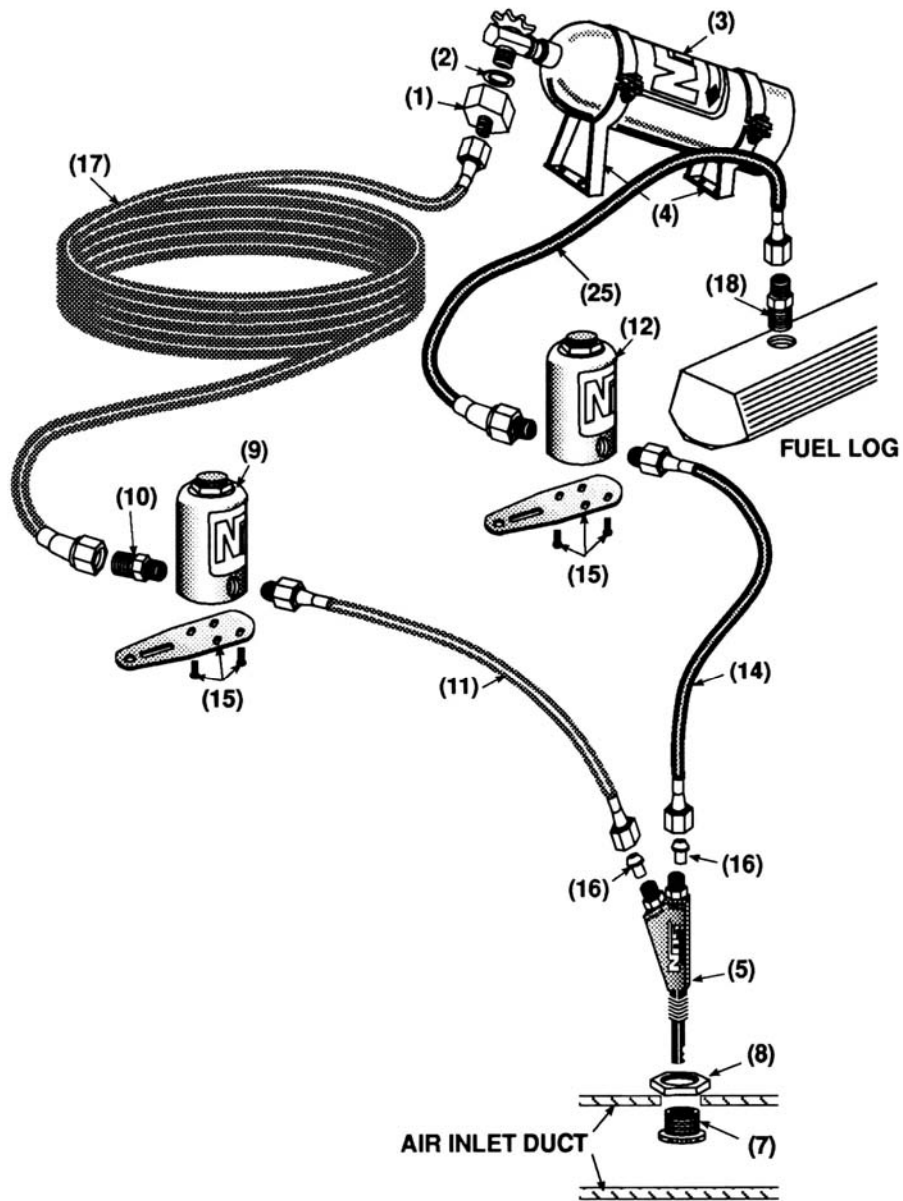

1. Install the bottle nut adapter (1) and washer (2) on the nitrous bottle (3). Tighten securely.
2. Loosely install the bottle mounting brackets (4) on the nitrous bottle, as shown in Figure 3E.
3. Locate the bottle/bracket assembly in the desired mounting location, ensuring that the location will provide easy access to the bottle valve, hose connection, and bracket clamp bolts to facilitate bottle changing.
4. Use the assembled bottle/bracket unit as a pattern to mark and drill four 5/16" holes in the mounting surface.
5. Mount the brackets securely to the surface (recommended minimum of 5/16" bolts or No. 12 sheet metal screws).
6. Secure the nitrous bottle in the mounting brackets and tighten the bracket clamps.

## 2.4 Fogger Nozzle Installation

**NOTE:** The recommended mounting location for the Fogger nozzle is in the air inlet duct, between the throttle body and the mass airflow sensor (in applications where a mass airflow sensor is used). If possible, install the nozzle between 6 and 12 inches as possible, as long as the nozzle discharge plume has a straight shot at the throttle body). See Figure 5. If you are attempting to install this kit on some other vehicle than it was designed for, call the NOS technical department to determine compatibility before continuing installation.

1. Select the desired mounting location for the Fogger nozzle (5). Make sure the nozzle and feed lines will not interfere with engine components or accessories.
2. Remove the air inlet duct.
3. A. **Metal Mounting Surface:** Drill a 1/4" hole perpendicular to the centerline of the inlet duct. Tap the hole using the 1/16" NPT tap (6). Tap depth should be deep enough, so that the discharge orifice of the nozzle is completely submerged into the duct, but not so deep that the Fogger nozzle bottoms out.

**NOTE:** All debris **must** be removed from the air inlet duct. Failure to do so can result in severe engine damage.

- B. **Rubber Mounting Surface:** Drill a 7/16" hole perpendicular to the inlet duct centerline through the inlet duct. Insert the Fogger nozzle adapter (7) into the 7/16" hole with the head inside the duct. Use Loctite or a similar compound on the Fogger nozzle adapter threads and securely tighten the Fogger nozzle adapter nut (8) to the Fogger nozzle adapter.

**NOTE:** Severe engine damage can occur if the spray nozzle adapter / nozzle assembly works loose from the air inlet duct. Ensure that the Fogger nozzle is **securely** tightened in the air duct.

4. Remove all debris from the air inlet duct.
5. Note the discharge side of the Fogger nozzle. Install the Fogger nozzle in the inlet duct with the discharge side pointed toward the engine.
6. Install the air inlet duct.

**Figure 5 Fogger Nozzle Installation Cut-Away**

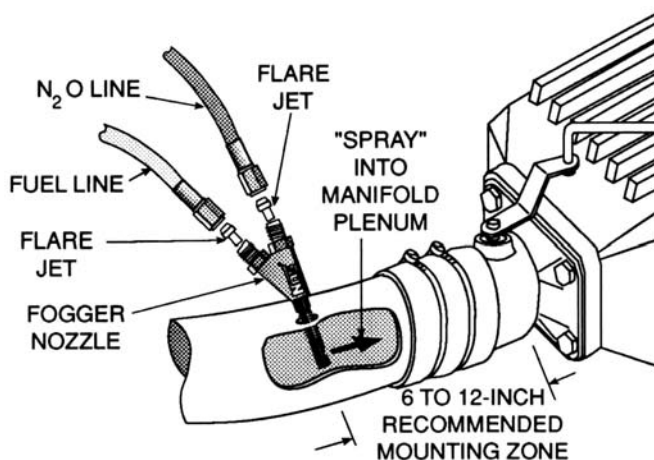

## 2.5 Solenoid Mounting

**CAUTION:** Do not overtighten the vise in the following procedure, or the solenoid will be damaged.

1. Clamp the nitrous solenoid (9) in a bench vise.
2. Thread the nitrous filter fitting (10) into the inlet port of the nitrous solenoid.
3. Thread the 1/8 NPT male end of the blue 2 ft. 3AN hose (11) into the outlet port of the nitrous solenoid. Remove from the vise.
4. Clamp the fuel solenoid (12) in a bench vise.
5. Thread 1/8 NPT male end of the red 4AN hose (25) into the inlet port of the fuel solenoid.
6. Thread the 1/8 NPT male end of the red 2 ft. 4AN hose (14) into the outlet port of the fuel solenoid. Remove from the vise.
7. Attach the nitrous solenoid to the solenoid mounting bracket.
8. Attach the fuel solenoid to the solenoid mounting bracket.

**NOTE:** Two solenoid brackets are included with this kit. You may mount both solenoids on one bracket, or mount them independently.

9. Select the mounting location for the solenoid assembly. Ensure that the assembly and lines do not interfere with engine accessories or body parts, and that hoses reach the Fogger nozzle inlet ports without being stretched or linked.
10. Securely mount the solenoid assembly.

## 2.6 Solenoid / Fogger Nozzle Hose Connection

1. Select the proper nitrous and fuel jets (16). Place the desired jets in the Fogger nozzle, making sure that the jets are inserted into the correct locations.

**NOTE:** If this system is being installed on a vehicle other than which it was originally intended for, please refer to Chapter 4, "Preparing for Operation", and Chapter 3, "Baseline Tuning Suggestions", for information on jet selection.

2. Connect and tighten the open end of the blue 2 ft. 3AN hose to the Fogger nozzle inlet port marked "nitrous". Hold the Fogger nozzle in position with a wrench to ensure the nozzle doesn't rotate out of position when the line is tightened.
3. Connect and tighten the open end of the red 2 ft. 3AN hose to the Fogger nozzle inlet port marked "fuel". Hold the Fogger nozzle in position with a wrench to ensure the nozzle doesn't rotate out of position when the line is tightened.

## 2.7 Nitrous Feed Line Mounting

**HINT:** Most late model vehicles have access plugs in the trunk floor, which are convenient for nitrous line routing. Following the fuel lines along the underbody, and entering the engine bay through the front fender well between the plastic inner fender panel and the body usually works well.

1. Determine the route for your nitrous feed line to follow. Ensure the path is clear of exhaust system, suspension, steering, wheels, electrical lines and components, and tires.
2. Feed the nitrous supply line (17) along the proposed route.
3. If it is necessary to support the nitrous supply line under the vehicle, use 1/2" Tinnerman clamps or nylon tie-wraps to support the line securely.
4. Attach the nitrous supply line to the nitrous bottle valve adapter (1).

**WARNING:** Nitrous oxide can cause death if inhaled. Severe frostbite can occur if allowed to contact the skin. Always point the nitrous line opening away from people when purging the line.

5. Purge the nitrous supply line.
  - A. Wrap the end of the nitrous line with a rag and hold securely.
  - B. Point the opening **away** from people.
  - C. Briefly open the bottle valve.
6. Attach the nitrous supply line to the filter installed in the nitrous solenoid inlet port.

## 2.8 Fuel Supply Connection

### 2.8.1 Fuel Supply Connection (Fuel Systems with Fuel Logs)

Supplemental fuel for the NOS nitrous oxide injection system is taken directly from the high-pressure log, which feeds the engine's fuel injectors. Figures 6 & 7 show the typical fuel log configurations. If you cannot locate the fuel log on your engine, consult a repair manual for your vehicle.

1. Identify the location of the fuel rail "test port" on the fuel log.
2. Remove the protective cap from the test port. Remove the Schrader valve from the test port using a tire valve core wrench.

**CAUTION:** When removing the Schrader valve from the fuel log test port, use caution. Fuel in the log is under high pressure. Never remove the Schrader valve when the engine is hot.

**NOTE 1:** If your vehicle's fuel log is not equipped with a test port, the fuel log will need to be removed and tapped for an "AN" fitting using steps 2A through 2F.

**NOTE 2:** Some vehicles equipped with a fuel log test port do not have threads on the test port compatible with the red 4AN supply line. If your vehicle is so equipped, you must either replace the test port fitting with the 4AN fitting, or install the brass 4AN fitting using steps 2A through 2F.

Figures 6 & 7 Typical Fuel Logs

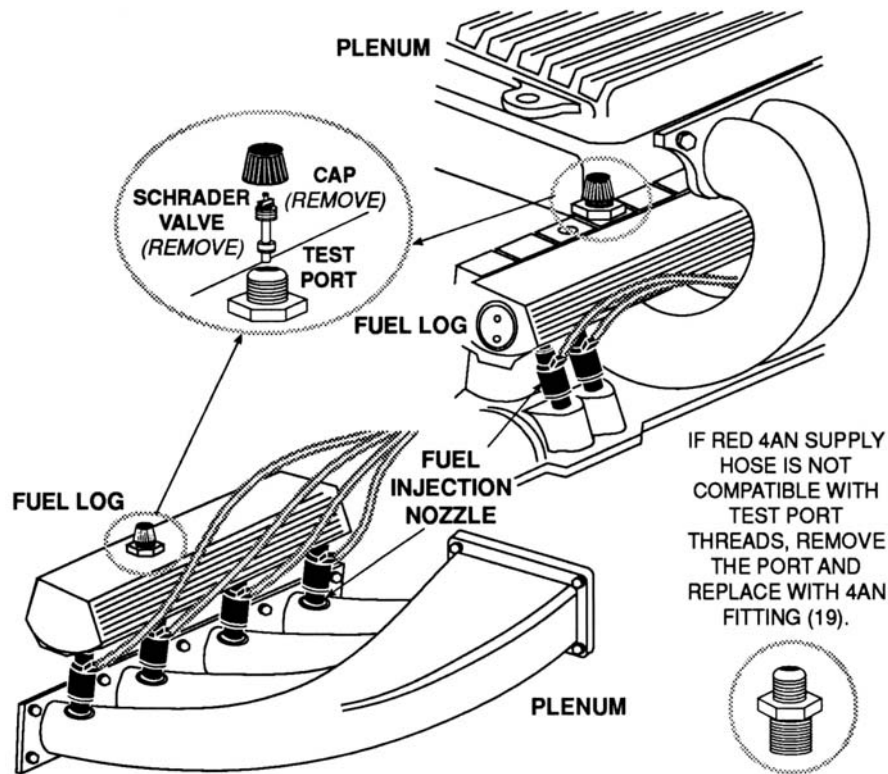

- A. Select a location on the fuel log for the brass 4AN fitting (18) to be located. Make sure that the fitting and line are clear of all engine components.
- B. Remove the fuel log from the engine. Drill a 1/4" hole in the fuel log, making sure that the hole is perpendicular to the mounting surface, and that the hole penetrates into the fuel log reservoir.
- C. Tap the 1/4" hole with the 1/16" NPT tap.

**CAUTION: All debris must be removed from the fuel log. Failure to do so will result in an engine failure.**

- D. Remove all debris from the fuel log.
- E. Install the brass fitting in the tapped hole.
- F. Install the fuel log on the engine.

3. Thread the remaining end of the 2 ft. red 4AN hose (23) to the test port / 4AN fitting.

### 2.8.2 Fuel Supply Connection (Fuel Systems without Fuel Logs)

Some engines utilize a fuel distribution system that has a central distribution block. This type system does not incorporate a fuel pressure "test port". Supplemental fuel for the NOS nitrous oxide injection kit must be acquired from the fuel injectors high pressure supply line.

1. Locate the central distribution block. It is easily identifiable by the fuel lines that run from the distribution block to each fuel injector. Connected to the central distribution block is the main fuel supply line. This line runs from the distribution block. Located between the fuel pump and the distribution block is the fuel filter. The desired location to "tap" into the fuel line is between the fuel filter and the distribution block.
2. Examine the outlet port of the fuel filter or the inlet to the central distribution block for a "banjo" bolt fitting. See Figure 12. Remove the fitting and examine the diameter of the shank of the fitting. To use this fitting for the supplemental fuel supply, the diameter must be sufficient for a 1/4" hole to be drilled through the centerline of the fitting. See Figure 13.
3. Drill a 1/4" hole through the centerline of the banjo fitting.
4. Tap the 1/4" hole with the 1/16" NPT tap.

**CAUTION: All debris MUST be removed from the inlet fitting. Failure to do so can result in severe engine damage.**

5. Thread the brass 1/16" NPT to 4AN fitting (19) into the tapped hole.

6. Install the modified banjo fitting into the fuel filter.
7. Thread the open end of the 2 ft. red 4AN hose (17) into the test port/4AN fitting.

**Figure 8 Fuel Filter/Banjo Fitting**

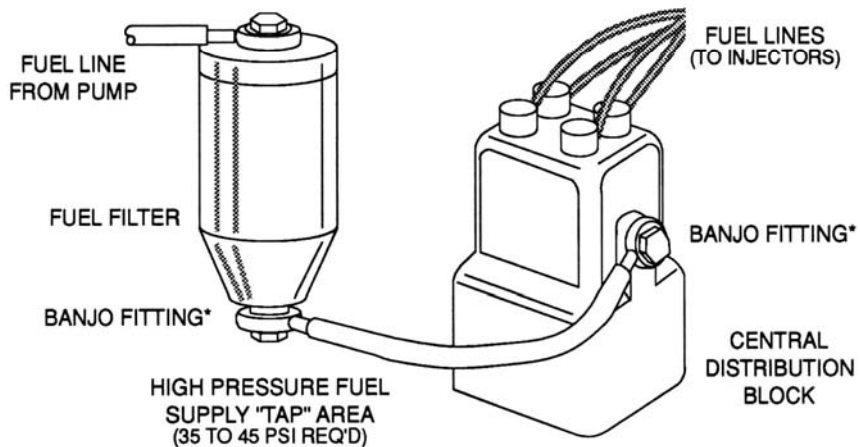

\* BANJO FITTING IN EITHER LOCATION MAY BE DRILLED AND TAPPED AS PER FIGURE 13

**Figure 9 Schematic of "Drilled Out" Banjo Fitting**



**Figure 10 Factory Fuel Injection System Wiring Schematic**

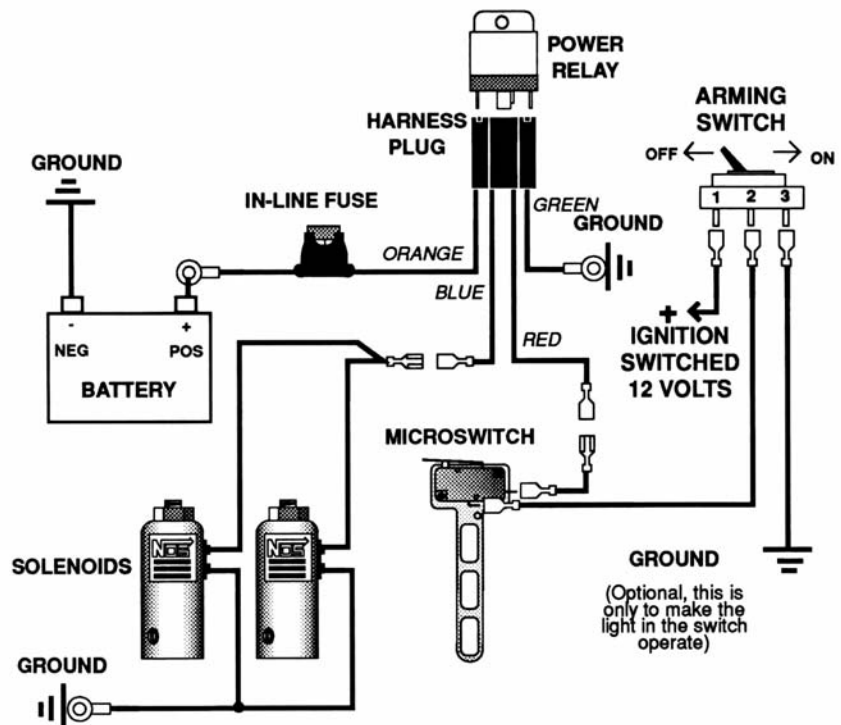

## 2.9 Electrical System Installation

Refer to Figure 10 and the procedures in this section for electrical system installation.

**WARNING! Death or injury may occur from working on a charged electrical system**

1. Disconnect the car battery at the ground cable (if not already done).

**WARNING! Binding or dragging of the throttle linkage will create a potentially dangerous stuck-throttle condition. Ensure that the microswitch does not interfere with normal throttle linkage operation.**

2. Install the throttle microswitch (19) as follows:

**HINT:** The microswitch may be mounted to the bracket in a variety of positions and on either side of the bracket. The bracket may be bent to suit the application.

- A. Mount the throttle microswitch on the throttle body so that the throttle linkage movement triggers the microswitch.
  - B. Adjust the microswitch to trigger at wide-open throttle by adjusting the microswitch's position to ensure the actuation arm of the microswitch "clicks" at the same point your throttle linkage reaches wide-open throttle against the throttle stop (Figure 11, Position A).
  - C. Ensure that the throttle and switch can reach the activation position, as shown in Figure 11, Position B, by using the accelerator pedal. Have an assistant slowly press the pedal to the floor while you listen for the "click" of the microswitch.
3. Install the NOS arming switch (20) in the vehicle interior, within easy reach of the driver.
  4. Install the wiring relay (21) and relay harness (22) in the engine compartment near the battery. The relay's orange wire should reach the battery (+) terminal.
  5. Connect the orange relay wire to the battery (+) terminal. Install a 15 AMP fuse into the fuse socket.
  6. Connect one wire from each solenoid together. Join the solenoid wires to the blue relay wire.
  7. Join the remaining solenoid wires together. Connect to a good chassis ground.

**Figure 11 Microswitch Mounting**

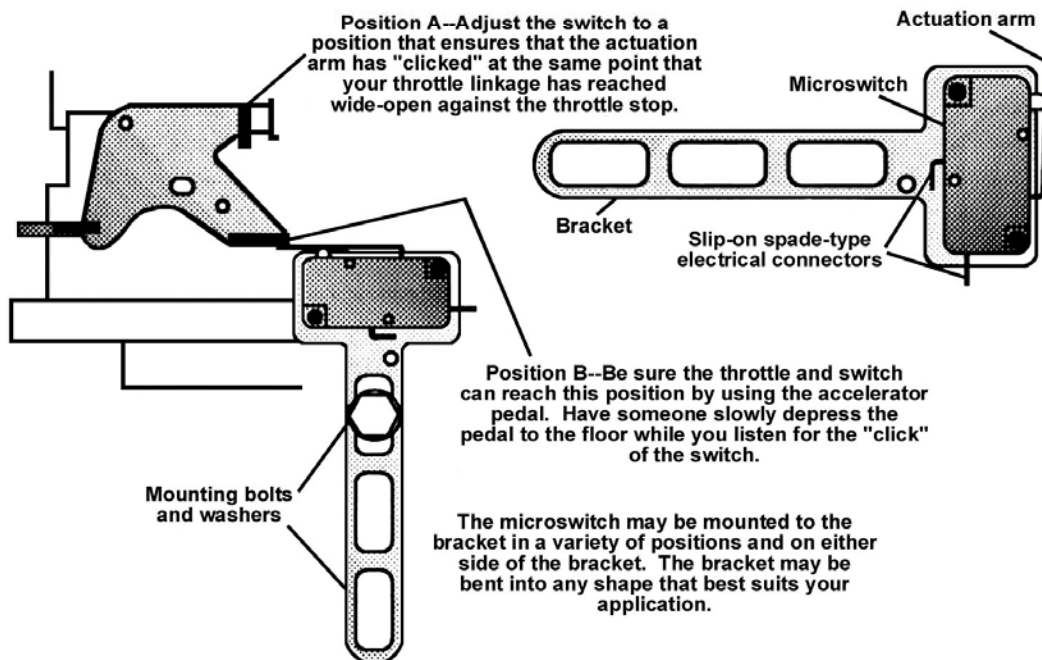

8. Connect the green relay wire to a good chassis ground.
9. Connect red relay wire to either terminal on the microswitch.
10. Connect the open terminal on the microswitch to the middle (#2) terminal on the arming switch.

11. Connect the #1 terminal on the arming switch to a switched 12 volt power source.
12. Connect the #3 terminal of the arming switch to a ground.
13. Reconnect the battery.
14. Turn the arming switch on.
15. Push the throttle wide open while the engine is off. Each solenoid should make a clicking noise if it is cycling correctly. If no noise is heard, check all the wiring connections and the wiring schematic in Figure 10.

## Chapter 3 Baseline Tuning Suggestions

**NOTE:** If you are adapting your kit to a vehicle other than that which the kit was originally designed for, you need to refer to Section 4.0, steps 2A through 2C before selecting a baseline tuning combination.

Your NOS System comes preset with nitrous and fuel jetting based upon engine displacement. The jetting combinations are conservative and are intended to work with stock ignition and +92 octane unleaded pump gasoline. Nitrous and fuel jetting combinations are derived based upon 900 psi (85° F) nitrous bottle pressure and fuel pressures as depicted in Table 3. Using the listed jetting and suggested fuel and nitrous pressure levels should yield safe and reliable power increase.

**Table 3 0-3.0L EFI System Jetting Map**

N <sub>2</sub> O Jet	Fuel Jet at PSI				
	20	30	40	50	60
34	20-22	18-21	17-19	17-18	16-17
37	22-23	20-22	19-21	18-20	17-18
39	32-34	26-29	23-25	21-23	19-21
43	36-38	29-31	25-27	22-24	20-22

Using these jetting combinations with lower bottle pressure and / or higher fuel pressure may produce an excessively rich condition. This can result in a loss of power, excessive exhaust smoke (black) or misfiring (backfiring through the exhaust).

If you experience any of these conditions, or you desire to maximize the power output from your system, you should refer to Chapter 5, "Advanced Tuning for Maximum Power".

**CAUTION: Use of excessive bottle pressure and/or inadequate fuel pressure can result in an excessively lean condition. In extreme cases, this will produce catastrophic engine failure.**

## Chapter 4 Preparing for Operation

**NOTE:** If you are adapting your kit to a vehicle other than that which the kit was originally designed for, you need to perform steps 2A through 2C before selecting a baseline tuning combination.

1. Turn on the ignition switch (vehicles with electric fuel pumps) or start the engine (vehicles with mechanical fuel pumps). Check for fuel leaks. Shut the vehicle off.
2.
  - A. Connect a fuel pressure gauge to the fuel pressure test port or, the 4AN fitting that you installed in the fuel rail / banjo fitting in Section 2.8.
  - B. Turn on the ignition switch (vehicles with electric fuel pumps) or start the engine (vehicles with mechanical fuel pumps). Check for fuel leaks. Record the fuel pressure. Shut the vehicle off.
  - C. Examine the jetting chart in Table 3. Locate the nitrous jet you are intending to use in column #1. Go across the top row to the fuel pressure your vehicle operates at. Find the box that corresponds to your fuel pressure and nitrous jet. If the recommended fuel jet was not included in your kit, phone the NOS technical department for assistance.
3. Install the correct fuel jet in the Fogger nozzle.
4. Turn the arming switch on. Set the engine speed at 2000 RPM. Briefly activate the microswitch. Engine speed should decrease, if the fuel delivery system is performing properly. If not, refer to Appendix A, Troubleshooting Guide.

**NOTE:** If your kit is installed on a vehicle other than that which it was intended for, care must be taken to ensure that the fuel delivery system of your vehicle is adequate. Before opening the nitrous bottle valve, repeat step 2B with the vehicle under wide-open throttle acceleration. Fuel pressure should not deviate more than 4-5 psi when the fuel side of the nitrous system is activated. If the fuel pressure drop is greater than this, a supplemental fuel pump will be required. Contact the NOS technical department for recommendations.

5. Open the nitrous bottle valve.
6. Inspect the nitrous lines and fittings for leaks.
7. ENJOY!

## Chapter 5 Advanced Tuning for Maximum Power

After performing the Baseline Tuning Suggestion—Chapter 3, if you desire to maximize the performance of your system, perform the following:

**NOTE:** Always perform the nitrous/fuel ratio modifications listed in Section 5.1 before attempting to optimize the ignition timing (Section 5.2). Improper nitrous/fuel ratio combinations can mislead you when attempting to optimize the ignition timing.

### 5.1 Determining Optimum Nitrous/Fuel Jetting

The factory calibrated nitrous / fuel ratio included to provide you with a safe starting point. It is intended to be used with 900 psi nitrous bottle pressure and fuel pressures as stated in Table 3. In some instances, slight changes in fuel pressure may produce performance gains.

1. Stabilize the nitrous bottle pressure at 900 psi.
2. Perform a dynamometer pull or a full throttle pass down the racetrack. Note the power reading or vehicle mph (not e.t.). Examine spark plugs for the indication of lean or rich nitrous/fuel conditions (refer to Figure 12 for tips on reading the spark plugs).
  - 2A. If spark plugs appear to be excessively rich, decrease the fuel jet size 2 steps (ex. 38 to 36, 32 to 30, etc;).
  - 2B. If spark plugs appear to be excessively lean, increase the fuel jet size 2 steps.
  - 2C. If spark plugs have a “like new” appearance on the porcelain and electrode, do not make a fuel jetting change.
3. Repeat steps 1 and 2 until the desired mixture is obtained.

**Figure 12 Spark Plug Condition**

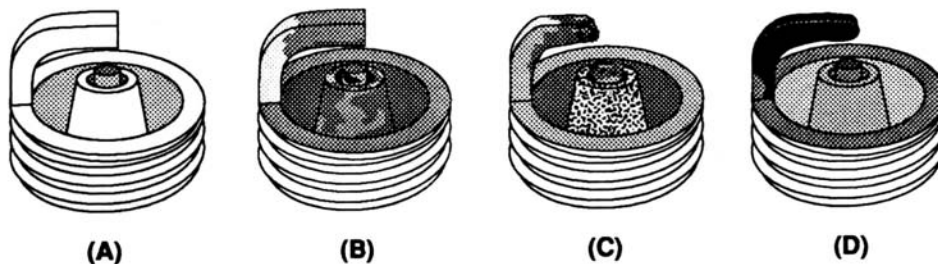

#### How to Read Spark Plugs from a Nitrous Oxide Injected Engine

##### A. Correct Timing, Mixture, and Spark Plug Heat Range

Ground strap retains a “like new” appearance. Edges are crisp, with no signs of discoloration. Porcelain retains clear white appearance with no “peppering” or spotting.

##### B. Excessively Rich Mixture

Porcelain may be fuel stained, appearing brown or black. In extreme cases, ground strap, electrode, and porcelain may be damp with gasoline, or smell of fuel.

##### C. Detonation

Edges of the ground strap may become rounded. Porcelain has the appearance of being sprinkled with pepper, or may have aluminum speckles. During heavy detonation, the ground strap tip may burn off. This phenomena can result from excessive ignition timing, too high a heat range spark plug, or inadequate fuel octane.

##### D. Excessively Lean Mixture

Edges of the ground strap may become rounded. Under moderate overheating, the tip of the ground strap can discolor, usually turning purple, or the entire ground strap can become discolored.



## 5.2 Determining Optimum Ignition Timing

**IMPORTANT!** Ignition timing should be retarded approximately 2 degrees per 50 HP increase due to nitrous oxide injection. Start with the engine's best total timing and reduce from there. Use the initial settings, which are 2-3 degrees more retarded than you expect to be optimum.

**Example:**

Total Ignition Timing with Nitrous-----	38°
100 HP Increase from Nitrous-----2°/50HP-----	4° Retard
Initial Safety Margin-----	<u>2° Retard</u>
Initial Timing with Nitrous-----	32°

The following scheme for determining ignition timing should allow you to determine the optimum setting for your vehicle, without incurring engine damage during the tuning phase.

1. Estimate the reduced ignition timing that you think will produce the best power, based upon the 2-degree retard per 50 horsepower increase rule.
2. Set the ignition timing 2 to 3 degrees retarded from your best power estimate setting.
3. Stabilize the nitrous bottle pressure at 900 psi.
4. Perform a dynamometer pull or a full throttle pass down the racetrack. Note the power reading or vehicle mph.
5. Increase the ignition timing 2 degrees.
6. Perform a dynamometer pull or a full throttle pass down the racetrack. Note the power reading or vehicle mph. Examine the spark plugs for signs of detonation (refer to Figure 12 for tips on reading spark plugs).
  - 6A. If power increase or vehicle mph increase **and** spark plugs show no sign of overheating or detonation, increase the ignition timing 2 degrees.
  - 6B. If power increase or vehicle mph increase **and** spark plugs begin to show slight signs of detonation—STOP. Do not advance the timing further. You may choose to reduce the timing 2 degrees at this point for an extra margin of safety.
  - 6C. If power decreases or vehicle mph decreases, reduce the ignition timing 2 degrees.
7. Repeat step 6 until optimum ignition timing is obtained.

## Chapter 6 Routine Maintenance

### 6.1 Nitrous Solenoid Filter

When nitrous bottles are refilled they can become contaminated with debris, if the refiller does not have an adequate filter in his transfer pump mechanism. Contaminants in the bottle will eventually become lodged in the nitrous solenoid filter fitting.

You should periodically (after every 20-30 pounds of nitrous usage) examine the mesh in the nitrous filter for debris.

To clean the filter, follow the following steps:

1. Close the valve on the nitrous bottle.
2. Empty the main nitrous feed line.
3. Disconnect the main nitrous feed line from the nitrous solenoid.
4. Remove the nitrous filter fitting from the nitrous solenoid.
5. Remove **all** Teflon paste debris from the solenoid inlet port threads and from the nitrous solenoid filter pipe threads.
6. Examine the mesh in the nitrous filter fitting for contaminants. Blow out debris with compressed air, if necessary.
7. Apply fresh Teflon paste to the nitrous filter pipe threads. Reinstall the filter in the nitrous solenoid.
8. Reconnect the main nitrous supply line to the nitrous solenoid.

## 6.2 Nitrous Solenoid Plunger

### 6.2.1 General Information

The seals used in NOS nitrous solenoid plungers are constructed from materials, which are designed to be used with nitrous oxide. When kept free from fuel contaminants or from overpressurization, they should provide trouble free performance.

You should periodically (after every 20-30 pounds of nitrous usage) examine the seal in the nitrous solenoid plunger.

The seals used in NOS nitrous solenoid plungers are designed to work at pressures up to 1100 psi. Exposing the plunger to excessive pressure (whether the vehicle is sitting or in-use) can result in the seal in the plunger swelling or in extreme cases disintegrating.

**NOTE:** The seals are designed so that if they fail due to overpressurization, they will not leak, the valve will just fail to flow nitrous oxide.

Swelling of the nitrous solenoid plunger seal will reduce nitrous flow (causing an excessively rich nitrous/fuel condition and a loss of power).

### 6.2.2 Nitrous Solenoid Plunger Disassembly and Inspection

1. Close the valve on the nitrous bottle.
2. Empty the main nitrous supply line.
3. Remove the retaining nut from the nitrous solenoid.
4. Remove the coil and housing from the nitrous solenoid base.
5. Unscrew the stem from the nitrous solenoid base. Do this by double nutting the stem, or by using a solenoid stem removal tool (NOS P/N 16665-SNOS). **Do not use pliers on the solenoid stem. Damage to the stem will result.**
6. Remove the stem, spring, and plunger from the solenoid base.
7. Examine the plunger seal for swelling. The seal surface should be flat, except for a small circular indentation in the center of the seal;

A fuel-contaminated seal will protrude from the plunger and be dome-shaped. A fuel-contaminated seal may return to its original shape if left out in the fresh air for several days. It may then be returned to service.

A seal, which has been overpressurized, may be dome-shaped, or the sealing surface may be flat with the seal protruding out of the plunger. A dome-shaped seal may return to its original shape if left out in the fresh air for several days. It may then be returned to service. A seal, which is flat, but protrudes from the plunger body has probably failed internally and should be replaced.

Figure 13 Exploded View of a Typical Solenoid

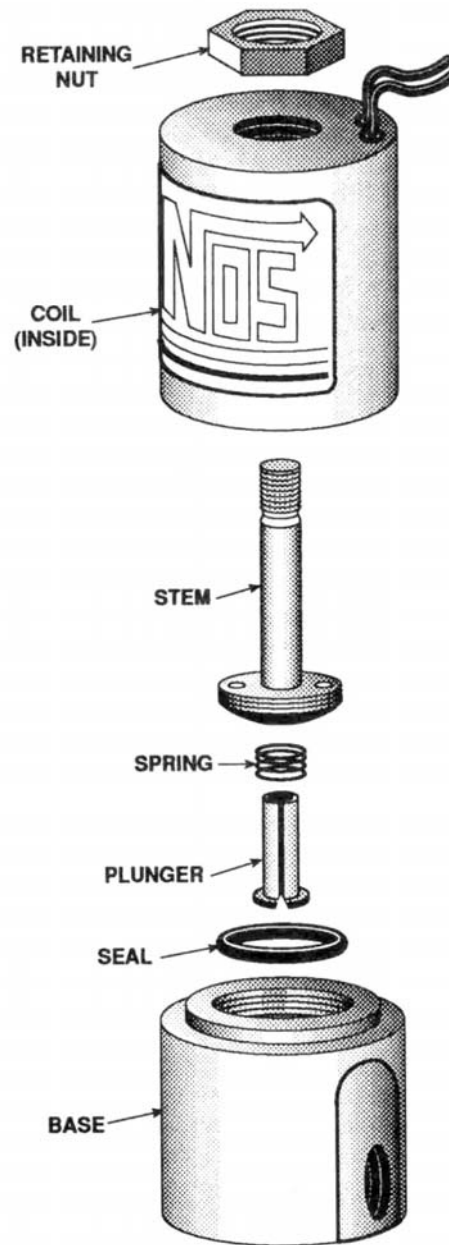

## Appendix A Troubleshooting Guide

The troubleshooting chart on the following pages should help determine and rectify most problems with your installed NOS system. If you still need assistance determining or fixing problems, call the NOS Technical Support at 1-866-GOHOLLEY.

PROBLEM	POSSIBLE CAUSES	DIAGNOSTIC PROCEDURE	CORRECTIVE ACTION
No change in engine speed when the fuel solenoid is activated (Preparing for Operation—Chapter 4).	System wired incorrectly.	Compare wiring to schematic in Fig. 10.	Wire per instructions.
	Restricted fuel line.	Inspect fuel line for restrictions (crimped or plugged).	Remove restrictions.
	Malfunctioning fuel solenoid.	Turn arming switch ON. Cycle the microswitch. Solenoid should make “clicking” noise.	Repair/replace solenoid.
Change in engine speed when nitrous bottle valve is opened (Preparing for Operation—Chapter 4).	Malfunctioning nitrous solenoid.	Remove and inspect solenoid.	Repair/replace solenoid.
Engine runs rich when system is activated.	Bottle valve not fully opened.	Check bottle valve.	Open valve fully.
	Bottle mounted improperly.	Check bottle orientation.	Mount bottle properly.
	Plugged nitrous filter.	Inspect filter.	Clean/replace filter.
	Low bottle pressure.	Check bottle temperature.	Set bottle temperature to 75° to 85°F.
	Inadequate nitrous supply.	Weigh bottle.	Fill bottle. 1-800-99-REFILL
	Mismatched N <sub>2</sub> O/fuel jetting.	Compare jetting to recommended values.	Install correct jets.
	Excessive fuel pressure.	Install fuel pressure gauge, such as NOS P/N 15906NOS, in the fuel line. Measure the pressure during acceleration with the system activated.	Regulate pressure down, or install smaller fuel jetting.
	Loose nitrous solenoid wiring.	Inspect the solenoid wiring.	Repair wiring.
	Malfunctioning nitrous solenoid.	<b>WARNING:</b> <i>Solenoid discharges nitrous at a high rate. Don't inhale nitrous; death may occur. Skin contact may cause frostbite.</i> Close bottle valve. Disconnect the nitrous solenoid outlet port. Disconnect the solenoid (+) lead. Open the nitrous bottle valve. Connect the +12V to the solenoid. Solenoid should discharge N <sub>2</sub> O at a high rate.	Rebuild solenoid.
No change in performance when system is activated.	System wired incorrectly.	Compare nitrous wiring to schematic (Fig. 10).	Wire system per instructions.
	Loose ground wire(s).	Connect 12V test light to battery (+) terminal. Check for continuity at grounds noted in Fig. 10.	Tighten/repair loose grounds.
	Malfunctioning arming switch.	Turn arming switch on. Connect 12V test light to battery (-) terminal. Check for power at pole #2.	Replace pushbutton
	No power to arming switch.	Connect 12V test light to battery (-) terminal. Check for power at pole #1 on arming switch.	Repair wiring.
	Malfunctioning throttle microswitch.	Temporarily disconnect power relay red wire from microswitch. Connect 12V test light to battery (-) terminal. Manually set microswitch ON. Check for continuity at microswitch positive terminal (Fig. 10).	Replace throttle microswitch.
	Overly rich fuel condition.	Check for black smoke or backfiring through exhaust with system activated.	Install smaller fuel jet or decrease fuel pressure.
Engine detonates mildly when system is activated.	Excessive ignition timing.	Check ignition timing.	Reduce timing in 2° increments.
	Inadequate octane fuel.		Use higher octane fuel.
	Spark plug heat range too high.		Reduce spark plug heat range (maximum 2 steps).
	Too much nitrous flow.		Reduce nitrous jetting.

Engine detonates heavily when system is activated.	Inadequate fuel delivery due to: Plugged fuel filter.	Inspect fuel filter.	Clean or replace filter.
	Crimped fuel line.	Inspect fuel line.	Replace crimped line.
	Weak fuel pump.	Install fuel pressure gauge, such as P/N 15906NOS, in the fuel line. Run engine under load at wide-open throttle, with system activated. Fuel pressure should be within 5 PSI of fuel pressure at idle.	Repair/replace fuel pump.
High-rpm misfire when system is activated.	Excessive spark plug gap.	Inspect spark plugs.	Set spark plug gap at 0.030" to 0.035".
	Weak ignition/ignition component failure.	Inspect components (plug wires, distributor cap, etc.)	Replace worn components.
Surges under acceleration when system is activated.	Inadequate supply of nitrous.	Check bottle weight.	Replace with full bottle.
	Bottle mounted incorrectly.	Compare bottle position and orientation to instructions (Figures 2 & 3).	Mount or orient bottle correctly.

## Nitrous Oxide Accessories

NOS systems are calibrated for optimum performance with a bottle pressure of 900-950 psi. The pressure will change with temperature. Heater kits are thermostatically controlled to keep the bottle near 85° F to provide correct pressure. **Bottle Heater (P/N 14164NOS)** is available for 10 & 15 lb. bottles.

Insulating the bottle helps maintain pressure by keeping heat in the bottle when it's cold, or heat out when it's hot outside. The blankets are made of a rugged, easily cleaned Nylon outer shell with insulation. It's also an excellent "dress up" accessory and perfect for "covering" battle-scarred bottles. **Bottle Blanket (P/N 14165NOS)** is a 7" diameter blanket for the 10 lb. bottle.

**10-20 lb. Bottle Heater P/N 14164NOS**



**10 lb. Bottle Blanket P/N 14165NOS**



**Throttle/RPM-Activated Switch P/N 15879NOS**



**Remote Bottle Valve P/N 16058NOS**



The **Throttle/RPM-Activated Switch (P/N 15879NOS)** allows hands-free nitrous operation and prevents nitrous from being injected at speeds above or below operator-set levels. It greatly reduces the chance of accidental engine damage. The ON/OFF levels adjust from 2000 to 9000 RPM. **NOTE:** P/N 15879NOS is not designed to work on vehicles with distributorless ignition systems. Call NOS Technical Support for the right RPM-Activated switch for your particular vehicle.

The **Remote Bottle Valve (P/N 16058NOS)** is the perfect convenience accessory—it electronically turns the nitrous bottle on and off with the flick of a switch—no more trips to the trunk. It is also great as a safety shut-off valve. It operates on 12V DC. The complete kit includes hardware and installation instructions.

## NOS Technical Support

**Toll-Free Phone: 1-866-GOHOLLEY**

**Phone: 1-270-781-9741**

**Fax: 1-270-781-9772**

**For online help, please refer to the Tech Service section of our website: [www.holley.com](http://www.holley.com)**

**A5059-1-SNOS**

**Date: 6-4-03**