



**BATTERY CHARGER
OWNER'S MANUAL**

**POWER CHARGER Part # 74016
12-16 volt Amp**

----CAUTION----

**READ THIS MANUAL CAREFULLY FOR
RULES OF SAFE OPERATION AND
PROPER USE OF THIS CHARGER**

*****SAVE THESE INSTRUCTIONS*****

STANDARD FEATURES

- ◆ BATTERY TYPE SWITCH (BTS)
- ◆ HIGH ENERGY RETURN, FAST CHARGING
- ◆ CONSTANT CURRENT FIRST STAGE
- ◆ DUAL VOLTAGE LIMIT (CYCLIC/ STANDBY)
- ◆ AUTOMATIC SAFTEY OVERRIDE TIMER
- ◆ START DELAY ON BATTERY CONNECT
- ◆ SHORT AND REV. CONNECTOR SHUTDOWN
- ◆ RUGGED SCR PHASE CONTROL
- ◆ MAINS ZERO-CROSSING BATTERY SENSING

***For Technical Assistance, Call Moroso's Tech Line at
(203) 458-0542, 8:30am – 5:00pm Eastern Time***

*MOROSO PERFORMANCE PRODUCTS, INC
80 CARTER DR · GUILFORD, CT 06437
Phone: (203) 453-6571 · Fax: (203) 453-6906*

Rev.A
021705

Visit Us At www.moroso.com

74016INST

**POWER CHARGER
12 & 16 VOLT
SPECIFICATIONS**

POWER CHARGER

MODEL RT 1216/30A

INPUT: 117 Volts AC 60Hz, 720 VA 7amps

OUTPUT: 12 or 16 Volts DC, 30 Amps

Full Wave Phase Controlled Rectification

CONTROL:

Voltage limit:

Normal Mode 2.42 V/Cell

Gel-Cell Mode 2.33 V/Cell

Liquid Electrolyte Mode 2.62 V/Cell

Current limited to AMP rating MEAN DC.

Automatic timer starts when first stage voltage limit reached.

Proportional CV stage timer - t/2+1 hour.

Constant voltage 2.3 V/Cell after timeout, with

Temperature Compensation.

PROTECTION:

Electronic reverse polarity. Short circuit shutdown and current limit.

Manual Reset Circuit Breaker

BATTERY TYPE & RATING

This charger is for use with Lead Acid Batteries of Minimum capacity 50 AT, Gel Cell, Absorbed Electrolyte or Liquid Electrolyte types by using the BTS (Battery Type Switch) (See Page 11 BTS)

DIMENSIONS: (Inches) (Wall & Table Mounting)

12.0 "WIDE, 70 FRONT TO BACK, 7.0" HIGH



IMPORTANT SAFETY INSTRUCTIONS
--

1. **SAVE THESE INSTRUCTIONS**-- This manual contains important safety and operating instructions.
2. Before using this battery charger, read all instructions and cautionary markings on (1) the battery charger, (2) the battery, (3) product using the battery.
3. **CAUTION**--To reduce risk of injury, charge only lead acid, maintenance free or flooded lead acid type rechargeable batteries. Other types of batteries may burst causing personal injury and damage.
4. Do not expose charger to rain or snow.
5. Use of an attachment not recommended or sold by the battery charger manufacturer may result in a risk of fire, electric shock or injury to person.
6. To reduce risk of damage to electric plug and cord, pull by plug rather than cord when disconnecting charger.
7. Make sure cord is located so that it will not be stepped on, tripped over or otherwise subjected to damage or stress.
8. An extension cord should not be used unless absolutely necessary. Use of improper extension cord could result in risk of fire and electrical shock. If an extension cord must be used, make sure:
 - a. That pins on plug of the extension cord are the same number, size and shape as those of the plug on the charger.
 - b. That the extension cord is properly wired and in good electrical condition.
 - c. That the wire size is large enough for the A/C ampere rating of the charger as specified in the table below:

LENGTH OF CORD (FEET)	25	50	100	100
AWG WIRE SIZE	18	18	16	14
9. Do not operate charger with damaged cord or plug.

REPLACE THEM IMMEDIATELY.

10. Do not operate charger if it has received a sharp blow, been dropped or otherwise damaged in any way; return it to a qualified service source.
11. Do not disassemble charger; Take it to a qualified service source when repair or service is required. Incorrect reassembly may result in a risk of electrical shock or fire.
12. To reduce risk of electrical shock, unplug charger from outlet before attempting any maintenance or cleaning.

WARNING RISK OF EXPLOSIVE GASES
--

1. WORKING IN VICINITY OF A LEAD-ACID BATTERY IS DANGEROUS. BATTERIES GENERATE EXPLOSIVE GASES DURING NORMAL BATTERY OPERATION. FOR THIS REASON, IT IS OF THE UTMOST IMPORTANCE THAT EACH TIME BEFORE USING YOUR CHARGER, YOU READ THIS MANUAL AND FOLLOW THE INSTRUCTIONS EXACTLY.
2. To reduce risk of battery explosion, follow these directions and those published by the battery manufacturer and the manuf. of any equipment you intend to use in vicinity of the battery. Review cautionary marking on these products and on engine.

PERSONAL PRECAUTIONS

1. Someone should be within range of your voice or close enough to come to your aid when you work near a lead-acid battery.
2. Have plenty of fresh water and soap nearby in case battery acid contacts skin, clothing or eyes.
3. Wear complete eye protection and clothing protection. Avoid touching eyes while working near battery.
4. If battery acid contacts skin or clothing, wash immediately with soap and water. If acid enters eyes, immediately flood eyes with running cold water for at least 10 minutes and get medical attention immediately.
5. NEVER smoke or allow a spark or flame in the vicinity of battery or engine.

6. Be extra cautious to reduce risk of dropping a metal tool onto battery. It might spark or short circuit battery or other electrical part that may cause explosion.
7. Remove personal metal items such as rings, bracelets, necklaces, and watches when working with a lead acid battery. A lead acid battery can produce a short circuit current high enough to weld a ring or the like to metal, causing a severe burn.
8. Use charger for charging a LEAD-ACID BATTERY ONLY. Do not use battery charger for charging dry-cell batteries that are commonly used with home appliances. These batteries may burst and cause injury to persons and damage to property.
9. NEVER charge a frozen battery.

PREPARING TO CHARGE

1. If necessary to remove battery from vehicle to charge, always remove grounded terminal from battery first. Make sure all accessories in vehicle are off so as not to cause an arc.
2. Be sure area around battery is well ventilated while battery is being charged. Gas can be forcefully blown away by using a piece of cardboard or other nonmetallic material as a fan.
3. Clean all battery terminals. Be careful to keep corrosion from coming in contact with eyes.
4. Add distilled water in each cell until battery acid reaches level specified by battery manufacturer. This helps purge excessive gas from cells. Do not overfill. For a battery without cell caps, carefully follow manufacturer's recharging instructions.
5. Study all battery manufacturer's specific precautions such as removing or not removing cell caps while charging and recommended rates of charge.
6. Determine voltage of battery by referring to car or equipment owner's manual and make sure it matches output rating of battery charger.

VOLTAGE SELECTOR SWITCH

WARNING The front panel switch has two settings, marked 12V and 16V, with OFF in the center.

The switch must be set to 12 Volts when charging 12 Volt (SIX CELL) batteries.

The switch must be set to 16 Volts ONLY when charging 16 Volt (EIGHT CELL) batteries.

Sixteen Volt (Eight Cell) batteries are special high performance batteries used in racing applications only, which need a higher voltage recharge. They are identified as 16 Volts on the battery label, and have eight cell caps on top of the battery.

Setting the charger to 16 Volts, when connected to the "12-Volt Post" on a three terminal 16 Volt battery, will apply excessive voltage to the battery cells and to the vehicle electrical system, and may result in emission of explosive gasses, overheating and damage to the vehicle electrical system. Damage caused by incorrect setting of the Voltage is not covered under the warranty, so check which type of battery is connected before using the charger. If in any doubt, use only the 12 Volt setting.

CHARGER LOCATION

1. Locate charger as far away from battery as charging cables will permit.
2. Never place charger above battery being charged; gasses from battery will corrode and damage charger.
3. Never allow battery acid to drip on charger when reading specific gravity or filling battery.
4. Do not operate charger in a closed-in area or restrict ventilation in any way.
5. Do not set a battery on top of charger.

DC CONNECTION PRECAUTIONS

1. Connect and disconnect DC output only after removing AC cord from electric outlet. Never allow clips to touch each other.
2. Attach clips to battery posts and twist or rock back and forth several times to make a good connection. This tends to keep clips from slipping off terminals and helps to reduce risk of sparking.

FOLLOW THESE STEPS WHEN BATTERY IS INSTALLED IN VEHICLE. A SPARK NEAR A BATTERY MAY CAUSE BATTERY EXPLOSION.

TO REDUCE RISKS;

1. Carefully position AC and DC cords to reduce risk of damage by hood, door or moving engine parts.
2. Stay clear of fan blades, belts, pulleys and other parts that can cause injury to persons.
3. Check polarity of battery posts. POSITIVE (POS. P. +), battery posts usually have a larger diameter than the NEGATIVE (NEG. -.) posts.
4. Determine which post of battery is grounded (connected) to the chassis.
5. For negative-grounded vehicle, connect POSITIVE (RED) clip from battery charger to POSITIVE (POS, P,+) UNGROUNDED POST OF THE BATTERY. Connect NEGATIVE (BLACK) clip to vehicle chassis or engine block away from battery. DO NOT CONNECT CLIPS TO CARBURETOR, FUEL LINES, OR SHEET METAL BODY PARTS. Connect to a heavy gauge metal part of the frame or engine block.
6. For positive-grounded vehicle, connect NEGATIVE (BLACK) clip from battery charger to the NEGATIVE (NEG, N, -) UNGROUNDED POST OF THE BATTERY. Connect POSITIVE (RED) clip to the vehicle chassis or engine block away from battery.

DO NOT CONNECT CLIP TO CARBURETOR, FUEL LINES OR SHEET METAL BODY PARTS.

7. When disconnecting charger, turn switches to off, disconnect AC cord, remove clip from vehicle chassis and then remove clip from battery terminal.

FOLLOW THESE STEPS WHEN BATTERY IS OUTSIDE VEHICLE. A SPARK NEAR THE BATTERY MAY CAUSE BATTERY EXPLOSION.

TO REDUCE RISK

1. Check polarity of battery posts. POSITIVE (POS, P, +) battery post usually has a larger diameter than the NEGATIVE (NEG, N, -) post.
2. Attach at least a 24-inch long, 6 gauge (AWG) insulated battery cable to the NEGATIVE (NEG, N, -) battery post.
3. Connect POSITIVE (RED) charger clip to POSITIVE (POS, P, +) of the battery.
4. Position yourself and free end of cable as far away from battery as possible, then connect NEGATIVE (BLACK) charger clip to free end of cable.
5. Do not face battery when making final connection.
6. When disconnecting charger, always do so in reverse sequence while as far away from battery as practical.

GROUNDING AND AC POWER CORD CONNECTING INSTRUCTIONS

Charger should be grounded to reduce risk of electrical shock. Charger is equipped with an electrical cord having an equipment grounding conductor and a grounding pin. This plug must be plugged into an outlet that is properly installed and grounded in accordance with all local codes and ordinances.

DANGER-- Never alter AC cord or plug provided. If it will not fit outlet, have proper outlet installed by a qualified electrician. Improper connection can result in a risk of an electrical shock.

This battery charger is for use on a nominal 117 volt AC circuit and has a grounded plug that looks like the plug illustrated in sketch (A). A temporary adapter, which looks like the adapter illustrated in sketches (B) & (C) may be used to connect this plug to a two-pole receptacle as shown in sketch (B) if a properly grounded outlet is not available. The temporary adapter should be used only until a properly grounded outlet can be installed by a qualified electrician.

* Optional Voltages are available.

NOTE: USE OF AN ADAPTER IS NOT ALLOWED IN CANADA. If a grounding type receptacle is not available. DO NOT use this appliance in CANADA until the proper outlet is installed by a qualified electrician.

DANGER-- Before using an adapter as illustrated, be certain that the center screw of the outlet plate is grounded. The green colored rigid ear or lug extending from the adapter must be connected to a properly grounded outlet. Make certain it is grounded.

If necessary, replace original outlet cover plate screw with a longer screw that will secure adapter ear or lug to outlet cover plate and make ground connection to grounded outlet.

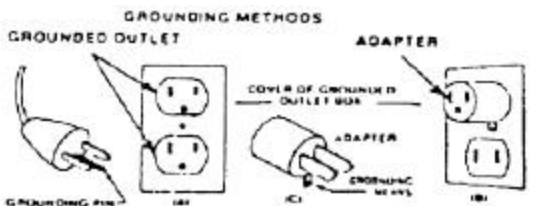

POWER CHARGER OPERATING INSTRUCTIONS

This charger is suitable for use with all types of lead acid batteries, including the new types of maintenance free and gelled electrolyte batteries.

1. Disconnect vehicle battery cables.
2. Connect charger to battery. Ensure correct polarity. - BLACK lead to negative (-) terminal and RED lead to POSITIVE (+) terminal.

NOTE: THIS CHARGER IS PROTECTED AGAINST REVERSE CONNECTION. CHARGING WILL NOT COMMENCE IF BATTERY IS INCORRECTLY CONNECTED.

3. Connect the charger to AC power supply.

The following LED sequence details the operation of the charger equipped with the Hibernator Chip:

CHARGE! HIBERNATE (Red LED Indicator)

ON CONSTANT= CHARGING (Battery and AC Connected,
First stage charging in progress)

ON FLASHING = HIBERNATE (Battery and AC Connected,
charger is in auto-shutoff mode)

80% POWER ON (YELLOW LED Indicator)

ON CONSTANT = 80% CHARGED (Battery is charging and
has reached the second stage Constant Voltage)

ON FLASHING = POWER ON (AC Supply is connected,
charger is on, but battery is not connected)

READY! TIMEOUT (GREEN LED Indicator)

ON CONSTANT = Battery ready, charge cycle completed

ON FLASHING = Timeout error, battery or charger may be
defective or other fault.

NOTE: - Power On self test indication.

When the charger is switched from OFF to ON, the Green-Yellow-Red LEDs indicate in sequence showing the battery charger self test. After this sequence, which takes two seconds in total, if the battery is connected the red charging LED will come On, indicating the start of charge. If there is no battery connected, the yellow LED will flash briefly once each second, to indicate that the AC power to the charger is connected.

NOTE: THE CHARGER WILL NOW SWITCH ON AND THE YELLOW LED WILL LIGHT.

4. The charger will now commence to charge the battery, as indicated by the RED charging LED's. NOTE: The length of time the charger remains in the "Charging Mode" depends on the size and state of discharge of the battery. This is controlled by the charger's solid state circuitry which constantly monitors the state of the battery and provides the correct charge automatically.

IMPORTANT: The charger must be allowed to go through the complete charge routine in order to obtain the optimum charge.

This will take a minimum of two hours.

5. When the GREEN "READY" LED comes ON, the battery is ready for use. NOTE: The battery may be connected to the charger in the "READY" mode indefinitely, in order to maintain the battery in a fully charged state while not in use without risk of over charging. IMPORTANT: The charger must be disconnected from the 120 volt power supply and switched off before disconnecting from the battery to prevent the possibility of arcing.

SPECIAL NOTE

6. During charging, the current flowing into the battery is indicated by the LED Amp Meter. At the start of charge, if the battery is normally discharged, all 4 RED LED's will be on, and will go out in sequence as the charge current drops. When the last RED LED goes off, the internal proportional timer will start, the GREEN LED will show proportional to the time of the constant current time. ($T/2+1$ hr)
7. If the battery voltage is less than half a volt, the battery is considered very heavily discharged. In this case, the YELLOW charging LED will NOT show.

TROUBLESHOOTING GUIDE

YELLOW CHARGE LIGHT DOES NOT SWITCH ON;

The charger will not commence charging unless properly connected.

1. Check to ensure the charger is connected correctly – BLACK

lead to NEGATIVE (-) terminal and RED lead to POSITIVE (+) terminal or that the Factory installed OEM (Original Equipment Manufacturer) custom connector is properly installed regarding the Polarity at the connectors contact terminals or at the mating connector on the battery or equipment.

2. Check that the clips made a good connection to the battery posts. Twist clips or clean battery posts to ensure good connection.

GREEN READY LIGHT DOES NOT APPEAR AFTER 18 HOURS;

3. The Microprocessor Control can indicate a problem with the battery. If the battery has not reached the First Stage of the Operation within 18 hours, the charger may determine that a problem exists within the battery or the battery is too big for the charger's output rating.

The **OVERRIDE TIMER FUNCTION** is shown by the **GREEN LED FLASHING**.

SERIES AND PARALLEL CHARGING

1. Two 6 volt batteries may be charged with the charger if they are connected in **SERIES** as shown below:

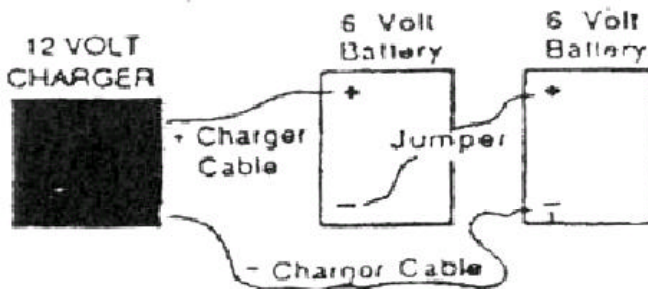

CAUTION: NEVER UNDER ANY CIRCUMSTANCES ATTEMPT TO CHARGE A SINGLE 6 VOLT BATTERY WITH THIS CHARGER. THIS WILL RESULT IN SERIOUS DAMAGE TO THE BATTERY AND CREATE A RISK OF EXPLOSION. EXTREME CARE SHOULD BE TAKEN TO CONNECT THE BATTERIES ONLY AS SHOWN ABOVE. IMPROPER CONNECTION CAN RESULT IN EXPLOSION AND SERIOUS INJURY.

3. Two or more 12 volt batteries may be bank charged with the (1) charger if they are connected in parallel as shown .

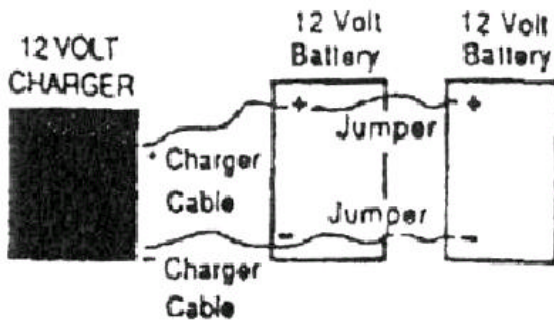

NOTE: It is important that the batteries in the circuit be of the same type (e.g. maintenance free only or conventional lead acid only). Mixing different types of batteries in the same circuit will result in improper charging.

STORAGE INSTRUCTIONS

1. When not in use, store the charger indoors in a cool dry place preferably with its original packing and carton.
2. Place these instructions with the charger during storage.

MAINTENANCE AND CLEANING

Very little maintenance is required other than protecting it from damage and weather.

1. Coil cord when not in use.
2. Clean case and cords with a slightly damp cloth.
3. Corrosion on the clips may be removed with a solution of water and baking soda.
4. Examine cords for damage periodically and replace if necessary with manufacturer approved parts.

SERVICE

This charger is a solid state device and should not require service under normal operating conditions and use according to these instructions. For service call or write the manufacturer.

MOROSO POWER CHARGER BATTERY TYPE SWITCH SETTINGS

NOTE: THIS MODIFICATION IS TO BE PREFORMED BY A MOROSO AUTHORIZED SERVICE TECHNICIAN ONLY. FAILURE TO FOLLOW THESE INSTRUCTIONS WILL EFFECT THE PERFORMANCE OF THE BATTERY, CAUSE THE BATTERY TO GAS AND VOID ANY BATTERY WARRANTY.

WHEN SHIPPED FROM THE FACTORY THE CHARGER IS SET IN THE "NORMAL NODE" UNLESS OTHER WISE SPECIFIED.

BTS (BATTERY TYPE SWITCH) SETTING INSTRUCTIONS
WARNING: DISCONNECT THE A.C. POWER. BATTERY OR LOAD BEFORE SETTING B. T. S. *. FAILURE ¥TO COMPLY MAY RESULT IN SHOCK OR ELECTROCUTION.

WITH A SMALL PLASTIC NON-CONDUCTIVE PROBE. ENTER THROUGH THE TOP FRONT VENT SLOT, SETTING THE CHARGERS "RED" B.T.S. (BATTERY TYPE SWITCH) TO THE CORRESPONDING ACTUATOR POSITION SHOWN BELOW. CHARGER WILL NOW AUTOMATICALLY FUNCTION PER THE B. T. S. SELECTED CHARGING SPECIFICATIONS. NO OTHER ADJUSTMENTS ARE REQUIRED!"

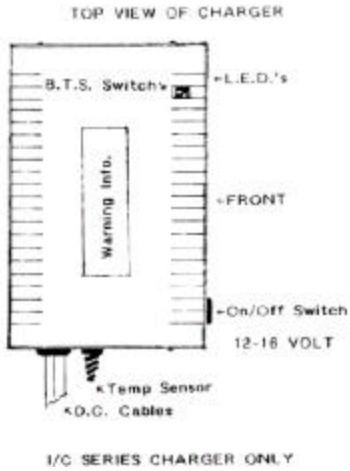

MOROSO PS & ICS CHARGERS BATTERY TYPE SWITCH SETTINGS

NOTE: Voltages shown are for 12 volt chargers. Double voltages for 24 volt



NORMAL MODE
 FOR SEALED LEAD ACID, AGM OR
 EQUIPMENT USED IN CYCLIC OR STANDBY
 Charge - 14.50 VOLTS



GEL CELL MODE
 FOR SEALED GEL CELL OR MINIMAL GAS
 EMISSION
 CHARGE 14.10 VOLTS
 FLOAT 13.85 VOLTS



LIQUID ELECTROLYTE MODE
 FOR VENTED LIQUID ACID OR
 FAST CHARGING FOR CYCLIC USE
 CHARGE - 15.70 VOLTS
 FLOAT - 13.85 VOLTS

Special "BTS" (Battery Type Switch) FEATURE

Power Chargers are fitted with a Dealer settable BTS (Battery Type Switch). The charging circuitry will work correctly with Sealed, Gelled or Flooded type batteries.

Only an Authorized Service Technician is authorized to Change the charger battery type setting. NOTE: Failure to Select The correct setting will affect the performance of the battery, and may cause the battery to gas and void any Warranty on the Battery. If Battery Type is not specified the charger will be supplied set to the NORMAL mode which will provide good performance with most Battery Types and applications.

The BTS is NOT intended for consumer use, If your Dealer or Authorized Service Technician is unable to offer you this Service, contact the Factory for assistance.

**MOROSO PERFORMANCE PRODUCTS, INC.
80 Carter Drive. Guilford, Connecticut 06437-2116**

All Moroso products are manufactured under strict quality control specifications to insure you the finest products available. We rarely receive complaints but should you encounter a problem. Please refer to this Quality Control Number in your correspondence. We must have the Q.C. Number to properly process the complaint.

STATEMENT OF LIMITED WARRANTY

This limited warranty is extended only to each individual who purchases a Moroso product. This limited warranty applies to any product which, after inspection by Moroso Performance Products, is found to have a defect in either material or workmanship. To obtain the benefit of this limited warranty you must (1) return the product and sales receipt to Moroso Performance Products, at your own expense, to the above address so that it is received by Moroso no later than ninety (90) days after the date it was purchased; and (2) clearly state the specific complaint that you have with respect to the product. If all of the above procedures are followed, and the product is found by Moroso to be defective in either material or workmanship, Moroso shall either repair or replace the product at its election, and at its sole cost. Moroso will attempt to repair or replace any defective product within SIXTY (60) days after receipt.

This limited warranty DOES NOT cover or apply to any damage sustained to the engine or other parts which may have been caused by the defective product and DOES NOT cover or apply to any personal injury, labor charges or any other incidental costs or damages caused by the defective product.

THIS LIMITED WARRANTY IS THE ONLY EXPRESS WARRANTY WHICH APPLIES TO MOROSO PRODUCTS AND IS EXPRESSLY GIVEN IN LIEU OF ANY OTHER WARRANTY EXPRESSED OR IMPLIED. INCLUDING THAT OF MERCHANTABILITY. ANY IMPLIED WARRANTY INCLUDING THAT OF MERCHANTABILITY AND/OR FITNESS FOR A PARTICULAR PURPOSE IS HEREBY LIMITED BY THE SAME TERMS AND TIME LIMITATIONS SET FORTH IN THIS LIMITED EXPRESS WARRANTY AND OTHERWISE EXCLUDED. You may have rights under either state or federal law, including laws governing warranties which you should consult.

EXCEPT FOR THOSE OBLIGATIONS ASSUMED HEREIN, MOROSO PERFORMANCE PRODUCTS, INC. ASSUMES NO OTHER OBLIGATIONS IN CONNECTION WITH THE SALE OF ITS PRODUCTS.

Moroso Main Telephone: 203-453-6571 TECH: 203-458-0542

MODEL: Volt _____ Amp _____ SERIAL # _____

(record here for your records)