



Toyota Drag Race Oil Pan and Windage Tray P/N 20930 INSTRUCTIONS

These instructions are a basic guideline and some descriptions may not apply to all vehicles. Always consult the proper Service Manual for complete instructions.

1. Make sure vehicle is in Park and on a level surface, emergency brake on, chock wheels and jack up vehicle, use approved jack stands for safety. Or, put car safely on a lift.
2. Thoroughly clean your new Moroso oil pan and windage tray.
3. Drain oil from pan, remove dipstick and all oil pan bolts. Remove oil pan. Scrape all old gasket material from engine surface. (It may be necessary to unbolt the motor mounts and elevate the engine to remove the oil pan).
4. Remove the oil pump.
5. Loosen the #1 and #5 main cap bolts, 1/4 turn at a time to avoid damage to the caps. Remove the bolts.
6. Install the Moroso windage tray with the notch toward the oil pump mount, (refer to diagram A on back). Replace the main cap bolts and torque to 43 ft. lbs., tighten in 3 steps. Tighten in numbered sequence shown in diagram A. Check the clearance of the connecting rods and crankshaft. It may be necessary to relieve the tray when using some stroker crank and rod combinations. Set the clearance at .060" for steel connecting rods, or .080" - .100" for aluminum connecting rods.
7. Install the oil pump, making sure that the pump shaft properly engages the distributor gear. Rotate the pump assembly counterclockwise as far as the mounting bolt will allow and torque to 15 ft. lbs., this will increase oil pump pickup clearance to the rear of the oil pan. Check oil pump pickup clearance with Moroso oil pan.
8. Install a new cork gasket to the oil pan rail using Silicone RTV or an equivalent to hold gasket firmly in place. (Due to tight internal clearances, a cork gasket must be used).
9. Install the new oil pan by gently sliding it around the pickup and seating it on the block rail. Apply Loctite or equivalent to supplied oil pan studs, thread into engine block 1/4" to 3/8" deep. When all studs are in place, install nuts and tighten in an X-pattern starting from the center outwards. Torque nuts to 4-6 ft. lbs., (48-72 in. lbs.)
10. This pan is equipped with 2 magnetic drain plugs, 1/2" NPT bung for an oil temp. sending unit, and a 1/2" NPT bung for turbo return line, (refer to diagram B on back). Plumb the turbo return with -10AN hose minimum. Plug any of these openings if not being used. Do not overtighten.
11. Replace dipstick, refill with fresh oil and check for leaks. The new Moroso oil pan holds 5.5 quarts, not including the oil filter.

Diagram A

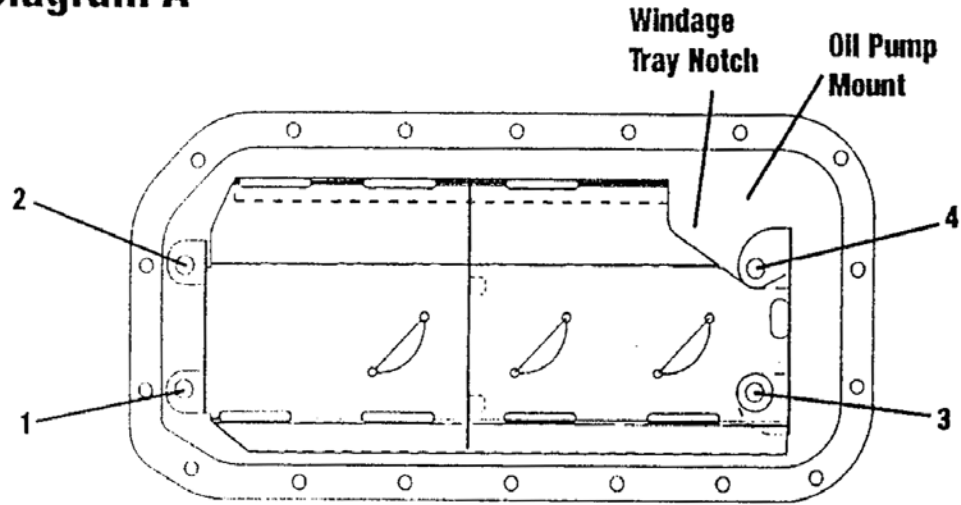
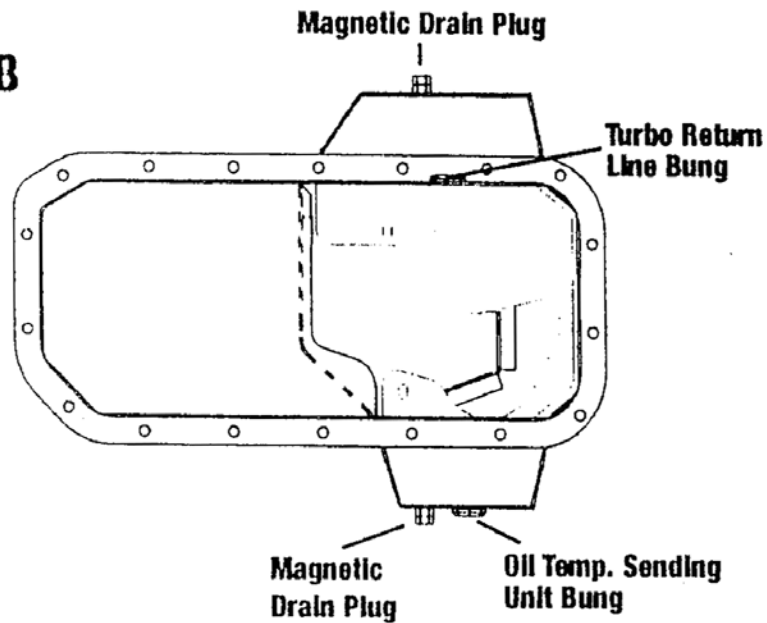

Diagram B



**For Technical Assistance, Call Moroso's Tech Line at
(203) 458-0542, 8:30am – 5:00pm Eastern Time**

MOROSO PERFORMANCE PRODUCTS, INC
80 CARTER DR • GUILFORD, CT 06437-2116
Phone: (203) 453-6571 • Fax: (203) 453-6906