

Please read and save these instructions. Read through this owner's manual carefully before using product. Protect yourself and others by observing all safety information, warnings, and cautions. Failure to comply with instructions could result in personal injury and/or damage to product or property. Please retain instructions for future reference.



## ROTARY TOOL

### FOR CUSTOMER SERVICE

Technical Question?

**CALL 1-866-458-2472**  
**customerservice@oem-tools.com**

### UNPACKING

After unpacking unit, inspect carefully for any damage that may have occurred during transit. Check for loose, missing, or damaged parts. If any damage is observed, a shipping damage claim must be filed with carrier. DO NOT use the OEMTOOLS™ Rotary Tool if broken, bent, cracked or damaged parts (including labels) are noted. Any Rotary Tool that appears damaged in any way, operates abnormally, or is missing parts should be removed from service immediately. If you suspect that the Rotary Tool was subjected to shock load (a load that was dropped suddenly, unexpectedly, etc.), immediately discontinue use until it has been checked by a factory authorized service center.



### **⚠** WARNING

The following safety information is provided as a guideline to help you operate your Rotary Tool under the safest possible conditions. Any tool or piece of equipment can be potentially dangerous to use when safety or safe handling instructions are not known or not followed. The following safety instructions are to provide the user with the information necessary for safe use and operation. Please read and retain these instructions for the continued safe use of your tool. Failure to follow instructions listed below may result in serious injury. In addition, make certain that anyone who uses the equipment understands and follows these safety instructions as well.

### Explanation of Safety Signal Words

**⚠WARNING:** Indicates a potentially hazardous situation which, if not avoided, could result in death or serious injury.

**⚠CAUTION:** Indicates a potentially hazardous situation which, if not avoided, may result in minor or moderate injury.

**CAUTION:** Used without the safety alert symbol indicates a potentially hazardous situation which, if not avoided, may result in property damage.

**NOTES:** Provide clarity and helpful information.

Thank you very much for choosing an OEMTOOLS™ Product!

For future reference, please register your new tool at [www.oem-tools.com](http://www.oem-tools.com) and complete the owner's record below:

Model: \_\_\_\_\_ Purchase Date: \_\_\_\_\_

Save the receipt, warranty and these instructions. It is important that you read the entire manual to become familiar with this product before you begin using it. This product is designed for certain applications only. OEMTOOLS™ cannot be responsible for issues arising from modification. We strongly recommend this product is not modified and/or used for any application other than that for which it was designed. If you have any questions relative to a particular application, DO NOT use the product until you have first contacted customer service to determine if it can or should be performed on the product.



## ROTARY TOOL

### POWER TOOL SAFETY

**▲WARNING:** Read all safety warnings and instructions. Failure to follow the warnings and instructions may result in electric shock, fire, and/or serious injury. Save all warnings and instructions for future reference.

### WORK AREA SAFETY

1. Keep work area clean and well lit. Cluttered or dark areas invite accidents.
2. DO NOT operate power tools in explosive atmospheres, such as in the presence of flammable liquids, gases or dust. Power tools create sparks which may ignite the dust or fumes.
3. Keep children and bystanders away while operating a power tool. Distractions can cause you to lose control.

### ELECTRICAL SAFETY

1. Power tool plugs must match the outlet. Never modify the plug in any way. DO NOT use any adapter plugs with earthed (grounded) power tools. Unmodified plugs and matching outlets will reduce risk of electric shock. Avoid body contact with earthed or grounded surfaces such as pipes, radiators, ranges and refrigerators. There is an increased risk of electric shock if your body is earthed or grounded.
2. DO NOT expose power tools to rain or wet conditions. Water entering a power tool will increase the risk of electric shock.
3. DO NOT abuse the cord. Never use the cord for carrying, pulling or unplugging the power tool. Keep cord away from heat, oil, sharp edges or moving parts. Damaged or entangled cords increase the risk of electric shock.
4. When operating a power tool outdoors, use an extension cord suitable for outdoor use. Use of a cord suitable for outdoor use reduces the risk of electric shock.
5. If operating a power tool in a damp location is unavoidable, use a residual current device (RCD) protected supply. Use of a ground fault circuit interrupter (GFCI) reduces the risk of electric shock.

### PERSONAL SAFETY

1. Stay alert, watch what you are doing, and use common sense when operating a power tool. DO NOT use a power tool while you are tired or under the influence of drugs, alcohol or medication. A moment of inattention while operating power tools may result in serious personal injury.

2. Use personal protective equipment. Always wear eye protection. Protective equipment such as dust mask, non-skid safety shoes, hard hat, or hearing protection used for appropriate conditions will reduce personal injuries.
3. Prevent unintentional starting. Ensure the switch is in the off-position before connecting to power source and/or battery pack, picking up or carrying the tool. Carrying power tools with your finger on the switch or energizing power tools that have the switch on invites accidents.
4. Remove any adjusting key or wrench before turning the power tool on. A wrench or a key left attached to a rotating part of the power tool may result in personal injury.
5. DO NOT overreach. Keep proper footing and balance at all times. This enables better control of the power tool in unexpected situations.
6. Dress properly. DO NOT wear loose clothing or jewelry. Keep your hair, clothing and gloves away from moving parts. Loose clothes, jewelry or long hair can be caught in moving parts.
7. If devices are provided for the connection of dust extraction and collection facilities, ensure these are connected and properly used. Use of dust collection can reduce dust-related hazards.

### POWER TOOL USE AND CARE

1. DO NOT force the power tool. Use the correct power tool for your application. The correct power tool will do the job better and safer at the rate for which it was designed.
2. DO NOT use the power tool if the switch does not turn it on and off. Any power tool that cannot be controlled with the switch is dangerous and must be repaired.
3. Disconnect the plug from the power source and/or the battery pack from the power tool before making any adjustments, changing accessories, or storing power tools. Such preventive safety measures reduce the risk of starting the power tool accidentally.
4. Store idle power tools out of the reach of children and DO NOT allow persons unfamiliar with the power tool or these instructions to operate the power tool. Power tools are dangerous in the hands of untrained users.
5. Maintain power tools. Check for misalignment or binding of moving parts, breakage of parts, and any other condition that may affect the power tool's operation. If damaged, have the power tool repaired before use. Many accidents are caused by poorly maintained power tools.



## ROTARY TOOL

6. Keep cutting tools sharp and clean. Properly maintained cutting tools with sharp cutting edges are less likely to bind and are easier to control.
7. Use the power tool, accessories and tool bits, etc. in accordance with these instructions, taking into account the working conditions and the work to be performed. Use of the power tool for operations different from those intended could result in a hazardous situation.
8. Hold power tools by insulated gripping surfaces when performing an operation where the cutting tool may contact hidden wiring or its own cord. Contact with a "live" wire will make exposed metal parts of the tool "live" and shock the operator.

### SERVICE

Have your power tool serviced by a qualified repair person using only identical replacement parts. This will ensure that the safety of the power tool is maintained.

### ▲WARNING:

- Disconnect the plug from the power source before making any adjustments, changing accessories or storing the tool.
- To avoid electrical hazards, fire hazards or damage to the Rotary Tool, use proper circuit protection.
- DO NOT abuse the cord. Never use the cord to carry the tools or pull the plug from an outlet. Keep cord away from heat, oil, sharp edges or moving parts. Replace damaged cords immediately.

**▲WARNING:** Carefully read Rules for Safe Operation and Instructions.

### IMPORTANT SAFETY INSTRUCTIONS

The warnings, precautions, and instructions discussed in this manual cannot cover all possible conditions and situations that may occur. The operator must understand that common sense and caution are factors which cannot be built into this product, but must be supplied by the operator.

### SPECIFIC SAFETY RULES

1. Hold the tool by its insulated gripping surfaces when performing an operation where the cutting tool may contact hidden wiring or its own cord. Contact with a "live" wire will make exposed metal parts of the tool "live" and shock the operator.
2. Always make sure the work surface is free from nails and other foreign objects. Cutting into a nail can cause the bit and the tool to jump and damage the bit.
3. Never hold the workpiece in one hand and the tool in the other hand when in use. Never place your hands near or below the cutting surface. Clamping the material and guiding the tool with both hands is much safer.
4. Never lay the workpiece on hard surfaces like concrete, stone, etc. The protruding cutting bit may cause tool to jump.
5. Always wear safety goggles and a dust mask. Use only in well-ventilated areas. Using personal safety devices and working in a safe environment reduces risk of injury.
6. After changing the bits and accessories or making adjustments, make sure the collet nut and any other adjustment devices are securely tightened. Loose adjustment devices will be violently thrown.
7. Always use the correct collet size. If the collet size is larger than the accessory shank size, it will not grip the shank properly, leading to possible injury to the operator or damage to the tool.
8. Always check accessory bits, grinding stones, cut-off wheels, etc. for damage before each use. Damaged accessories can break during use and cause serious injury.
9. Never use dull or damaged bits. Sharp bits must be handled with care. Damaged bits can snap during use. Dull bits require more force to push the tool, possibly causing the bit to break.
10. Never touch the bit during or immediately after use. After use, the bit is too hot to be touched by bare hands.

### DISPOSAL

At the end of the useful life of the OEMTOOLS™ Rotary Tool, dispose of the components according to all state, federal, and local regulations.



## ROTARY TOOL

### PURPOSE

The OEMTOOLS™ Rotary Tool with 35 Piece Accessory Kit polishes, grinds, cuts, shapes, and sands metals and is great for home hobbyists or garage machinists, whether professional or novice. All tools needed are at hand and it accepts all standard accessories and attachments.

### PRODUCT SPECIFICATIONS

<b>Voltage:</b>	120V/60Hz
<b>Input Power:</b>	1.2 Amp
<b>No-Load Speed:</b>	10,000-35,000 RPM
<b>Collet Capacity:</b>	1/8" and 3/32"
<b>Spindle Lock:</b>	Yes
<b>Cord Length:</b>	6 Ft.

**⚠WARNING:** Double insulated tools are equipped with a polarized plug (one blade is wider than the other). This plug will fit in a polarized plug only one way. If the plug does not fit fully in the outlet, reverse the plug. If it still does not fit, contact a qualified electrician to install a polarized outlet. **DO NOT** change the plug in any way. Double insulation eliminates the need for the three-wire grounded power cord and grounded power supply system.

### OPERATING INSTRUCTIONS

**⚠WARNING:** Be sure you read, understand and apply safety instructions before use.

- Always inspect, maintain and operate in accordance with ANSI safety code for power tools and other local safety codes and regulations.
- Use clamps or other practical ways to secure and support the workpiece to a stable platform.
- DO NOT** force the tool. Use the correct tool for the job.
- Disconnect the plug from the power source before making any adjustments, changing accessories or storing the tool.
- Check for misalignment or binding moving parts, breakage of parts and any other condition that may affect the tool's operation. If damaged, have the tool serviced before using.
- Use only accessories that are recommended by the manufacturer for your model.
- Hold tool by insulated gripping surfaces when performing an operation where the cutting tool may contact hidden wiring or its own cord.
- Always make sure the work surface is free from nails and other foreign objects.
- Never hold the workpiece in one hand and the tool in the other hand when in use. Never place the hands near or below the cutting surface.
- Never lay workpiece on hard surfaces like concrete, stone, etc.
- After changing the bits and accessories or making adjustments, make sure the collet nut and any other adjustment devices are securely tightened.
- Always wear safety goggles and a dust mask. Use only in well-ventilated areas. Using personal safety devices and working in a safe environment reduces risk of injury.
- Always use the correct collet size.
- Always check accessory bits, grinding stones, cut-off wheels, etc. for damage before each use.
- Never use dull or damaged bits. Sharp bits must be handled with care.
- Never touch the bit during or immediately after use.
- The Rotary Tool is wired at the factory for 110–120V operation. It must be connected to a 110–120V, 15A time delayed fuse or circuit breaker. To avoid shock or fire, replace power cord immediately if it is worn, cut or damaged in any way.
- Avoid accidental starting. Be sure switch is OFF before plugging in.
- Remove adjusting keys or wrenches before turning the tool ON.

**NOTE:** Most commonly used bits and accessories with 1/8" and 3/32" shanks will fit this tool. Rotary Tool accessories, such as a drill press designed for other Rotary Tools, may not fit this tool.

**⚠WARNING:** If any part is missing or damaged, do not plug the Rotary Tool into the power source until the missing or damaged part is replaced.

**⚠WARNING:** To avoid fire or toxic reaction, never use gasoline, naphtha, acetone, lacquer thinner or similar highly volatile solvents to clean the tool.



# ROTARY TOOL

## ASSEMBLY AND OPERATION SPEED SELECTION

Set Rotary Tool speed by rotating the variable speed control dial (1) to the appropriate speed (see Fig.1). Position the speed control dial at "1" for slowest speed, "3" for medium speed and at "MAX" for the highest speed.

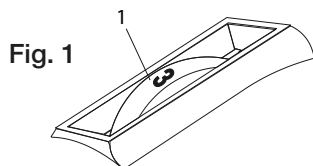

## ON/OFF SWITCH

To turn the switch ON, push on the lower part of the ON/OFF switch #1 in Fig. 2. To turn the switch OFF, push on the upper part of the ON/OFF switch #2 in Fig. 2.

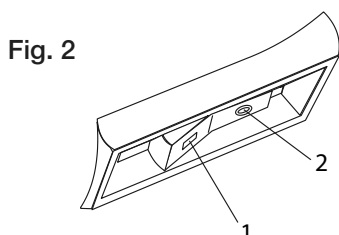

## CHANGING THE COLLET

Some accessories require the use of different sized collets. Collet sizes can be 1/16", 3/32" and 1/8". It is important to ensure that the collet size matches the accessory.

**NOTE:** This tool includes two of the most commonly used collets: 3/32" and 1/8".

**⚠WARNING:** Using a collet that is too large for the accessory will result in the accessory possibly being thrown from the tool, causing serious injury.

1. Turn the tool switch OFF and remove the plug from the power source.
2. Depress the spindle lock button (1) and slowly turn the collet nut (2) until the spindle lock button locks the spindle (see Fig. 3).
3. While holding the spindle lock button down, turn the collet nut counterclockwise until it is removed.
4. Remove the collet (3) by pulling it out of the spindle (4).

5. Insert the replacement collet into the spindle and replace the collet nut by turning it clockwise while holding the spindle lock button down.

**NOTE:** DO NOT tighten the collet nut without an accessory installed in the collet. You will damage the collet.

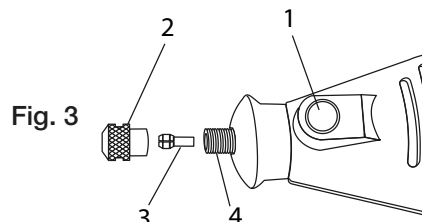

## INSTALLING ACCESSORIES

1. Turn the switch OFF and disconnect the tool from the power source.
2. Depress the spindle lock button (1) and slowly turn the collet nut (2) until the spindle lock button locks the spindle.
3. While holding the spindle lock button down, turn the collet nut counterclockwise until the collet is loose inside the collet nut.

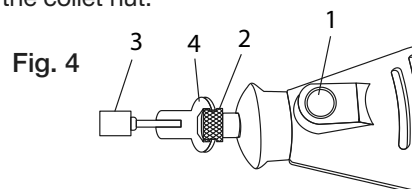

4. Insert accessory (3) into collet.

**NOTE:** Make sure the correct collet is used for the accessory. If collet is too large, replace the collet with the next smaller size.

5. Insert accessory at least 3/4" into the collet.
  6. Press the spindle lock button and engage it in the spindle. While holding the spindle lock button down, hand tighten the collet by turning it clockwise.
- NOTE:** DO NOT use pliers to tighten the collet nut. Use the small wrench (4) supplied. Over-tightening will cause damage to the tool.
7. Pull on the accessory to ensure it is securely in place.



# ROTARY TOOL

## SELECTING PROPER SPEEDS

Different speeds are required depending upon the type of operation being performed. The following chart outlines those basic speeds:

Operation	Speed
Cutting Metal	5 – MAX
Sanding Wood	5 – MAX
Cutting Hard Metal	5 – MAX
Engraving Metal	4 – 5
Deburring	4 – 5
Drilling Holes	4 – 5
Removing Rust	3 – 4
Sharpening	3 – 4
Polishing	1 – 2



This symbol designates that this tool is listed with U.S. requirements by ETL Testing Laboratories, Inc. and conforms to UL Std. 60745-1, 60745-2-3

## ACCESSORY KIT CONTENTS

Illustration	Description	Shape	Qty
	Aluminum oxide grinding stone	Cylinder 3/8"	1
	Aluminum oxide grinding stone	Cone 5/8"	1
	Aluminum oxide grinding stone	Parabolic 3/8"	1
	Aluminum oxide grinding stone	Cylinder 13/32"	1
	Aluminum oxide grinding stone	Cylinder 25/32"	1
	Felt polishing wheel	1/2"	2
	Felt polishing wheel	1"	2
	Mandrel	1/8" for felt polishing wheels	1
	Bristle brush	3/4" radial	1
	Sanding band	1/2" 60-grit	3
	Drum sander	1/2" with 1/8" shank	1
	Sanding disc	3/4" 60-grit	3
	Heavy-duty Cut-off wheel	15/16" x 0.031"	6
	Regular-duty cut-off wheel	15/16" x 0.025"	6
	Screw mandrel	1/8" for sanding discs, cut-off wheels, cloth wheels & grinding wheels	1
	Dressing stone	3/8" x 1" square	1
	Collet	1/8" (packed in tool)	1
	Collet	3/32"	1
	Wrench	For collet nut, drum sander & screw mandrel	1



# ROTARY TOOL

## PARTS LIST

Item #	Description	Quantity
1	Screw	6
2	Left Enclosure	1
3	Screw	2
4	Cord Clamp	1
5	Cord Guard	1
6	Power Plug	1
7	Variable Speed PCB	1
8	Stator	1
9	Bearing Sleeve	1
10	Bearing 606-2Z	1
11	Carbon Brush	2
12	Carbon Brush Cap	2
13	Brush Holder	2
14	Brush Holder Support	2

Item #	Description	Quantity
15	Rotor	1
16	Fan	1
17	Bearing 626-2Z	1
18	Output Shaft	1
19	Collet	1
20	Collet Nut	1
21	Head Nut	1
22	Shaft Lock Spring	1
23	Shaft Locking Pin	1
24	Shaft Lock Button	1
25	Switch	1
26	Right Enclosure	1
27	Hook	1

## PARTS DIAGRAM

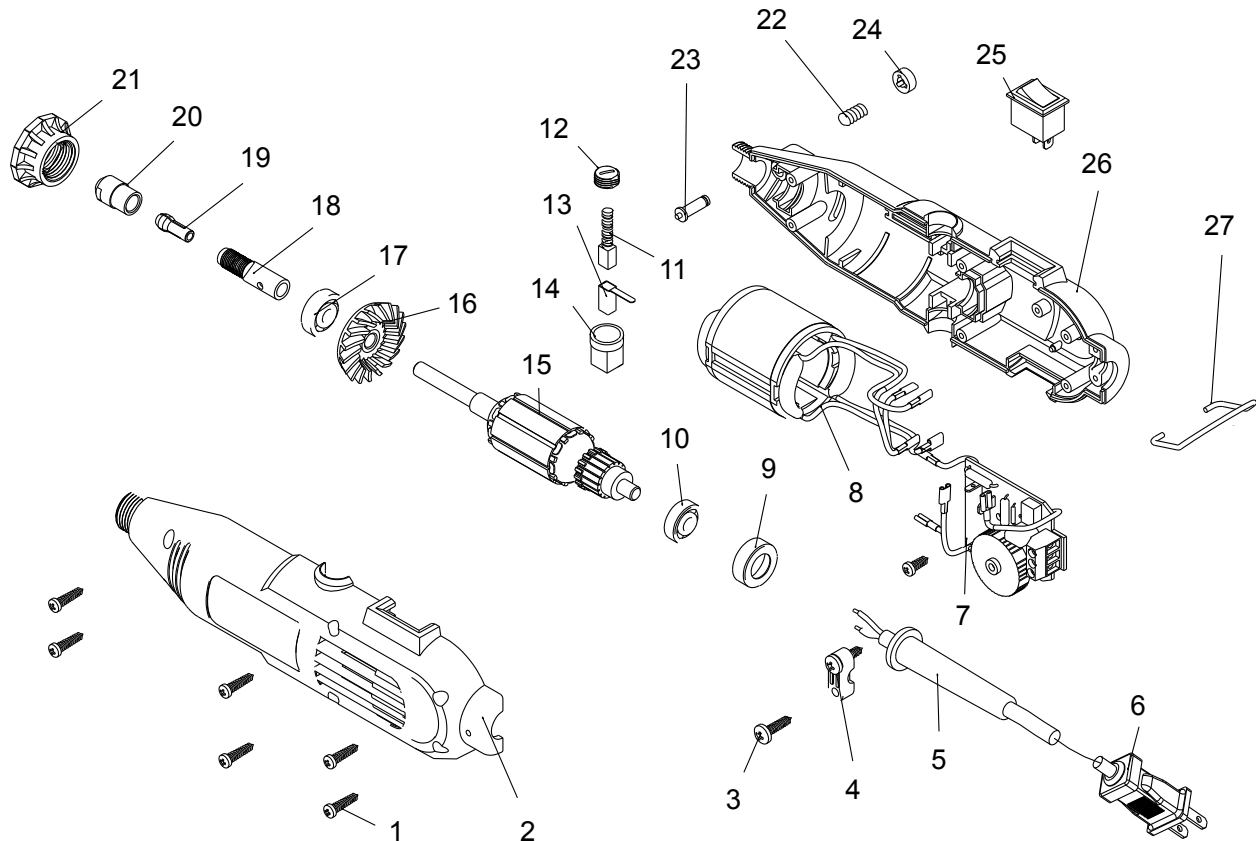

### NOTE:

Not all components of the Rotary Tool are replacement items, but are illustrated as a convenient reference for location and position in the assembly sequence.



## ROTARY TOOL

### OEMTOOLS™ ONE YEAR WARRANTY

For up to one year from the date of purchase of this OEMTOOLS™ product, if you find any defect in material or workmanship (through normal usage), return it to the place of purchase or to OEMTOOLS™ for repair or replacement at our discretion. In order to obtain this service, send the product and proof of purchase (transportation pre-paid) to:

OEMTOOLS™ Q.A. Dept, 3580 E. Raines Road #3, Memphis, TN 38118.

We will not be responsible for lost or damaged goods during transportation; please insure your package. If our inspection verifies the defect, we will either repair or replace the product, or we may elect to refund the purchase price if we cannot readily and quickly provide you with a replacement. We will return repaired products at our expense, but if we determine there is no defect, or that the defect resulted from causes not within the scope of our warranty, then you must bear the cost of returning the product.

OEMTOOLS™ does not provide warranty for products labeled other than OEM® or OEMTOOLS™. OEMTOOLS™ will not provide any warranty for products subjected to abnormal use. Abnormal use includes (but is not limited to) abuse, accident, alteration, neglect, and unauthorized or unreasonable use or repairs. This warranty does not cover bits, blades, files, batteries, or calibration. We recommend that you maintain your tools and sharpen or replace blades, bits, files, and batteries as necessary. OEMTOOLS™ reserves the right to make any changes in construction or design at any time without any obligation in incorporating such changes to tools or equipment previously sold. OEMTOOLS™ makes every effort to ensure that its products meet high quality and durability standards, and warrants to the original purchaser that this product is free from defects in materials and workmanship for the period of one year from the date of purchase. This warranty does not apply to damage due directly or indirectly to misuse, abuse, negligence or accidents, repairs or alterations outside our facilities, criminal activity, improper installation, normal wear and tear, or to lack of maintenance.

We shall in no event be liable for death, injuries to persons or property, or for incidental, contingent, special or consequential damages arising from the use of our product. Some states DO NOT allow the exclusion or limitation of incidental or consequential damages, so the above limitation of exclusion may not apply to you. THIS WARRANTY IS EXPRESSLY IN LIEU OF ALL OTHER WARRANTIES, EXPRESS OR IMPLIED, INCLUDING THE WARRANTIES OF MERCHANTABILITY AND FITNESS. This warranty gives you specific legal rights, and you may also have other rights, which vary from state to state.

Don't forget to register your new OEMTOOLS™ product at [www.oem-tools.com](http://www.oem-tools.com).

## CONTACT US

3580 E. Raines Road, Suite 3, Memphis, TN 38118  
Tel: 1-866-458-2472  
[www.oem-tools.com](http://www.oem-tools.com)