

182855

09-14 FORD F150 (INCLUDES RAPTOR)
ROOF LIGHT BAR BRACKET KIT (50" RIGID
STRAIGHT LIGHT)

OFF CAMBER FABRICATIONS

by: **MBRP** INC.

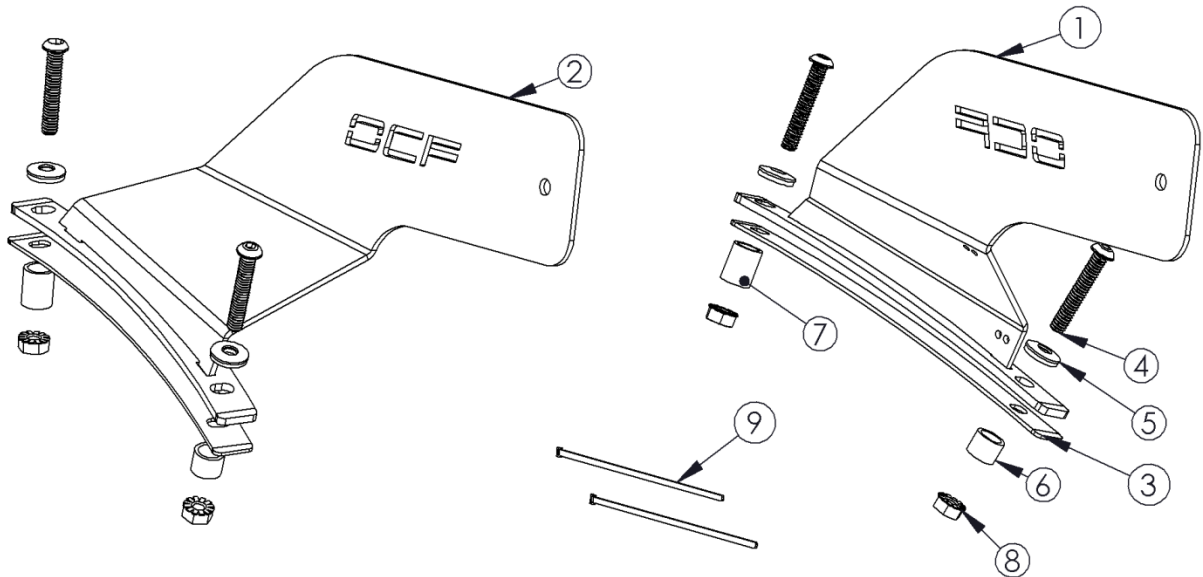

1. DRIVER-SIDE BRACKET
2. PASSENGER-SIDE BRACKET
3. SEAL (2 PCS)
4. 1/4" BUTTON-HEAD HEX BOLT (4 PCS)
5. 1/4" RUBBER-BACKED WASHER (4 PCS)
6. 1/4" SPACER 3/8" L (2 PCS)
7. 1/4" SPACER 5/8" L (2 PCS)
8. 1/4" K-LOCK NUT (4 PCS)
9. CABLE TIE (2 PCS)
10. INSTALLATION TEMPLATE (NOT SHOWN)

PLEASE READ BEFORE STARTING INSTALLATION

While MBRP Inc. has made every effort to ensure that all components of this kit are of superior quality and properly packaged, it is the installer's responsibility to ensure the following before starting:

- that ALL components shown above are present.
- that ALL mating components fit together.
- that there are no damaged components.
- that the kit you have purchased is appropriate for your year and model of vehicle.
- that the kit will not interfere with any modifications previously installed or planned.
- that you have read and understand these instructions.

If you have any questions or are uncertain about any aspect of the installation of this kit on your vehicle please contact your dealer before commencing installation.

Installation of OCF Roof Light Kit



Figure 1



Figure 2



Figure 3



Figure 4

1. Cut out the **Driver-Side Installation Template** and position it on top of the roof gutter adjacent to the windshield. Align the 'Windshield Edge' with the top of the windshield.

Refer to Figure 1.

2. Tape the **Driver-Side Installation Template** back in place (aligned to windshield and centered in the gutter). Use a center punch and hammer to punch the front and rear drilling locations labeled on the template.

Refer to Figure 2.

3. Remove the **Driver-Side Installation Template** and tape the surrounding area to prevent scratching as you drill. Drill pilot holes (1/8") on the punch marks. Slowly work up to a 1/4" hole. There is a second layer of steel also drill through it with the 1/4" drill.

4. Enlarge the top holes to 1/2" to allow the spacers to sit inside the holes. Do not drill through the second layer of sheet metal. The **1/4" Spacer 5/8"L** goes to the rear hole, the shorter **1/4" Spacer 3/8"L** goes toward the windshield. The spacers should sit flush with surrounding roof panel. Repeat steps 1 to 4 on the passenger side.

Refer to Figures 3 & 4.



Figure 5



Figure 6



Figure 7



Figure 8

5. The headliner has to be temporarily lowered or removed to proceed with the next steps, refer to manufacture instructions for removal. **Refer to Figures 11-18.**
6. With the headliner out of the way use the **Inside Pillar Templates** to mark the access holes inside the vehicle on both the sides of the vehicle. Make sure the airbag is not in the way. Temporarily reposition it while marking and drilling. With the templates secured with tape mark the hole locations, two per side. **Refer to Figure 5.**
7. After drilling a pilot hole enlarge it to $\frac{3}{4}$ " using a drill or hole- saw. Be sure to drill only through the bottom layer of steel. **Refer to Figure 6.**
8. Position the **Seal and Driver -Side Bracket** and use the hardware provided to install the **Driver-Side Bracket** .Make sure you to not over tighten the $\frac{1}{4}$ " **Rubber-Backed Washer**. A small amount of sealer on each hole is also recommended. **Refer to Figures 7 & 8.**
9. Repeat step 8 for the **Passenger -Side Bracket** but leave it slightly loose to be able to install the light bar.



Figure 9

10. Install the light bar using the hardware provided by the light bar manufacturer. Tighten the Passenger Side Bracket.

11. *Wire as per light bar instructions.* **Cable Ties** are provided to secure the wire to the **Driver-Side Bracket.**

12. Reinstall the headliner.



Figure 10



Figure 11



Figure 12



Figure 13



Figure 14



Figure 15



Figure 16



Figure 17



Figure 18

Congratulations! You're finished!

We are sure that you will enjoy this **Off Camber Fabrications** product by *MBRP Inc.*