

2004-2010 Ford F-150 CC/EC 4.6/5.4L

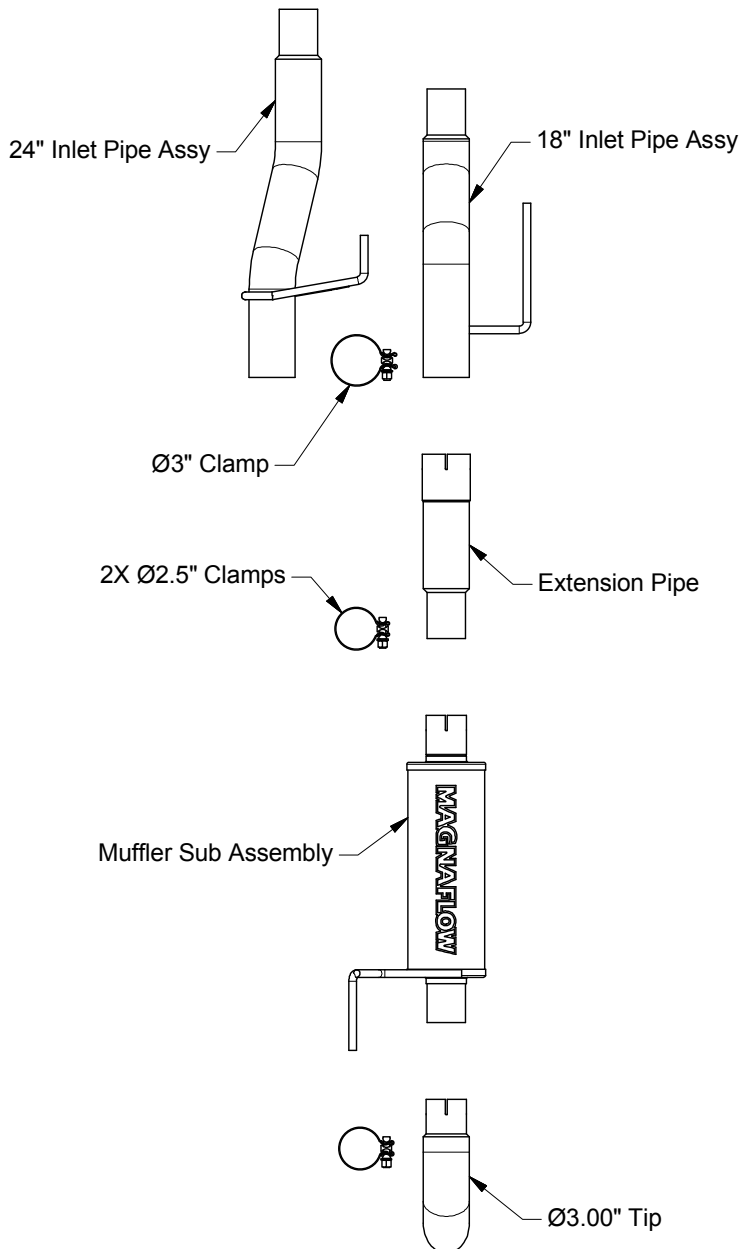

Warning: When working on, under, or around any vehicle exercise caution. Please allow the vehicle's exhaust system to cool before removal, as exhaust system temperatures may cause severe burns. If working without a lift, always consult vehicle manual for correct lifting specifications. Always wear safety glasses and ensure a safe work area. Serious injury or death could occur if safety measures are not followed.

Step 1: (Carefully read all instructions before installation) Unbolt the clamp attaching the OEM muffler inlet to the catalytic converter extension. The OEM system can now be removed by disengaging the welded hangers from the OEM rubber isolators (Do not damage the OEM rubber isolators, as they will be reused to mount the new system.) You may need to cut the tailpipe about 1" behind the muffler to aid in removal.

Step 2: Early 2004 trucks will need to use the 24" long intermediate pipe, and newer models will use the 18" intermediate pipe. Once you've determined which length you need, fasten the inlet-end to the catalytic converter extension using the OEM clamp assembly and by fitting the welded hanger into the OEM rubber insulator, if applicable (Leave all clamps and fasteners loose for final adjustment of the complete system.) Install the extension pipe, muffler sub assembly, and tip in the same fashion using the supplied clamps.

Step 3: With all components mounted loosely, adjust the system for overall aesthetics and clearance of frame & bodywork. (MAGNAFLOW recommends at least 1/2" of clearance between the exhaust system and any body panels to prevent heat-related body damage or fire.)

Step 4: Once a final position has been chosen for the new system, evenly tighten all fasteners from front to rear. The supplied band clamps must be VERY tight to properly align the pipes and prevent leaks (Approximately 65ft-lbs). U-bolt clamps should be tightened to approximately 30-35ft-lbs. Inspect all fasteners after 25-50 miles of operation and retighten if necessary.

**** Magnaflow Performance Exhaust recommends professional installation on all their products**