



QUALITY... PLAIN & SIMPLE®

Transmount Emergency Hand Brake Installation Instructions

Transmount Emergency Hand Brake Installation Instructions

Building American Quality... With A Lifetime Warranty!®

10924 Murdock Dr. • Knoxville, TN 37932

TOLL FREE 1-877-469-7440 • (865) 966-2269 • FAX (865) 671-1999 • tech@lokar.com • www.lokar.com

General Installation Notes:

Please read instructions completely before beginning installation. If you have any questions please call. Before starting installation, scotch vehicle tires to avoid accidental movement of the vehicle. Disconnect negative battery cable before beginning installation.

NOTE: This hand brake is designed specifically for use with a Lokar Transmount Shifter and Lokar Transmount Emergency Brake Cable Kit.

Step 1: Install the Lokar Transmount Shifter before beginning installation of the Emergency Hand Brake.

Step 2: If you are using the Lokar Transmount Emergency Brake Cable Kit, then remove the clevis pin and clevis from the hand brake and discard (Fig. 1). Make sure to keep the 5/16" flat washer and 1/8" x 1/2" cotter pin for use during reassembly. Install the clevis and clevis pin that came with the Lokar Transmount Emergency Brake Cable Kit into the hand brake. Also discard ONE of the supplied 3/4" spacers (you will only need one 3/4" spacer with the Lokar brake cable kit).

If you are **NOT** using the Lokar Transmount Emergency Brake Cable Kit, then the supplied clevis may be modified or replaced as required in order to connect to your existing cables. Make sure to keep the 5/16" flat washer and 1/8" x 1/2" cotter pin for use during reassembly. You will use both of the supplied 3/4" spacers to go between the hand brake and the Lokar shifter mount bracket or your custom bracket. **Fig. 1**

Step 3: The brake cable bracket from the Transmount Emergency Brake Cable Kit will be installed at the same time as the hand brake assembly. Included in the Transmount Emergency Brake Cable Kit there are three 3/8" spacers and one 1/4" spacer to center the hand brake in the brake cable bracket. On the front mounting bolt, install one 3/8" spacer on the right side between the brake cable bracket and the hand brake, and one 3/4" spacer on the left between the hand brake and the shifter mount bracket. On the rear mounting bolt, install one 3/8" spacer on the right between the brake cable bracket and the hand brake; one 3/8" spacer on the left between the hand brake and the brake cable bracket; and one 1/4" spacer between the brake cable bracket and the shifter mount bracket. **Fig. 2**

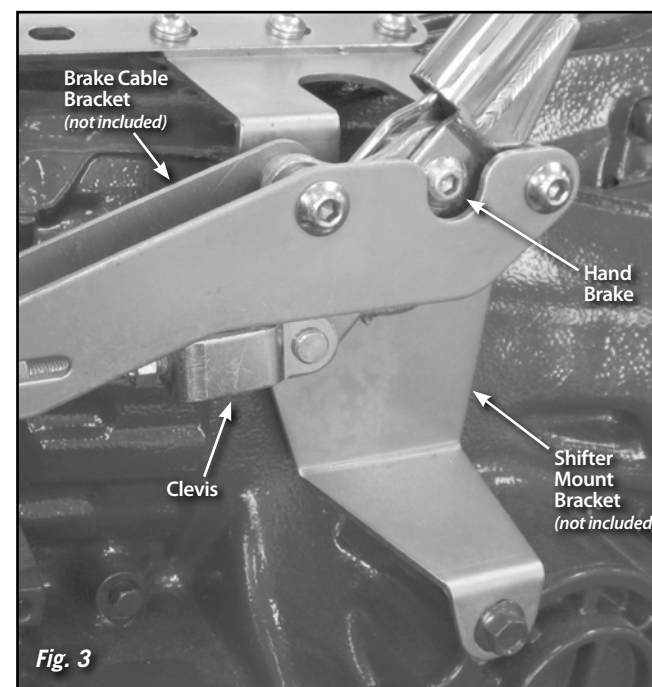
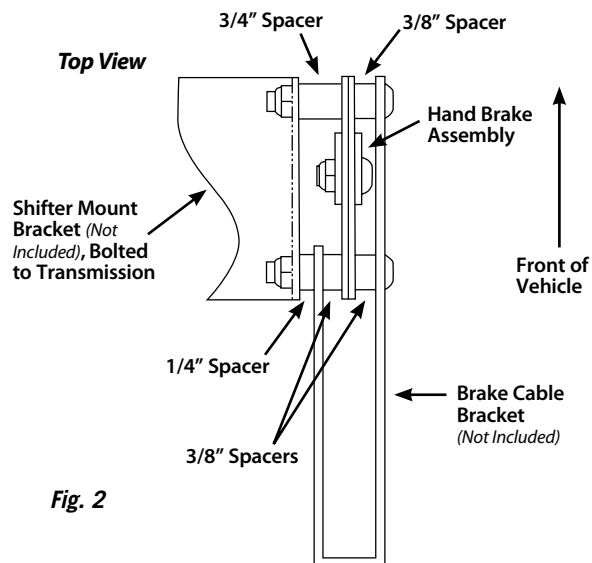
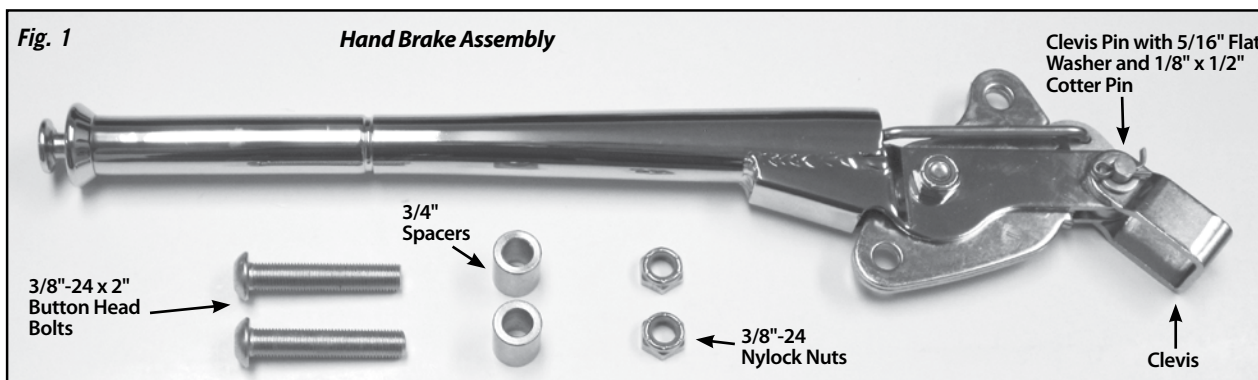

Step 4: Follow the instructions for the Transmount Emergency Brake Cable Kit to connect the emergency brake cables. Adjust the hand brake so that there is no slack, but making sure that the brakes are not applied when the hand brake is released. Generally, you will want the cables adjusted so that three clicks of the hand brake will prevent the vehicle from moving (although your braking system may be different). Your completed installation should look like **Fig. 3**.