



**QUALITY... PLAIN & SIMPLE®**

**Ford Explorer/Internal Wilwood  
Emergency Brake Cable Installation Instructions**

# Ford Explorer/Internal Wilwood Emergency Brake Cable Installation Instructions

Part# EC-81FU, EC-81FHT, EC-81TU & EC-81THT

**Building American Quality... With A Lifetime Warranty!**

10924 Murdock Dr. • Knoxville, TN 37932

TOLL FREE 1-877-469-7440 • (865) 966-2269 • FAX (865) 671-1999 • tech@lokar.com • www.lokar.com

**General Installation Notes:**

Please read instructions completely before beginning installation. If you have any questions please call.

**Recommendation for Aluminum Fittings:**

We recommend that you use an anti-seize lubricant on all aluminum nuts before tightening.

**Emergency Brake Cable Installation**

**Step 1:** Lay out housing the length of vehicle with end fittings toward the rear of vehicle.

**Step 2:** Install backing plate fitting into backing plate bracket with nylock nut supplied in kit. Backing plate bracket is part of brake system. This is not supplied by Lokar.

**Step 3:** Begin to route outer housing up toward the parking brake handle as necessary. (i.e., Lokar Floormount, Transmount or Under-the-Dash Footbrake). Be sure to route neatly away from moving, heated and spinning components of vehicle. Burning or chafing will not allow for a warranted part. Use clamps or mounts to secure housing into place.

**Step 4:** Once you have reached the hand brake assembly, cut outer housing. Slide ferrule supplied in kit into place and slide end of cable housing into the cable housing adjuster. You have now completed the outer housing installation. *(Note: The Under-the-Dash Footbrake requires a connector cable which can be purchased from Lokar).*

**Step 5:** Install stainless Ford Explorer clevis supplied in kit onto inner wire by sliding end of inner wire without the ball through the 1/8" hole from inside U-shaped part of clevis. Pull wire through clevis until the ball on end of inner wire stops inside of clevis.

**Step 6:** Now run end of inner wire without clevis through housing starting at the rear of the vehicle. Run wire until you can hook clevis onto internal brake arm supplied in the brake kit. You will now have excess inner wire at hand brake end of housing. Complete this step for passenger and driver sides.

**Step 7:** Now loosen all four setscrews in cable block and slide each inner wire through holes in cable block. Now, with a pair of pliers, pull one inner wire at a time until you feel tension and tighten setscrews. Adjust cable housing with cable housing adjusters until the emergency brakes work properly. If necessary, set preferred tension on emergency hand brake using the tension adjuster.

**Step 8:** The last step is to cut the excess inner wire coming through the cable block and to check to make sure everything is tight.

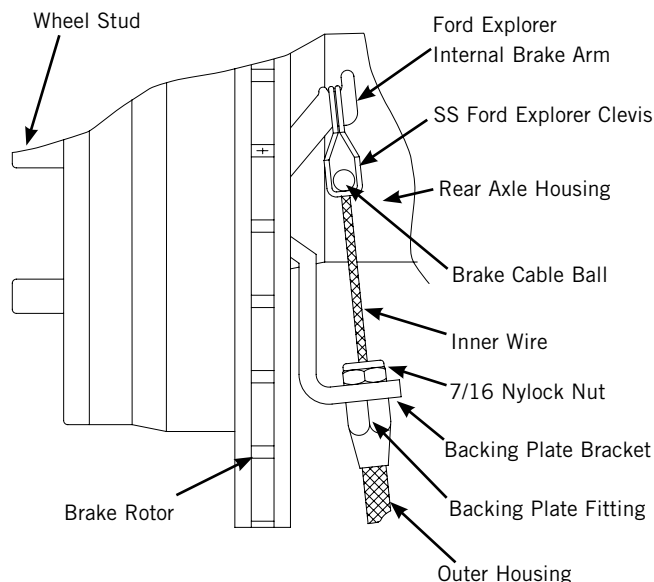

**Top View of Passenger Side**

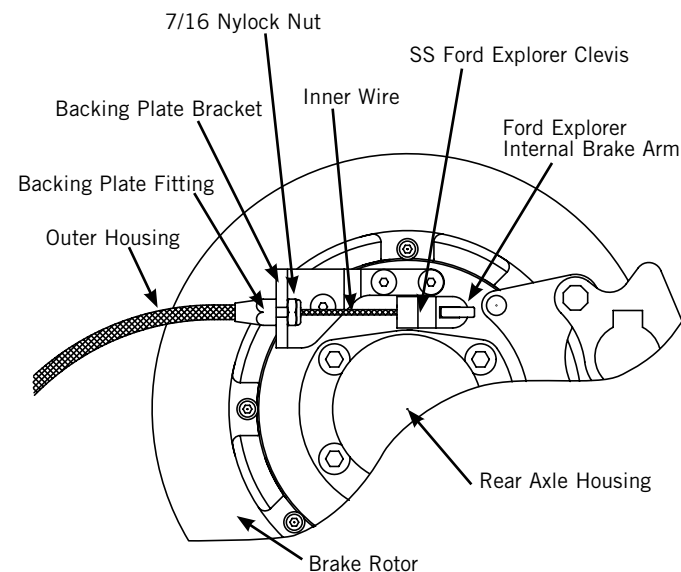

**Side View of Passenger Side**