

Engineered Performance!

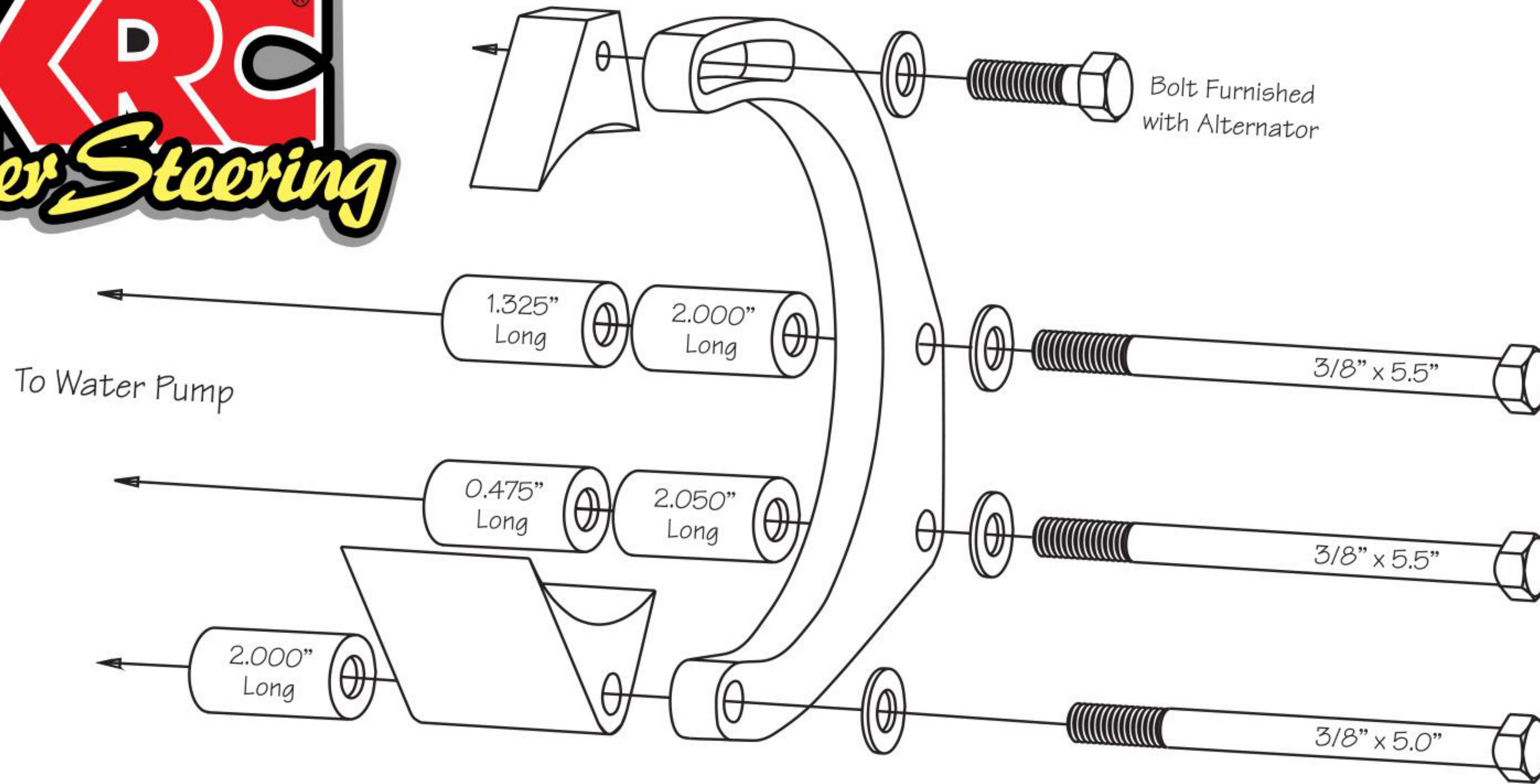

## KRC 40550000 DELCO 2-BOLT 156MM ALTERNATOR BRACKET KIT

Using this exploded view, assemble alternator and mounting kit with all bolts, washers and spacers in their proper position leaving bolts finger tight. First tighten the upper bracket on the water pump, then tighten the two bolts that attach the lower bracket to the block. Adjust belt tension to specifications, then tighten the bolts that pass through the alternator.

**Note:** This kit is designed for our KRC 15101001 water pump with CNC machined mounting bosses, as well as our serpentine pulley sets. You may have to alter the water pump spacing, if a different water pump or pulley set is used, to get proper pulley and belt alignment. Also, mounting bosses on alternators may vary from manufactures. Make sure the pulley is parallel with the block. An optional adapter (KRC 40551000) is required to attach a 156mm 3-bolt alternator to this kit.