

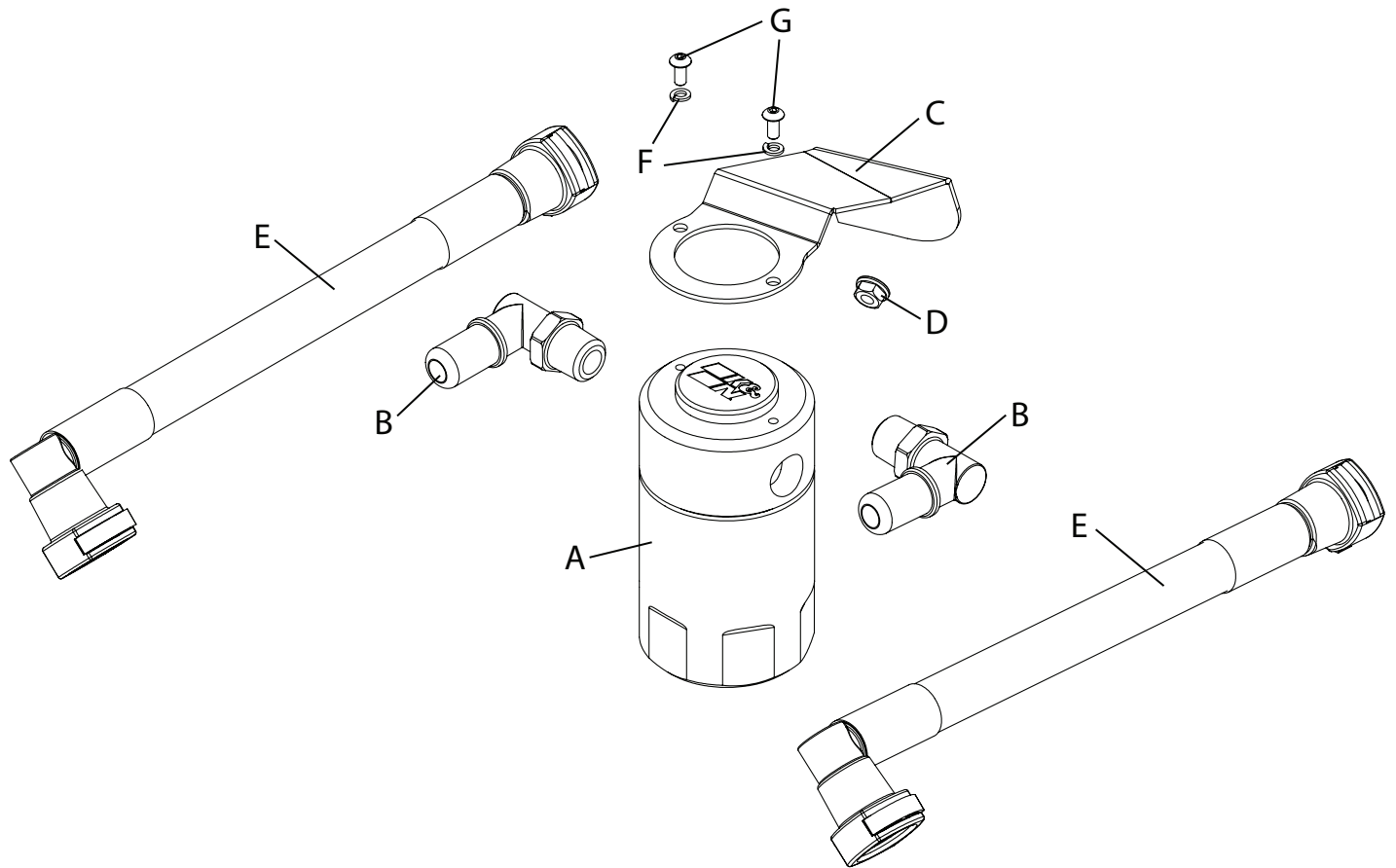

# Oil Separator INSTALLATION INSTRUCTIONS

**81-0810**  
**FORD**  
**2021-23 Bronco 2.7L**



## PARTS LIST:

	Description	Qty.	Part #
A	CATCH CAN; 2.5"OD X 4.5"H	1	85-6860
B	QUICK RELEASE; 3/8" NPT 90°	2	082634
C	BRACKET	1	010228
D	M6 SERRATED HEX NUT	1	AEM-444.460.04
E	HOSE; 1/2"ID X 9.25"L	2	084155
F	18-8 SPLIT LOCK WASHER	2	92146A618
G	BUTTON HEAD CAP SCREW	2	91255A192

## TOOLS NEEDED:

2.5mm Allen key  
Ratchet  
10mm Deep Socket  
13/16" Wrench

1. Verify you have all the parts included in the kit.

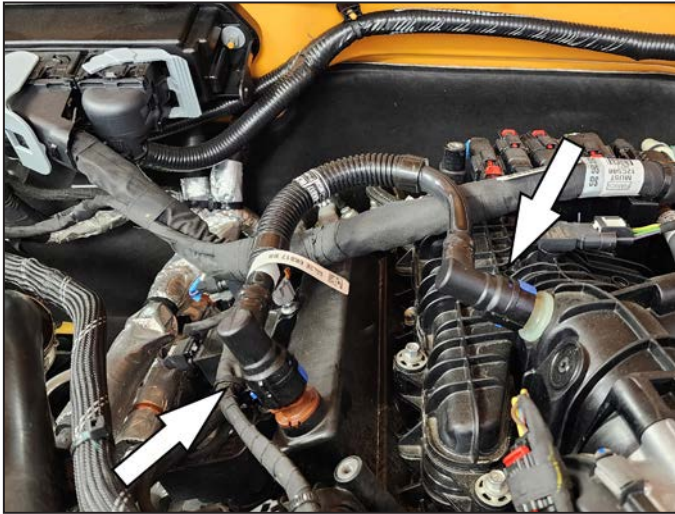

2. Remove factory PCV line by pulling tabs and removing it from the PCV valve and intake manifold



3. Assemble the quick disconnect fittings to the top of the air/oil separator as shown. It is required to use Teflon tape on the fittings to ensure a proper seal. **NOTE: DO NOT over-tighten fittings in top of oil separator.**

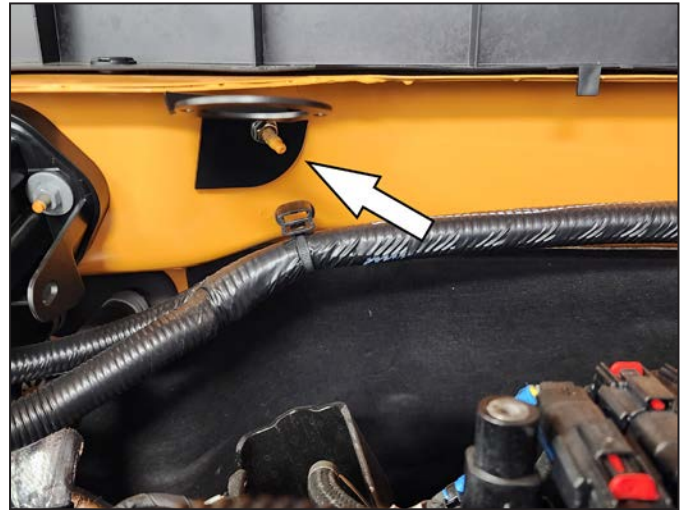

4. Remove wire harness holder on firewall and install mounting bracket using M6 nut.

5. Mount the canister to the bracket using the two button head screws and lock washers.



6. Install hoses on to oil separator as shown with K&N logo facing the front of the vehicle. Mount the hose on passenger side to valve cover PCV connection. Mount the hose on the driver side to the intake manifold. **NOTE: Lightly coat the O-Ring with oil to insert easily.**

7. Reinstall wire harness holder back on stud with bracket.

8. We recommend to check the oil separator every 10,000 miles or 12 months (sooner if vehicle is driven in harsher conditions such as towing or off-road).