

## INSTALLATION INSTRUCTIONS

**69-8624TC**  
**TOYOTA / SUBARU**  
**2022 86**  
**H4-2.4L**  
**2022 BRZ**  
**H4-2.4L**

**TOOLS NEEDED:**

- Phillips screw driver
- Pliers
- Ratchet
- Extension
- 13mm socket
- 12mm socket
- 10mm socket
- 3mm Allen wrench
- 10mm wrench.

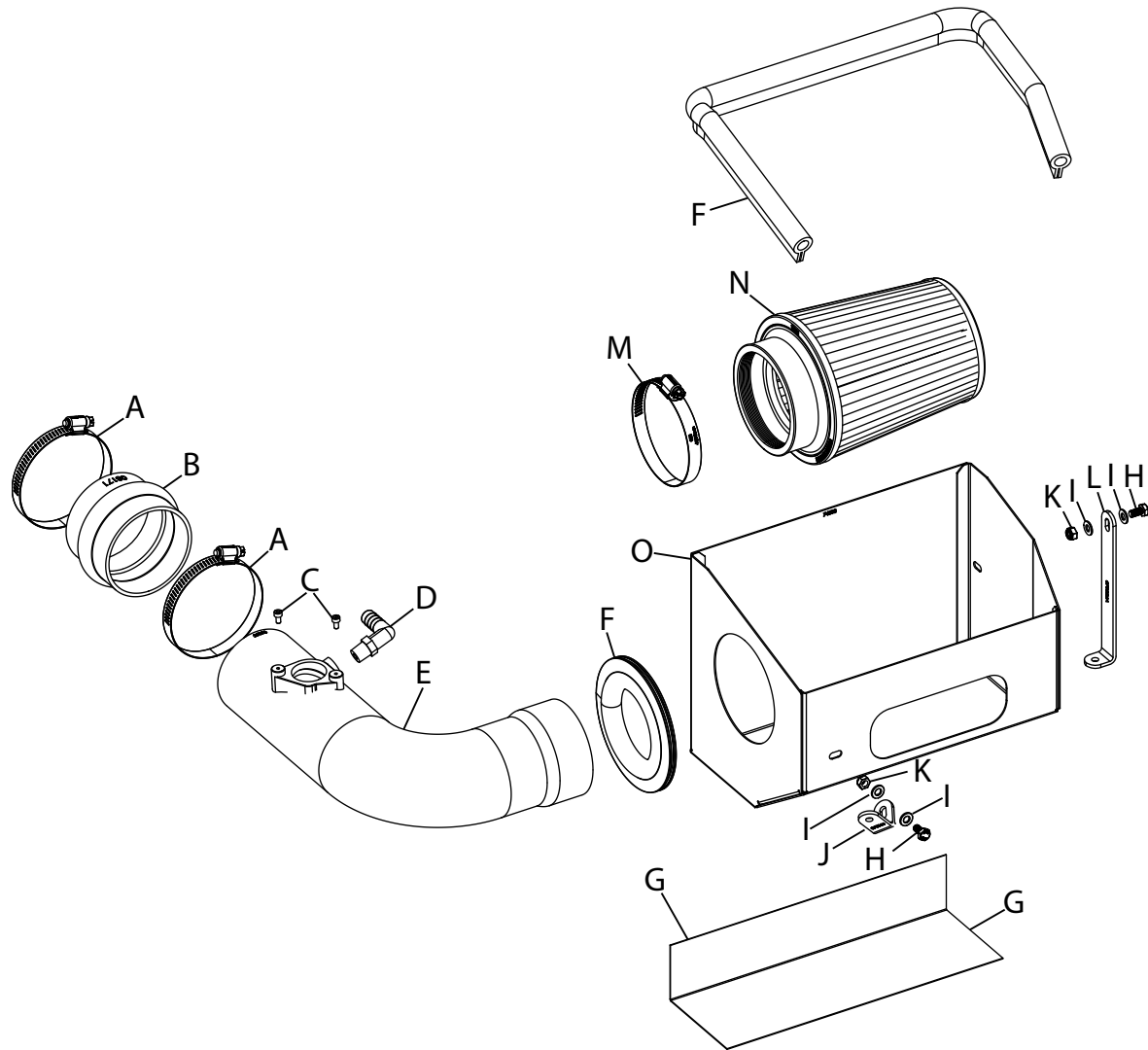

**PARTS LIST:**

Description	Qty.	Part #	Description	Qty.	Part #	Description	Qty.	Part #
A HOSE CLAMP; #52	2	08610	F EDGE TRIM; 44"L	1	102486A	K NUT; 6MM NYLOCK	2	07512
B HOSE; HUMP 3.25"ID X 2-5/8"L	1	08171	G ADHESIVE; HEAT BARRIER	2	8-165	L BRACKET; "L" SMALL	1	070026A
C BOLT; M4-.7 X 8MM, ALLEN HD	2	07733	H BOLT; M6-1 X 16MM	2	07812	M HOSE CLAMP; #60	1	08624
D VENT; 90 DEG, 1/2"HOSE	1	08110FK	I WASHER; 6MM FLAT	4	08269	N AIR FILTER	1	RU-4630XD
E INTAKE TUBE; (AL)	1	25893C	J BRACKET; "L" SML	1	070066A	O HEAT SHIELD	1	074558

**If you need any assistance please call 1-800-858-3333 to speak with a representative in our Customer Service Center before returning the product.**

**NOTE: FAILURE TO FOLLOW INSTALLATION INSTRUCTIONS AND NOT USING THE PROVIDED HARDWARE MAY DAMAGE THE INTAKE TUBE, THROTTLE BODY AND ENGINE.**

**TO START:**

1. Turn off the ignition and disconnect the negative battery cable.  
**NOTE: Disconnecting the negative battery cable erases pre-programmed electronic memories. Write down all memory settings before disconnecting the negative battery cable. Some radios will require an anti-theft code to be entered after the battery is reconnected. The anti-theft code is typically supplied with your owner's manual. In the event your vehicles anti-theft code cannot be recovered, contact an authorized dealership to obtain your vehicles anti-theft code.**



2. Disconnect the mass air sensor electrical connection and unhook the wiring harness from the air box.



3. Release the spring clamp and then disconnect the crank case vent hose from the fitting. Loosen the hose clamp securing the intake hose to the throttle body.



4. Remove the two bolts shown securing the resonator and air box to the core support. **NOTE: These bolts will be reused in a later step.**



5. Remove the remaining air box mounting bolt then lift up the air box assembly and remove it from the vehicle. **NOTE: This bolt will be reused in a later step.**



6. Install the provided heat shield mounting bracket (070026) onto the lower air box mount using the factory bolt.



7. Install the provided silicone hose (08186) onto the throttle body and secure with the provided hose clamp.



8. Install the provided heat shield insulation strips onto the bottom of the heat shield as shown. Some trimming of the insulation strips excess will be necessary.

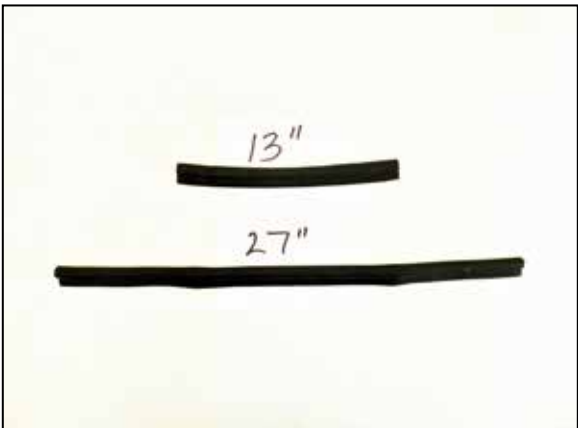

9. Cut the provided edge trim into two sections, one section is to be 27" long and the other section is to be 13" long.



10. Install the 13" long section of edge trim into the hole of the heat shield as shown and then install the 27" long section of edge trim onto the top of the heat shield as shown.



11. Install the provided "L" bracket (070066) onto the heat shield using the provided hardware.



12. Set the heat shield into position on the core support and secure with the factory air box mounting bolts and to the previously install bracket with the hardware provided.



13. Remove the mass air sensor from the factory air filter housing and then install it into K&N intake tube using the provided hardware. Install the provided 90° vent fitting into the K&N intake tube as shown. Apply the K&N decal as shown.



14. Install the tube through the heat shield. Rotate the tube down and install it into the silicone hose on the throttle body. Secure the tube with the provided hose clamp. **NOTE: The tube is a tight fit through the opening, take care so as not to damage the edge trim.**



15. Connect the crank case vent to the fitting installed into the K&N intake tube as shown. Reconnect the mass air sensor electrical connection.



16. Install the K&N air filter onto the K&N intake tube and secure with the provided hose clamp.



17. Reconnect the vehicle's negative battery cable. Double check to make sure everything is tight and properly positioned before starting the vehicle.

18. It will be necessary for all K&N® high flow intake systems to be checked periodically for realignment, clearance and tightening of all connections. Failure to follow the above instructions or proper maintenance may void warranty.

#### ROAD TESTING:

1. Start the engine with the transmission in neutral or park, and the parking brake engaged. Listen for air leaks or odd noises. For air leaks secure hoses and connections. For odd noises, find cause and repair before proceeding. This kit will function identically to the factory system except for being louder and much more responsive.
2. Test drive the vehicle. Listen for odd noises or rattles and fix as necessary.
3. If road test is fine, you can now enjoy the added power and performance from your kit.
4. K&N Engineering, Inc., requires cleaning the intake system's air filter element every 100,000 miles. When used in dusty or off-road environments, our filters will require cleaning more often. We recommend that you visually inspect your filter once every 25,000 miles to determine if the screen is still visible. When the screen is no longer visible some place on the filter element, it is time to clean it. To clean and re-oil, purchase our filter Recharger® service kit, part number 99-5050 or 99-5000 and follow the easy instructions.

**NOT LEGAL FOR SALE OR USE ON ANY POLLUTION CONTROLLED MOTOR VEHICLE IN CALIFORNIA OR STATES ADOPTING CALIFORNIA EMISSION PROCEDURES.**

See [knfilters.com](http://knfilters.com) for CARB status on each part for a specific vehicle