

## INSTALLATION INSTRUCTIONS

### 69-5300

**Hyundai**  
**2003 Tiburon GT**  
**V6-2.7L**

#### TOOLS NEEDED:

Flat blade Screw  
Driver  
Phillips Screw Driver  
Ratchet  
6" Extension  
10mm Socket  
12mm Socket  
Lug Nut Wrench

**NOTE: FAILURE TO FOLLOW INSTALLATION INSTRUCTIONS AND NOT USING THE PROVIDED HARDWARE MAY DAMAGE THE INTAKE TUBE, THROTTLE BODY AND ENGINE.**

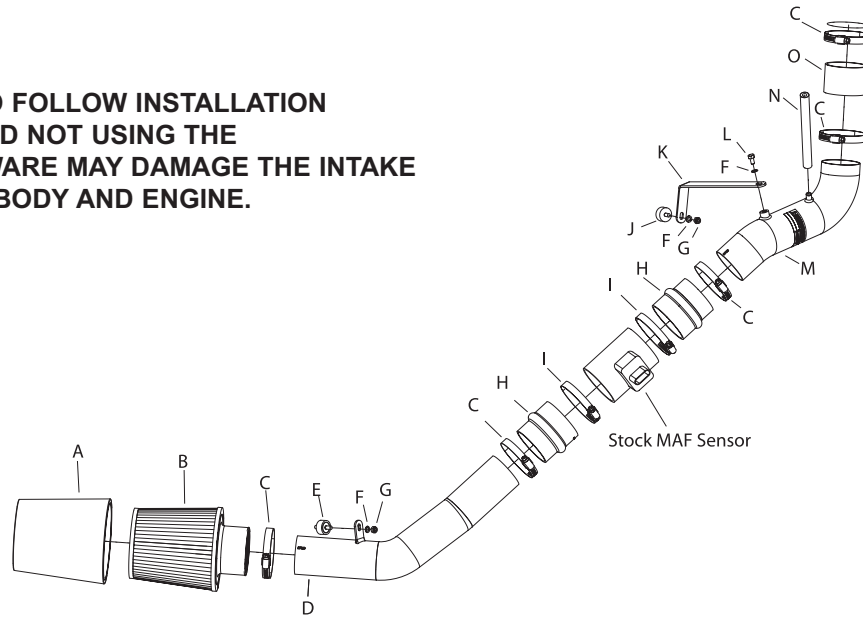

#### Parts List

Description	Qty.	P/N	Description	Qty.	P/N
A DRYCHARGER; BLACK	1	971000DK	J VIBRATION MOUNT, MF	1	070228
B FILTERCHARGER	1	KRU4870E	K BRACKET; "L" 69-5300	1	010072
C HOSE CLAMP #44	5	08560	L BOLT; M6-1.00X12MM, SS	1	07727
D THROTTLE BODY TUBE	1	27322	M COLD-AIR EXTENSION TUBE	1	27323TS
E VIBRATION MOUNT M/M	1	07027	N HOSE; 8MM X 6-1/2"L, BLACK SILICONE	1	084020
F WASHER; 6MM WAVE, SS	3	08277	O HOSE; 2-3/4"ID X 2"L, STRT, BLACK	1	08440
G NUT; 6MM NYLOCK; SS	2	07512			
H HOSE; 2-3/4"ID TO 3"ID, STEP HUMP, BLK	2	084044			
I HOSE CLAMP #48	2	08601			

#### TO START:



1. Turn the vehicles ignition off and remove the negative battery terminal cover, then, disconnect the negative battery cable as shown.



2. Remove the three engine cover panels using a flat blade screwdriver.

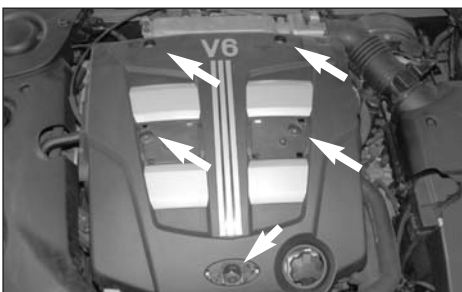

3. Remove the engine cover, which is secured by 5 bolts as shown.



4. Remove the two plastic rivets and one bolt, then, remove the air cleaner cover as shown.



5. Remove the wire clip, then, disconnect the mass air sensor electrical connection as shown.

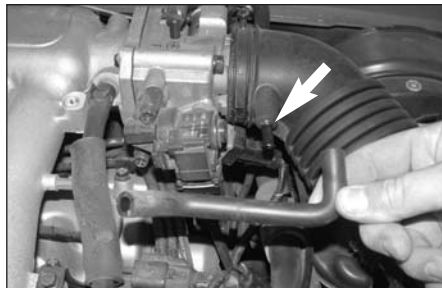

6. Disconnect the crank case vent hose and remove from the engine as shown.



7. Loosen the hose clamps at the throttle body and at the mass air sensor, then, remove the stock intake tube as shown.



8. Unclip the air cleaner cover and remove as shown.



9. Remove the lower air cleaner assembly, which is secured by three bolts.



10. Remove the battery cover, which is secured by 4 plastic rivets and one bolt as shown.



11. Raise the vehicle up and support it with a jack stand, then, remove the front tire as shown.



12. Remove five plastic rivets and one bolt, then, pull in the inner fender valance down as shown.



13. Remove the bolt that secures the air inlet duct to the battery tray as shown.

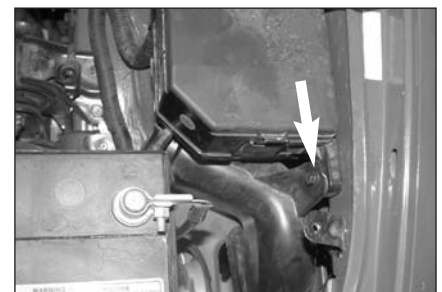

14. Remove the bolt that secures the air cleaner duct to the inner fender as shown.



15. From underneath the vehicle remove the two bolts and one clip, then, remove the resonator from the vehicle as shown.



16. Remove the fuse box bolts, lift upward, then, remove the air cleaner duct as shown.

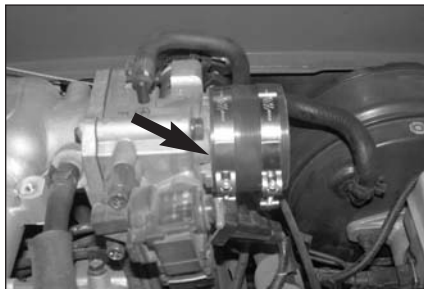

17. Install the silicone hose and hose clamps onto the throttle body and secure as shown.



18. Install the provided rubber mounted stud into the original air cleaner mounting hole as shown.



19. Install the provided bracket onto the rubber mounted stud and secure using the provided hardware, but do not tighten completely at this time.



20. Install the provided hose onto the K&N throttle body tube as shown. **NOTE:** Before installing the hose, inspect the inside of the tube for any debris, then clean the inside out with water and a towel. Inspect the tube one more time before proceeding to the next step.

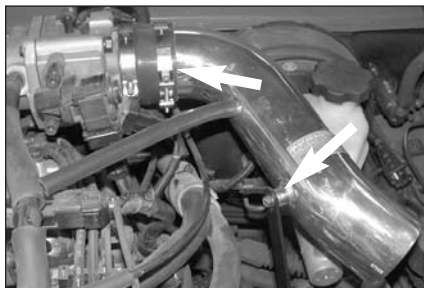

21. Slide the intake tube into the silicone hose on the throttle body, then line up the threaded boss with the bracket from step 19 and secure with the provided hardware, but do not tighten at this time.

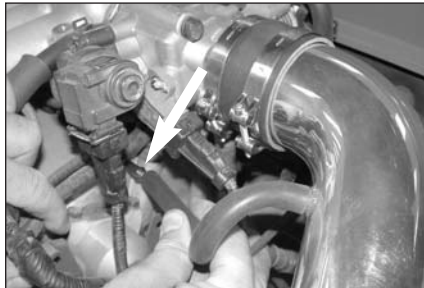

22. Connect the crank case vent hose to the crank case vent as shown.



23. Remove the mass air sensor from the air cleaner cover as shown.



24. Install the two silicone hump hoses and hose clamps onto the mass air sensor and secure as shown.



25. Slide the mass air sensor assembly onto the throttle body tube and snug the hose clamp but do not tighten completely at this time.  
**NOTE:** The mass air sensor should be installed so that airflow arrow on the side of the mass air sensor is pointed towards the throttle body.



26. From underneath the vehicle, install the rubber mounted stud onto the existing stud located on the bottom of the inner fender rail as shown.



27. Slide the cold air tube through the fender from underneath the vehicle and into the silicone hump hose as shown.



28. Line up the cold air tube bracket with the rubber mounted stud from step 26 and secure with the provided hardware as shown.



29. Install the K&N Drycharger onto the K&N Filtercharger as shown.



30. Install the Filtercharger from under the vehicle and secure with the provided hose clamp as shown.



31. Secure the fuse box using the original bolts.

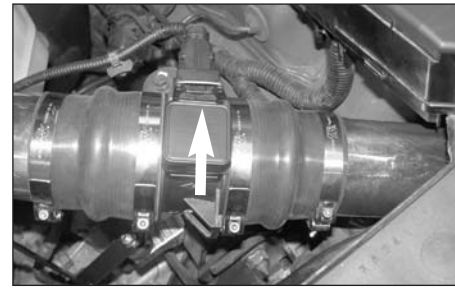

32. Reconnect the mass air sensor and secure with the wire clip as shown.

33. Reverse the removal process and secure the inner fender valance.

34. Reinstall the front tire and torque to factory specs.

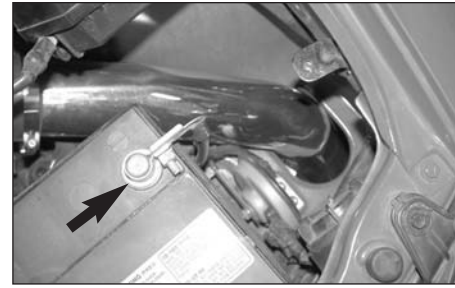

35. Reconnect the negative battery cable and double check that everything is tight and properly positioned before starting the vehicle.

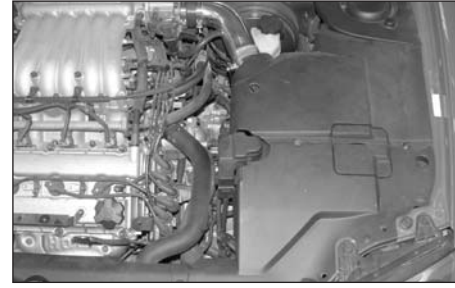

36. Reinstall both plastic battery covers as shown.



37. Reinstall the engine cover as shown.

38. The C.A.R.B. exemption sticker, (attached), must be visible under the hood, so that an emissions inspector can see it when the vehicle is required to be tested for emissions. California requires testing every two years, other states may vary.

39. It will be necessary for all Typhoons to be checked periodically for realignment, clearance and tightening of all connections. Failure to follow the above instructions or proper maintenance may void warranty.

#### ROAD TESTING:

1. Start the engine with the transmission in neutral or park, and the parking brake engaged. Listen for air leaks or odd noises. For air leaks secure hoses and connections. For odd noises, find cause and repair before proceeding. This kit will function identically to the factory system except for being louder and much more responsive.
2. Test drive the vehicle. Listen for odd noises or rattles and fix as necessary.
3. If road test is fine, you can now enjoy the added power and performance from your kit.
4. K&N suggests checking the Filtercharger element periodically for excessive dirt build-up. When the element becomes covered in dirt (or once a year), service it according to the instructions on the Recharger service kit, part number 99-5000 or 99-5050.