

TYPHOON INTAKE SYSTEMS



INSTALLATION INSTRUCTIONS

69-4900

Opel Astra G

1998-2000

1.8L L4 16v 115 bhp

Tools Needed:

10 mm spanner
Torx 30 screwdriver
Side cutting pliers
Flat blade screwdriver
Ratchet and extension
Torx socket E14

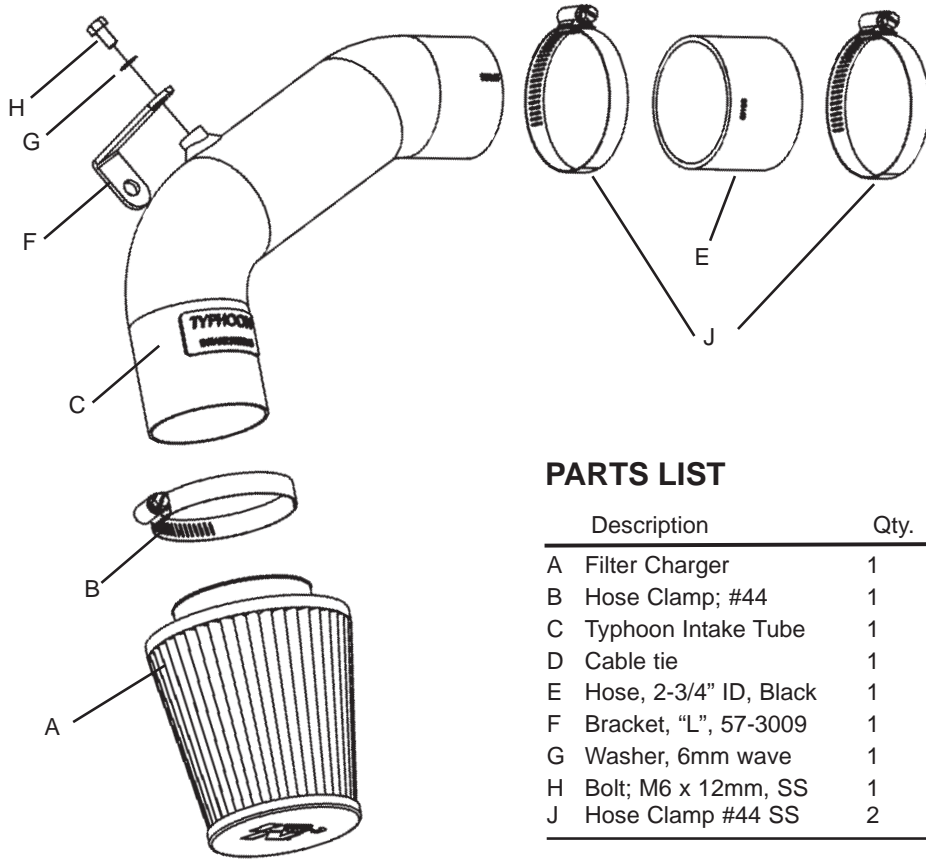
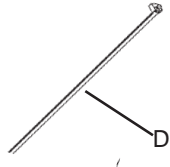

PARTS LIST

Description	Qty.	P/N
A Filter Charger	1	RC-9350
B Hose Clamp; #44	1	08577
C Typhoon Intake Tube	1	27388
D Cable tie	1	21590
E Hose, 2-3/4" ID, Black	1	08440
F Bracket, "L", 57-3009	1	070602
G Washer, 6mm wave	1	08277
H Bolt; M6 x 12mm, SS	1	07277
J Hose Clamp #44 SS	2	08560

TO START:

1. Turn the ignition OFF and disconnect the vehicle's negative battery terminal.

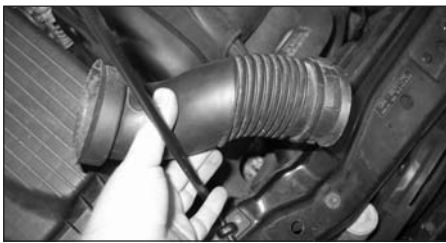

2. Remove the air box feed pipe from between the air box and intake snorkel as shown.



3. Unclip and remove the intake hose from between the air box and the mass air sensor (MAS).



4. Unclip the electric fuel valve from the air box as shown.



5. Remove the screw that secures the air box to the vehicle as shown.



6. Remove the complete air box from the vehicle as shown.

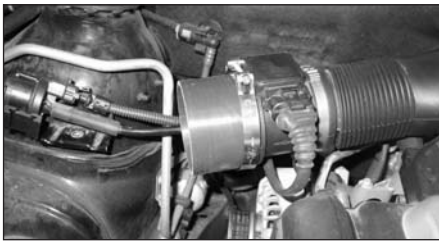

7. Fit the silicone sleeve onto the MAS using the #44 hose clamp supplied.



8. Remove the bolt of the engine support bracket as shown.



9. Mount the "L" bracket onto the engine support bracket. (Do not fully tighten at this moment.)



10. Fit the tube into the silicone sleeve using the #44 hose clamp. (Do not fully tighten at this moment.) **NOTE:** Before installing, clean the inside of out with water and a towel!



11. Fit the tube onto the "L" bracket using the M6 bolt and waved washer supplied. (Do not fully tighten at this moment.)



12. Align the tube and gently remove the tube. (in this way you have the bracket in the right position.)



13. Firmly tighten the bolt that secures the "L" bracket to the engine support bracket.



14. Refit the tube into the sleeve and firmly tighten the #44 hose clamp.



15. Fit the tube onto the "L" bracket and firmly tighten the M6 bolt.



16. Mount the filter onto the tube using the #44 hose clamp supplied.

Continued on reverse side!



17. Fit the electric fuel valve onto the air conditioning pipe using the cable tie supplied.



18. Double check to make sure everything is tight and properly positioned before starting the vehicle.



19. It will be necessary for all Typhoons to be checked periodically for realignment, clearance and tightening of all connections. Failure to follow the above instructions or proper maintenance may void warranty.

ROAD TESTING:

1. Start the engine with the transmission in neutral or park, and the parking brake engaged. Listen for air leaks or odd noises. For air leaks secure hoses and connections. For odd noises, find cause and repair before proceeding. This kit will function identically to the factory system except for being louder and much more responsive.

2. Test drive the vehicle. Listen for odd noises or rattles and fix as necessary.

3. If road test is fine, you can now enjoy the added power and performance from your kit.

4. K&N suggests checking the Filtercharger element periodically for excessive dirt build-up. When the element becomes covered in dirt (or once a year), service it according to the instructions on the Recharger service kit available from your K&N dealer, part number 99-5000 or 99-5050