



# AIRCHARGER®

## HIGH-FLOW INTAKE KITS

NOT LEGAL FOR SALE OR USE ON ANY POLLUTION CONTROLLED MOTOR VEHICLE IN CALIFORNIA OR STATES ADOPTING CALIFORNIA EMISSION PROCEDURES.

See knfilters.com for CARB status on each part for a specific vehicle

### INSTALLATION INSTRUCTIONS

**63-3104**

**CHEVROLET / GMC**

**2017-18 Colorado / Canyon**

**V6-3.6L**

**TOOLS NEEDED:**

- ratchet
- extension
- 10mm socket
- flat blade screw driver
- phillips screw driver

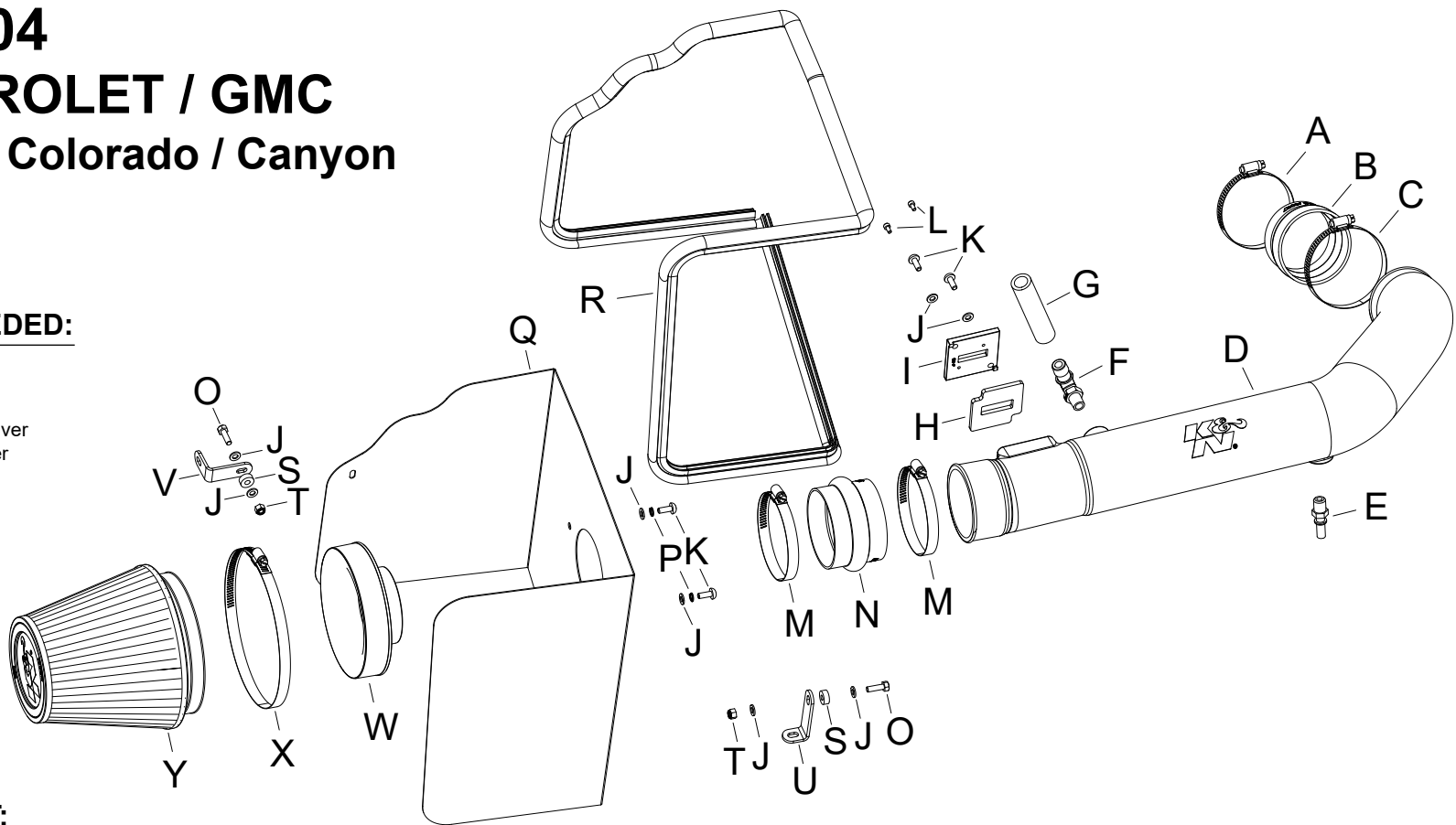

**PARTS LIST:**

| Description                    | Qty. | Part # | Description                    | Qty. | Part # | Description                  | Qty. | Part #    |
|--------------------------------|------|--------|--------------------------------|------|--------|------------------------------|------|-----------|
| A HOSE CLAMP #48               | 1    | 08601  | I ADAPTOR; 57-2556, NYLON      | 1    | 21515  | Q HEAT SHIELD                | 1    | 073254    |
| B HOSE; 3.25"ID TO 3"ID X 2"L  | 1    | 08186  | J WASHER; 6MM FLAT, SS         | 8    | 08269  | R EDGE TRIM (80")            | 1    | 102461    |
| C HOSE CLAMP #52               | 1    | 08610  | K BOLT; M6 X 1.00 X 16MM, SS   | 4    | 07730  | S SPACER: .625" OD X .250"ID | 2    | 06555     |
| D INTAKE TUBE                  | 1    | 087363 | L BOLT; M4 - 0.07 8MM, A/H CAP | 2    | 07733  | T NUT; 6MM NYLOCK, HEXHEAD   | 2    | 07512     |
| E VENT; STRT 1/4" NPT QUICK    | 1    | 08938  | M HOSE CLAMP #56               | 2    | 08620  | U BRACKET; 63-1025, SMALL    | 1    | 070015    |
| F FITTING; VENT 1/4NPT, 90DEG  | 1    | 08525  | N HOSE; HUMP 3.5"ID X 2.5"L    | 1    | 08699  | V BRACKET; "L", TB/PC        | 1    | 07805     |
| G HOSE; 5/8" ID X4"L           | 1    | 08244  | O BOLT; M6 X 1.00" X 20MM HEX  | 2    | 07795  | W ADAPTER; UNIVERSAL, 6"     | 1    | 21512-1   |
| H GASKET; 57-2556, 3/16" PORON | 1    | 09069  | P WASHER, M6 SPLIT LOCK ZINC   | 2    | 1-3025 | X HOSE CLAMP; #104           | 1    | 08697     |
|                                |      |        |                                |      |        | Y FILTER CHARGER             | 1    | RF-1042XD |

**If you need any assistance please call 1-800-858-3333 to speak with a representative in our Customer Service Center before returning the product.**

**NOTE: FAILURE TO FOLLOW INSTALLATION INSTRUCTIONS AND NOT USING THE PROVIDED HARDWARE MAY DAMAGE THE INTAKE TUBE, THROTTLE BODY AND ENGINE.**

**TO START:**

1. Turn off the ignition and disconnect the negative battery cable.  
**NOTE: Disconnecting the negative battery cable erases pre-programmed electronic memories. Write down all memory settings before disconnecting the negative battery cable. Some radios will require an anti-theft code to be entered after the battery is reconnected. The anti-theft code is typically supplied with your owner's manual. In the event your vehicles anti-theft code cannot be recovered, contact an authorized dealership to obtain your vehicles anti-theft code.**



2. Loosen the hose clamp that secures the intake hose to the air filter housing. Using a screwdriver, unlock the small clamp that secures the vent line to the connector and then disconnect the vent line. Remove the bolt securing the intake plenum to the engine.



3. Remove the oil fill cap and loosen the hose clamp securing the intake hose to the throttle body. Remove the bolt securing the intake plenum to the engine.



4. Remove the front center bolt securing the intake plenum to the engine and remove the intake plenum from the vehicle.  
**NOTE: K&N Engineering, Inc., recommends that customers do not discard factory air intake.**



5. Release the red locking tab and then disconnect the mass air sensor electrical connection and unhook the harness from the air filter housing.



6. Remove the two nuts securing the air filter housing to the inner fender and then remove the housing from the vehicle.  
**NOTE: One of the nuts will be reused in a later step.**





7. Install the filter adapter into the K&N® heat shield and secure with the provided hardware.



8. Install the edge trim onto the heat shield as shown.

**NOTE: Some trimming of the edge trim will be necessary.**



9. Install the provided heat shield mounting bracket (07805) onto the heat shield using the provided hardware and spacer.



10. Install the provided heat shield mounting bracket (070015) onto the heat shield using the provided hardware and spacer.



11. Remove the nut that secures the coolant reservoir to the inner fender.

**NOTE: This nut will be reused in the next step.**



12. Install the heat shield assembly into the vehicle and secure with the factory coolant reservoir nut and air box mounting nut.



13. Remove the mass air sensor from the factory air filter housing and install the sensor and provided gasket into the K&N® mass air sensor adapter using the provided hardware.

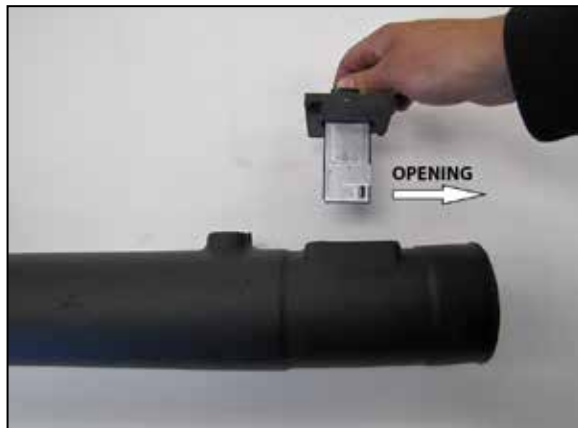

14. Install the mass air sensor assembly into the K&N® intake tube as shown, secure the sensor with the provided hardware.

**NOTE: Be sure the opening in the sensor is pointed towards the inlet end of the tube.**



15. Install the provided coupler (08186) onto the throttle body and secure with the provided hose clamp.



16. Install the 90° vent fitting into the K&N® intake tube as shown.

**NOTE: Plastic NPT fittings are easy to cross thread. Install the vent fitting “hand” tight, then turn it two complete turns with a wrench.**



17. Install the quick connect fitting into the K&N® intake tube as shown.

**NOTE: Plastic NPT fittings are easy to cross thread. Install the vent fitting “hand” tight, then turn it two complete turns with a wrench.**



18. Install the provided hump coupler (08699) onto the K&N® intake tube, then install the intake tube assembly into the coupler at the throttle body and align with the filter adapter. Slide the hump coupler onto the filter adapter, adjust the tube for best fit and secure with the provided hose clamps.



19. Rotate the crank case vent line and fitting so it aligns with the quick connect fitting and then connect.



20. Using the provided vent hose, connect the factory vent to the 90° fitting installed into the K&N® intake tube. Reconnect the mass air sensor electrical connection.



21. Install the K&N® air filter onto the filter adapter and secure with the provided hose clamp.

**NOTE: Drycharger® air filter wrap; part # RF-1042DK is available to purchase separately. To learn more about Drycharger® filter wraps or look up color availability please visit <http://www.knfilters.com>®.**



22. Reconnect the vehicle's negative battery cable. Double check to make sure everything is tight and properly positioned before starting the vehicle.

23. It will be necessary for all K&N® high flow intake systems to be checked periodically for realignment, clearance and tightening of all connections. Failure to follow the above instructions or proper maintenance may void warranty.

#### ROAD TESTING:

1. Start the engine with the transmission in neutral or park, and the parking brake engaged. Listen for air leaks or odd noises. For air leaks secure hoses and connections. For odd noises, find cause and repair before proceeding. This kit will function identically to the factory system except for being louder and much more responsive.

2. Test drive the vehicle. Listen for odd noises or rattles and fix as necessary.

3. If road test is fine, you can now enjoy the added power and performance from your kit.

4. K&N Engineering, Inc., requires cleaning the intake system's air filter element every 100,000 miles. When used in dusty or off-road environments, our filters will require cleaning more often. We recommend that you visually inspect your filter once every 25,000 miles to determine if the screen is still visible. When the screen is no longer visible some place on the filter element, it is time to clean it. To clean and re-oil, purchase our filter Recharger® service kit, part number 99-5050 or 99-5000 and follow the easy instructions.

**NOT LEGAL FOR SALE OR USE ON ANY POLLUTION CONTROLLED MOTOR VEHICLE IN CALIFORNIA OR STATES ADOPTING CALIFORNIA EMISSION PROCEDURES.**

See [knfilters.com](http://knfilters.com) for CARB status on each part for a specific vehicle