



Equipped with AEM® Dryflow™ Filter
No Oil Required!

INSTALLATION INSTRUCTIONS

PART NUMBER: 21-695

2010 MAZDA 3 L4-2.5L Manual Trans. SEE * NOTE

* NOTE: Legal in California only for racing vehicles which may never be used upon a highway

PARTS LIST

Description	Qty.	Part Number
A	1	21-202DOSK
B	1	2-1442
C	1	2-1443
D	1	5-1048
E	1	5-275
F	1	1228598
G	1	1-127
H	2	1-2023
I	1	559999
J	1	444.460.04
K	3	9444
L	2	9448

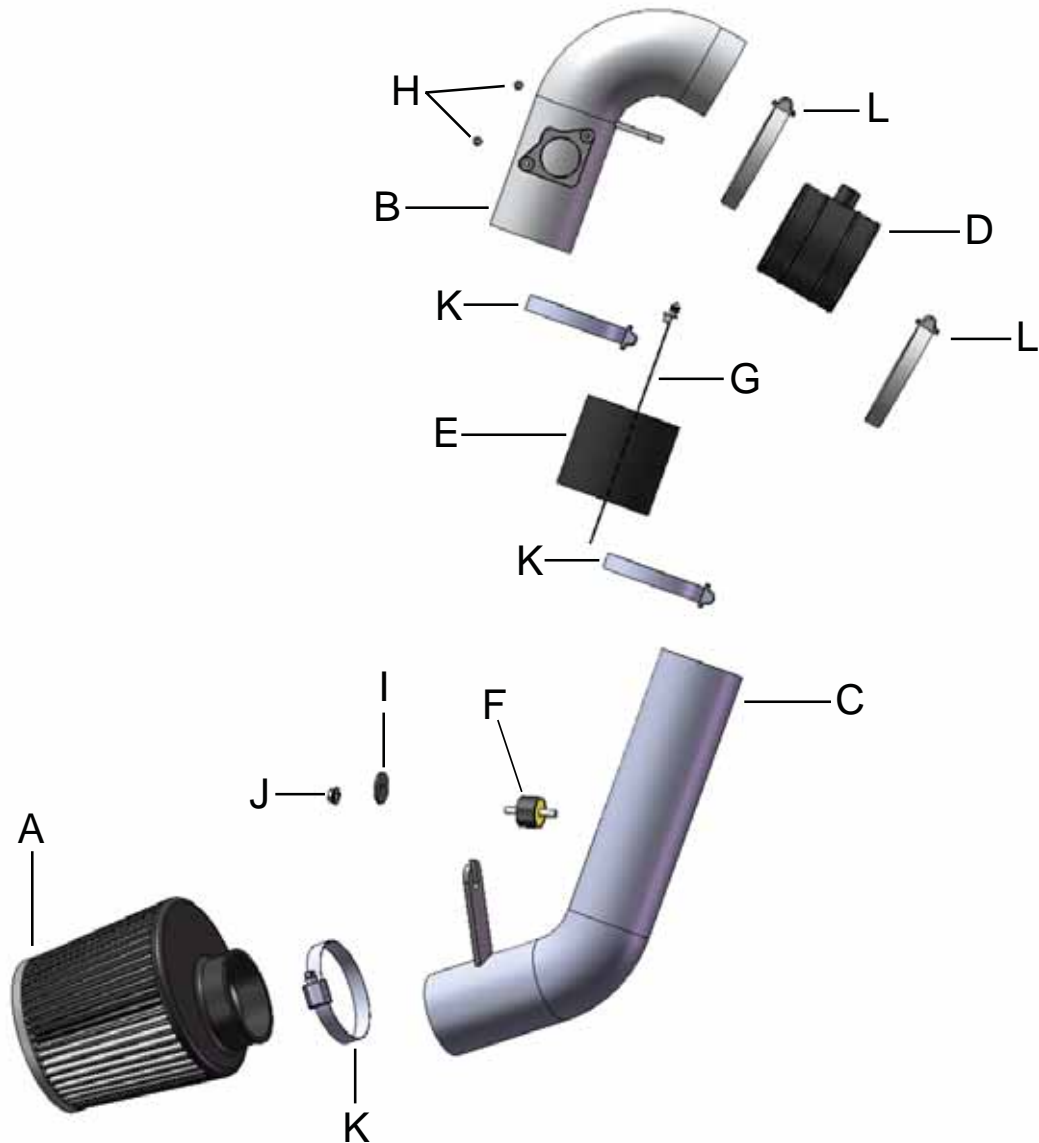

Read and understand these instructions **BEFORE** attempting to install this product. Failure to follow installation instructions and not using the provided hardware may damage the intake tube, throttle body and engine.

The AEM® intake system is a performance product that can be used safely during mild weather conditions. During harsh and inclement weather conditions, you must return your vehicle to stock OEM air box and intake tract configuration. Failure to follow these instructions will void your warranty.

1. Preparing Vehicle

- a. Make sure vehicle is parked on level surface.
- b. Set parking brake.
- c. If engine has run in the past two hours, let it cool down.
- d. Disconnect negative battery terminal.
- e. Raise the front of the vehicle with a jack. Refer to your owner's manual for proper jack and jack stand placement to properly support vehicle. Support your vehicle using properly rated jack stands before wheel removal or while working under the vehicle.
NEVER WORK UNDER A VEHICLE WITHOUT USING JACK STANDS.
- f. Do not discard stock components after removal of the factory system.

2. Removal of stock system



a. Remove front driver side wheel from the vehicle.

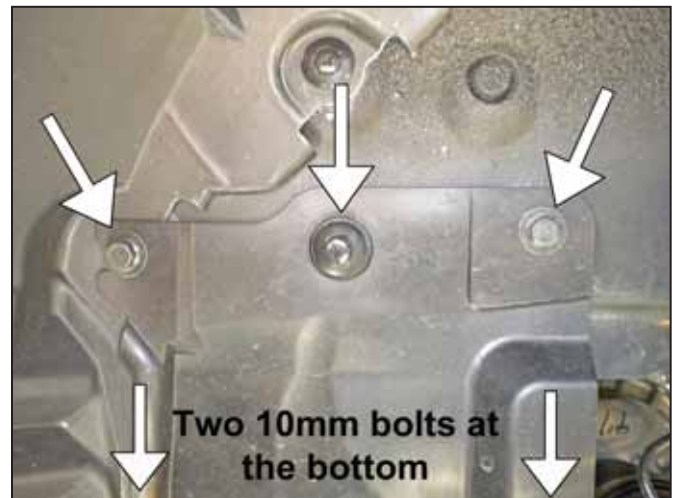

b. Remove the plastic cover, it is located to the left of the strut assembly. Begin by removing the plastic clip in the center of the two 10mm bolts at the top. Remove all four 10mm bolts (two at the top and two at the bottom) in order to remove the cover.



c. Undo the plastic clip at the bottom.

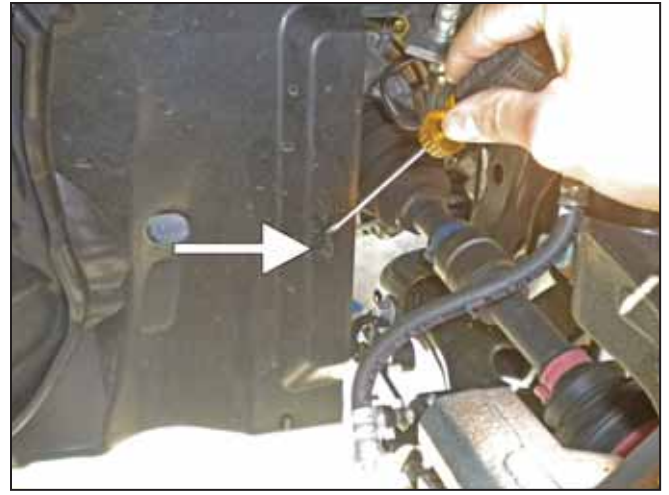

d. Undo the harness clip attached to the back side of the plastic cover.



e. Remove the plastic wheel liner. This liner is held in by 16 plastic clips as shown. To remove plastic clips use a Phillips end screw driver to remove the plastic screw in the center, then pull out the clip. A pick or flat blade screw driver can be used for popping out the two clips used in the bottom corner toward the rear of the wheel well.



f. Remove the three 8mm bolts/screws along the outer edge of the front portion of the wheel liner on the driver side.



g. Pull out the PCV hard line from the nipple located just in front of the throttle body.



h. Loosen 10mm hose clamp fastener just enough in order to remove the rubber boot over the throttle body.



i. Remove the Mass Air Flow sensor harness by pressing down on the tab and pulling it off.



j. Undo the grey plastic clip to the harness.



k. Remove the 10mm bolt attaching the air cleaner box to the core support.



l. Undo the 2 metal retaining clips holding the air box lid.



m. Remove the air box lid.

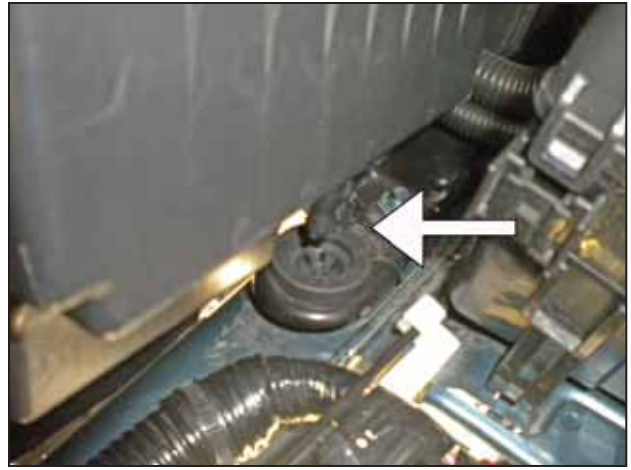

n. Remove the bottom portion of the air box. Pull up on the air box until the studs pop out of the rubber grommets.



o. Remove the plastic snorkel from the air box .

3. Installation of AEM® intake system.

a. When installing the intake system, do not completely tighten the hose clamps or mounting hardware until instructed to do so.



b. Install the coupler with the nipple onto the throttle body using the supplied size 48 hose clamps.
NOTE: The part number side of the coupler connects to the throttle body.



c. Remove the MAF sensor from the stock air box assembly.



d. Install the MAF sensor into the upper intake pipe using the supplied bolts.



e. Install the upper intake pipe onto the coupler installed earlier in step 3b.



f. Install the threaded soft mount into the location shown.



g. Use the 2.75"x3" coupler to attach the lower pipe to the upper pipe, using the supplied size 44 hose clamps. Fasten the bracket to the threaded soft mount with the supplied nut and bolt.



h. Attach the AEM® air filter onto the lower intake pipe with a size 44 hose clamp.



i. Secure the coolant hose to the bracket on the upper intake pipe with the supplied tree mount zip tie.



j. Upper intake pipe bracket secured to the coolant hose.



AEM® intake system installed

4. Reassemble Vehicle

a. **Fender liner, splashguard and plastic cover:** Install the fender liner, lower splash guard and any hardware that was removed in steps 2b. through 2f.

NOTE: Failure to install the fender liner will result in diminished performance and increase the potential for engine damage due to water ingestion in rainy conditions.

- b. **Wheel:** Install the driver side wheel using the factory torque specification (see owner's manual).
- c. Position the inlet pipes for the best fitment. Be sure that the pipes or any other components do not contact any part of the vehicle. Tighten the rubber mount, all bolts, and hose clamps.
- d. Check for proper hood clearance. Re-adjust pipes if necessary and re-tighten them.
- e. Inspect the engine bay for any loose tools and check that all fasteners that were moved or removed are properly tightened.
- f. Reconnect negative battery terminals and start engine. Let the vehicle idle for 3 minutes. Perform a final inspection before driving the vehicle.

5. Service and Maintenance

- a. It is recommended that you service your AEM® Dryflow™ filter every 20,000 miles for optimum performance. Use AEM Dryflow cleaning kit part # 21-110.
- b. Use aluminum polish to clean your polished AEM® intake tube.
- c. Use window cleaner to clean your powder coated AEM® intake tube. **(NOTE: DO NOT USE aluminum polish on powder coated AEM intake tubes).**

For technical inquiries
e-mail us at
sales@aemintakes.com
or
call us at
800.992.3000

AEM Air Intake System Warranty Policy

AEM® warrants that its intake systems will last for the life of your vehicle. AEM will not honor this warranty due to mechanical damage (i.e. improper installation or fitment), damage from misuse, accidents or flying debris. AEM will not warrant its powder coating if the finish has been cleaned with a hydrocarbon-based solvent. The powder coating should only be cleaned with a mild soap and water solution. Proof of purchase of both the vehicle and AEM intake system is required for redemption of a warranty claim.

This warranty is limited to the repair or replacement of the AEM part. In no event shall this warranty exceed the original purchase price of the AEM part nor shall AEM be responsible for special, incidental or consequential damages or cost incurred due to the failure of this product. Warranty claims to AEM must be transportation prepaid and accompanied with dated proof of purchase. This warranty applies only to the original purchaser of product and is nontransferable. Improper use or installation, use for racing, accident, abuse, unauthorized repairs or alterations voids this warranty. AEM disclaims any liability for consequential damages due to breach of any written or implied warranty on all products manufactured by AEM. Warranty returns will only be accepted by AEM when accompanied by a valid Return Merchandise Authorization (RMA) number. Credit for defective products will be issued pending inspection. Product must be received by AEM within 30 days of the date RMA is issued.

If you have a warranty issue, please call (800) 992-3000 and our customer service department will assist you. A proof of purchase is required for all AEM warranty claims.