

# **Installation Instructions**

## **JEGS SSR-III Ready-to-Run (RTR) Pro-Series Distributors**

### **Parts Included:**

- |                                   |                                |
|-----------------------------------|--------------------------------|
| (1) SSR-III Distributor           | (1) Vacuum Advance Block-off   |
| (1) Wire Retainer                 | (1) Power Extension Cable      |
| (1) Spring and Weight Advance Kit | (1) Tachometer Extension Cable |

An important feature is the fully adjustable mechanical advance. This allows you to easily modify the distributor to achieve a variety of timing curves. Included with all SSR-III distributors are four bushings of varied size. The bushing determines the mechanical advance the distributor can achieve. Also included are six springs, with two at each level of tension. The springs control the rate at which the distributor reaches the advance.

The function of the advance curve is to match the ignition timing to the burning rate of the fuel and speed (rpm) of the engine. Any factor that changes the burning rate of the fuel or the engine speed can cause a need for an ignition timing change.

The rate or how quick the advance comes in is determined by the type of springs, which are installed on the distributor. The SSR-III Distributors are equipped with two Heavy Black springs installed. These will give you the slowest advance curve possible. The parts kit contains two additional sets of springs, which can be used to match the advance curve to your particular application. To change the springs, remove the cap and rotor and use needle-nose pliers to remove the springs. Be sure the new springs seat in the groove on the pin.

Locking out the mechanical advance is not necessary for normal operation. This is necessary for some aftermarket fuel systems. Confirm with the manufacture of the fuel management system to confirm.

### **SSR-III INSTRUCTIONS**

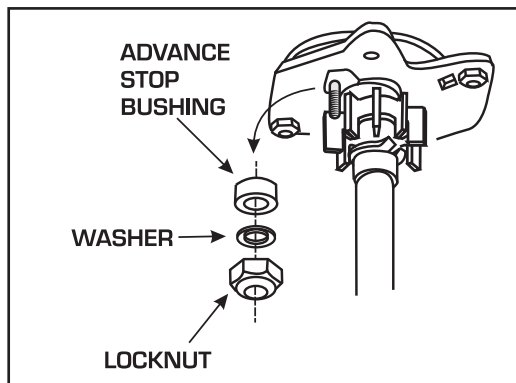

#### **CHANGING THE ADVANCE STOP BUSHINGS**

1. Remove the distributor cap and rotor.
2. Remove the locknut and washer on the bottom of the advance assembly
3. Remove the bushing and install the new one.
4. Install the washer and locknut.

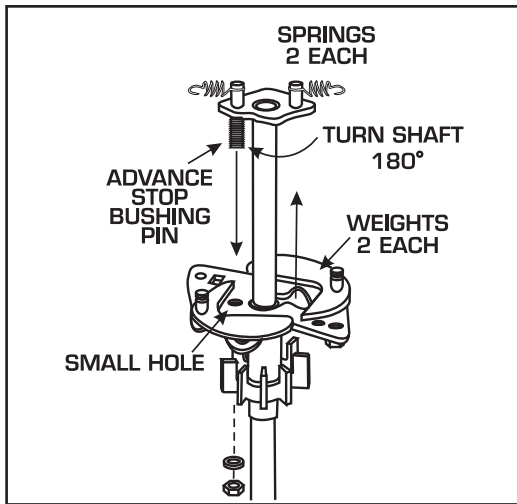

## LOCKING OUT THE CENTRIFUGAL ADVANCE

1. Remove the advance components including the springs, weights and the advance stop bushing from the advance assembly.
2. Remove the roll-pin from the drive gear and remove the gear from the shaft.
3. Slide the shaft two inches out of the housing.
4. Rotate the shaft 180° and insert the advance stop bushing pin into the small hole on the advance plate
5. Install the locknut and washer to the advance stop bushing pin. This locks the advance in place.
6. Install the drive gear and roll-pin.

## ADVANCEMENT DISTRIBUTOR CHART

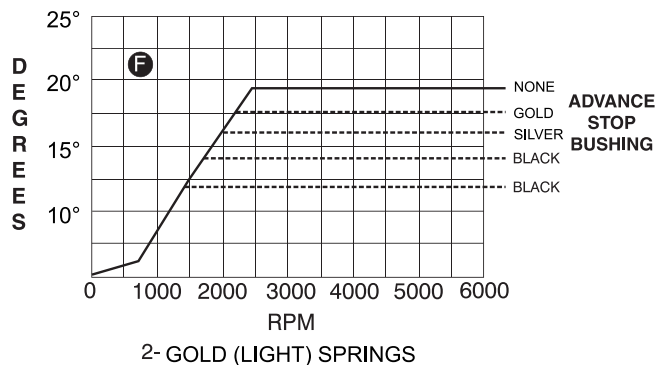
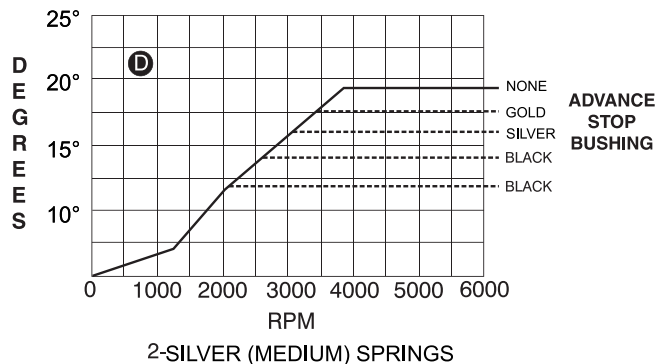
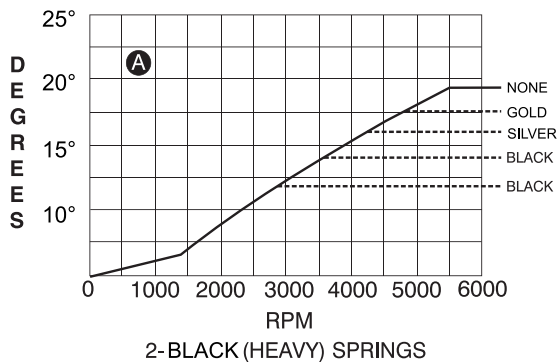

## **DISTRIBUTOR INSTALLATION :**

1. Place the engine in TDC, the rotor should be pointing to the number one cylinder. Top Dead Center is when the #1 cylinder is at the furthest point of travel before it changes to the downward stroke.
2. Disconnect the wiring from the distributor.
3. Loosen the distributor hold down clamp and slide the clamp out of the way.
4. Lift the distributor out of the engine. Note that the rotor rotates as you lift the distributor out. This is due to the helical cut gear and should be taken into consideration when installing the new distributor.
5. Install the gasket and apply a liberal amount of lubricant to the distributor gear.
6. Install the new distributor. The terminal that the rotor is pointing to will be the new number one cylinder. Removing the distributor, rotating the gear, and reinstalling can change the location of the number one terminal.
7. Install the distributor cap and sparkplug wires one at a time to ensure correct location. A wire retainer is supplied to secure the wires in place.



**1-800-345-4545 [jeps.com](http://jeps.com)**

## SSR-III READY TO RUN DISTRIBUTOR WITH E-CORE COIL

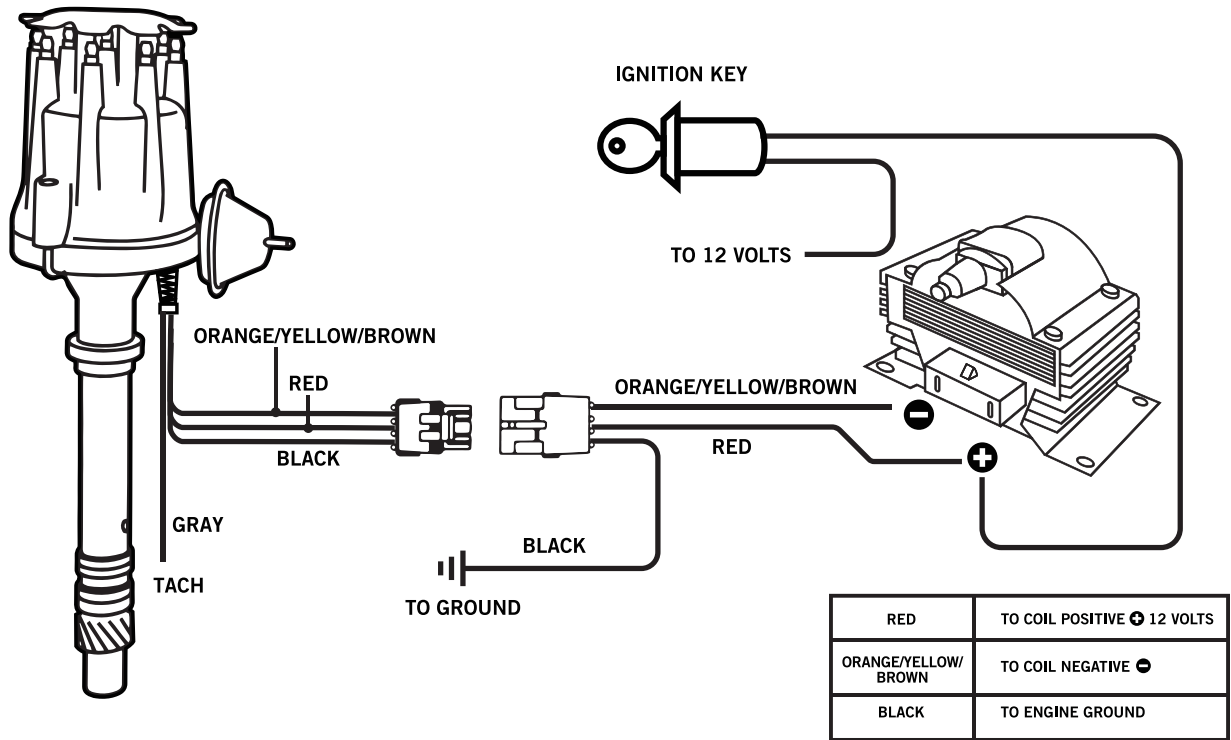

\*WARNING: This distributor is not compatible with stock points distributor coil. Must use high output coil.  
Must bypass ballast resistor if applicable.

## SSR-III READY TO RUN DISTRIBUTOR WITH CANISTER COIL

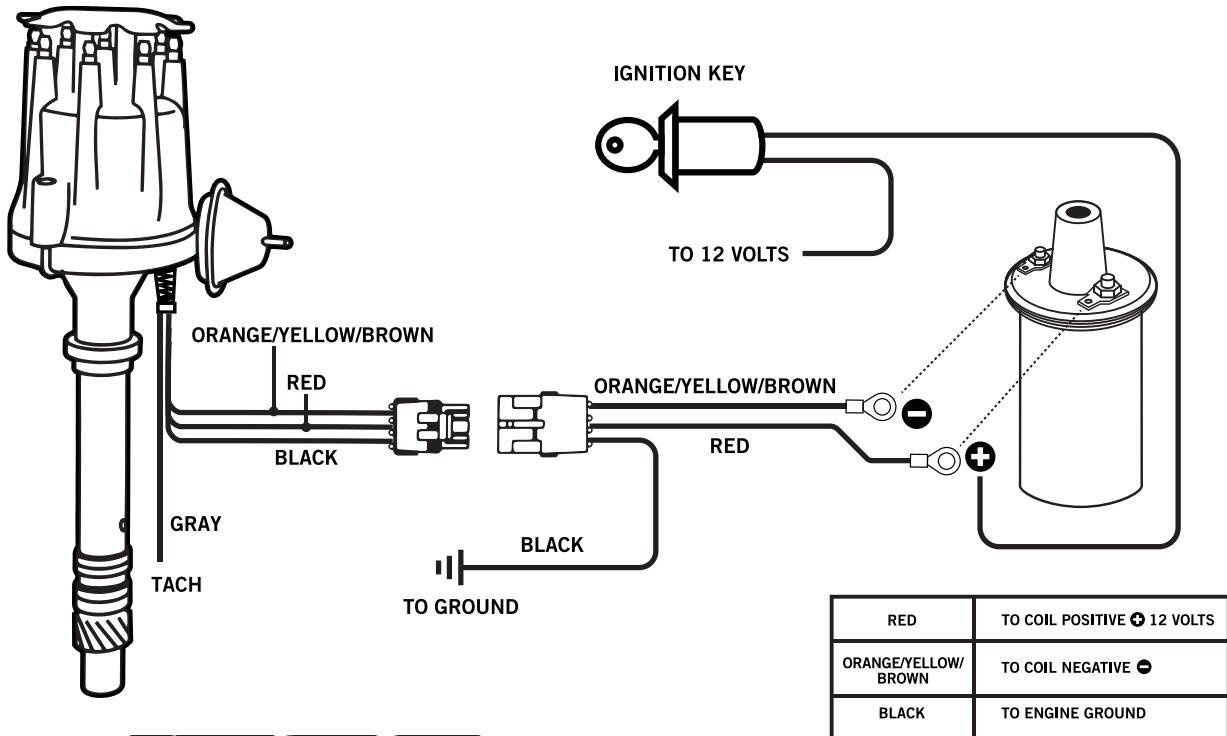

## SSR-III READY TO RUN DISTRIBUTOR WITH 6AL BOX

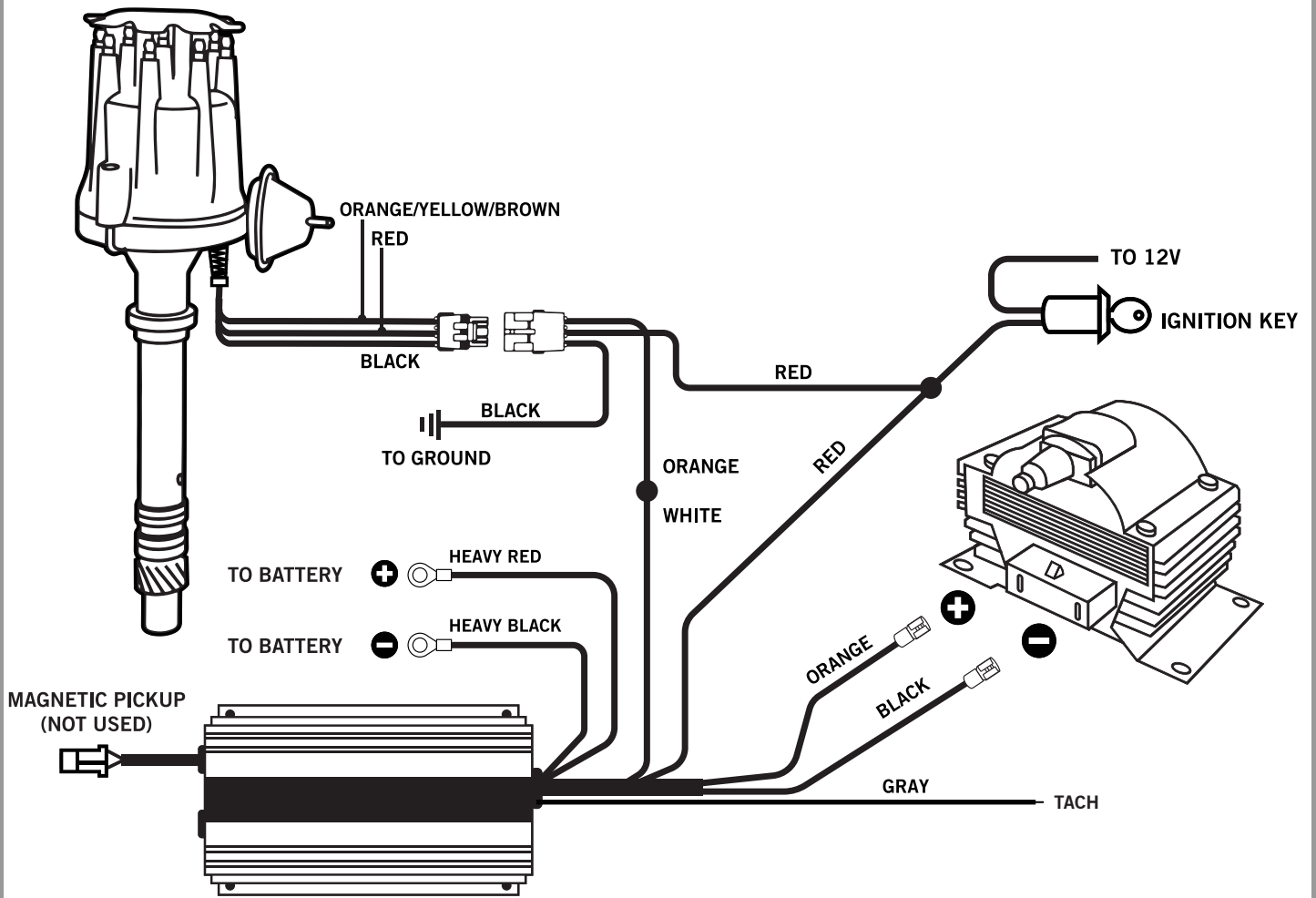

\*WARNING: This distributor is not compatible with stock points distributor coil. Must use high output coil.  
Must bypass ballast resistor if applicable.