

Inline Frame Mount Fuel Pump Kit (#50001) Installation Instructions

The FiTech Inline Fuel Pump Fuel Delivery Kit is an inexpensive solution for a fuel delivery system. This style of fuel delivery when used with a FiTech Go System EFI does require a return line to the fuel tank. All necessary hose, hose ends, and fittings are supplied.

The most critical aspect of this installation is making sure that the fuel pump and the filter between the pump and the tank are mounted as low as possible. Ideally the pump should be at least as low as the bottom of the tank. These pumps are engineered to push fuel, not draw it in from the tank. Even though the pickup from the tank may be higher than the pump, once this line is primed it will function satisfactorily. Note that mounting the pump too high will contribute to premature failure. Please read the complete instruction manual so you have a good oversight of the installation.

The Inline Fuel Pump Fuel Delivery Kit is capable of providing enough fuel for engines producing up to 600 HP when used with either the 4-injector FiTech EFI systems or also when used with the 8-injector units. Note that these systems are still suitable to be used on engines that are making as little as 200 HP.

Installation of the Fuel Delivery System

The installation of fuel related components should be done in a well ventilated area free of any possible fire hazards. Gasoline fumes are toxic and

highly inflammable.

1. Disconnect the negative (-) terminal of the battery.
2. Release the pressure in the fuel system by removing the gas cap.
3. Remove the stock fuel lines from the factory fuel pump and remove the pump from the engine. Clean off the block's mounting surface and install a fuel pump block-off plate (not supplied). Make sure you acquire a block off plate for your specific engine.
4. If a low pressure electric pump is being used you may already have a pump block-off plate and will not require a new one. Remove all of the electric pump components.

5. Disconnect the factory hard line (or hose) from the tank's sending unit assembly. Note that the factory hard lines can be completely removed if not used for the return line. If not removing or using as a return line, cap the ends of the factory hard line to avoid contamination entering the tank.

6. For proper operation of the EFI system, a return line provision must be installed onto the fuel tank sending unit. You have several options for providing a fuel return line.

Note: Some vehicles already have a return line which may be used. Other methods require welding on the tank. It is recommended that any welding be performed by a qualified professional. Here are your various options:

- A. Using the supplied rubber -06 hose:

#50001 Bill of Materials		
Item #	Qty	Description
1	40-ft	400 Series EFI Hose w/CPE Inner Liner
2	1	-06 90° Bulkhead Fitting w/Nut
3	1	-06 Bulkhead Nut
4	2	3/8" Barb Fitting for #5 Pre-Filter
5	1	60 Micron Billet Aluminum Pre-Filter
6	1	30 Micron Billet Aluminum Post-Filter
7	1	255 L/H In-Line EFI Fuel Pump
8	1	Billet Aluminum Pump Mounting Bracket
9	1	M18 x 1.5 Black Fitting - Pump Inlet
10	1	M12 x 1.5 Black Fitting - Pump Outlet
11	2	Stat-O-Seals
12	1	3/8" Barb to -06 AN Hose End
13	2	-06 AN Female to 3/8" Barb 45° Hose Ends
14	10	Stainless Steel EFI Hose Clamps
15	1	Adel Clamp to secure Filter

Plumbing Layout for External Frame Mount Inline Pump Fuel Delivery Kit #50001

Note that the FiTech EFI Throttle Body has three fuel inlet ports that can be used. Any unused port should have a plug installed.

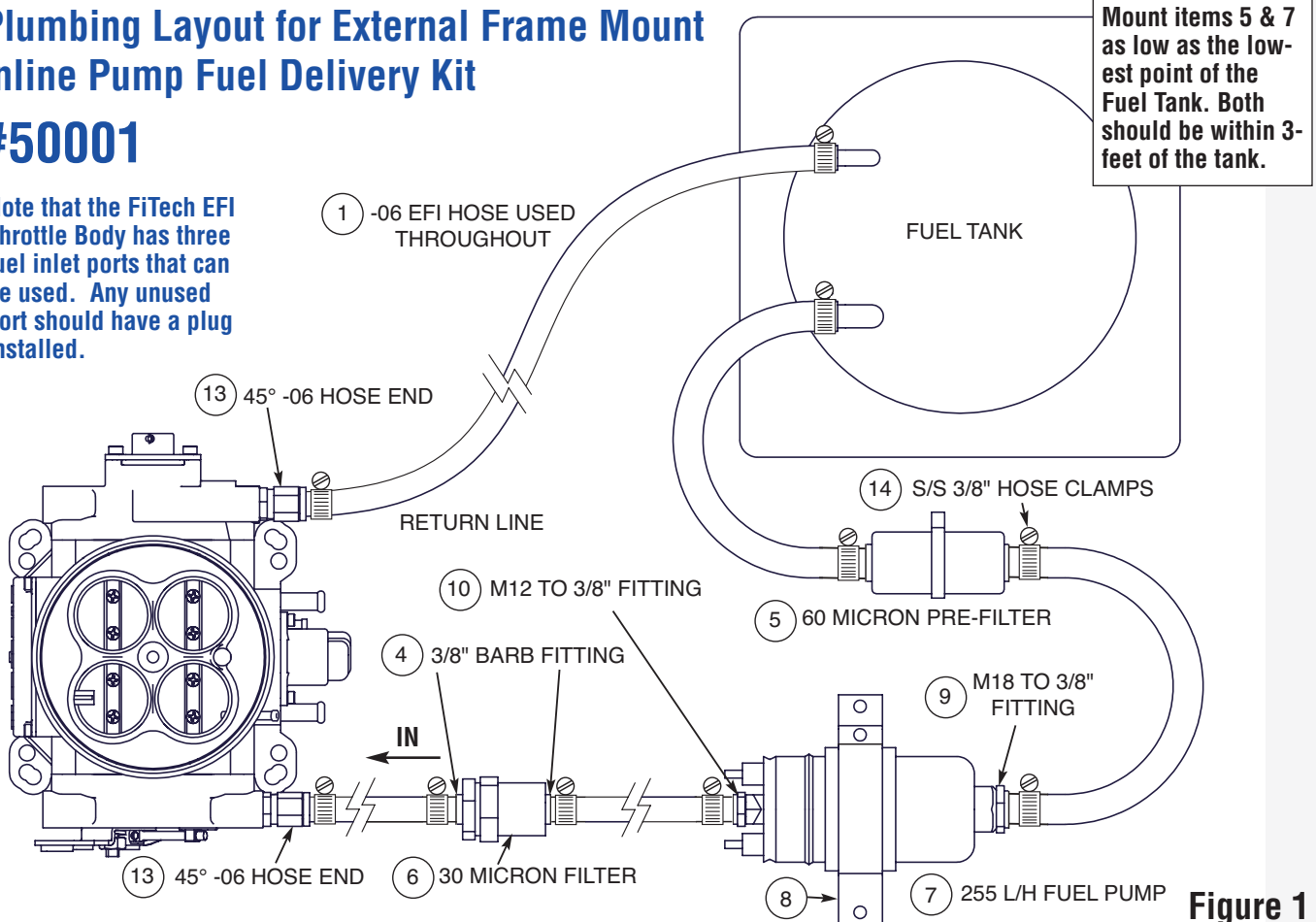

Figure 1

1. Use supplied hardware and install return line fittings as outlined in Figure 2.

2. Install a Moroso #65385 Return Kit in your filler neck. See Figure 3.

B. Use the vehicle's existing fuel hard line as the fuel return line with modification to the sending unit and pickup.

C. Use the vehicle's existing fuel return line (if equipped) as the fuel return line.

Note: Regardless of which of the above systems you use for a return line, it is important to locate the in-tank return line as far as possible from the fuel pickup line. This will avoid drawing aerated return fuel into the inlet line fuel pickup which can cause erratic operation.

Fuel Inlet Line

Fitech recommends using a -06 inlet line from the tank to the pump. From the pump to the engine a -06 line is also suitable. The hose and hose fittings supplied in this kit are suitable for plumbing your system as shown in the various illustrations.

Using a -06 line from the tank may require installing a larger pickup in the tank. Some stock tanks have a 5/16" diameter fuel tube. This is too small. The outlet line from the tank should be a minimum of 3/8" in diameter. The -06 supplied fuel hose will work on a 3/8" tube. If your current tank has a 5/16" fuel line coming from the sending unit, do some online searching (search "fuel sending units") for a replacement sending unit with a larger fuel line. Vehicles originally equipped with small block engines typically have 5/16" lines while big block engines have a 3/8" fuel line. If your model car was available with both small and big block engines there should be a 3/8" sending unit available. Note that some of these sending units have both an outlet and a return fuel line provision.

If you cannot source a sending unit with a 3/8" fuel line you will need to have one custom installed in your tank. This should be accomplished by an experienced professional who can modify your fuel tank.

Since the line from the tank to the pump is low pressure you can secure the -06 hose to the tank with a supplied hose clamp. The rest of the connections are made with the supplied special fittings and clamps.

Mounting and Plumbing the Fuel Pump and Pre-Filter

Select a location for mounting the pump. Be sure to provide enough space between the tank and the pump to allow for the pre-filter. The pump and filter should be mounted as low as the lowest portion of the fuel tank. They should also be mounted within three feet of the tank. This is important to avoid premature pump failure.

This kit includes a billet mounting bracket for the pump. Using the bracket as a template, mark two mounting holes on the frame (if that's where the pump will be mounted) and drill 4 MM holes for #10 self tapping metal screws. Mount the bracket to the frame using #10 self tapping sheet metal screws or other suitable hardware.

Note that the pump is directional and must be positioned with the wire terminals facing the front of the vehicle. Slip the fuel pump into the bracket and clamp it securely. See Figure 4.

Find a suitable location for the filter positioned between the tank and the pump. Mount the filter to the frame using the supplied Adel clamp. Again, drill a 4MM hole and use a #10 self tapping screw to hold the clamp.

Measure out the necessary lengths of the -06 hose to run from tank to the filter and from the filter to the pump. Cut the hose cleanly using a sharp blade. Make sure the ends are cut square. Push the hose onto the fitting placing a hose clamp over the hose. Tighten hose clamp securely. It will ease installation by using some WD-40 or similar lubricant sprayed on the hose nipple when installing the hose.

Connect the hose from the tank to the filter and a second hose from the filter to the pump.

Plumbing from the Pump to the EFI

The next step is to determine the lengths of the -06 hose which will run from the pump to the post-filter and then a second hose from the filter to the inlet port of the FiTech EFI system throttle body.

Note that the post-filter can be located anywhere between the pump and the throttle body. This filter is very light and can be supported by the fuel hose. No mounting clamp should be required but you will need to provide some type of support for the fuel line at several points between the pump and the engine compartment. It can be tie-wrapped or held in place with small Adel clamps. (Not supplied)

The FiTech EFI Throttle Body has three inlet ports and one outlet port. The outlet port is marked "Return." Select one of the three inlet ports and install a supplied -06 AN inlet fitting (Item 13). The return port requires a special fitting which is already installed in the throttle body. Install the supplied plugs in the two unused ports. You will have one plug left over. This is required when using the Fuel Com-

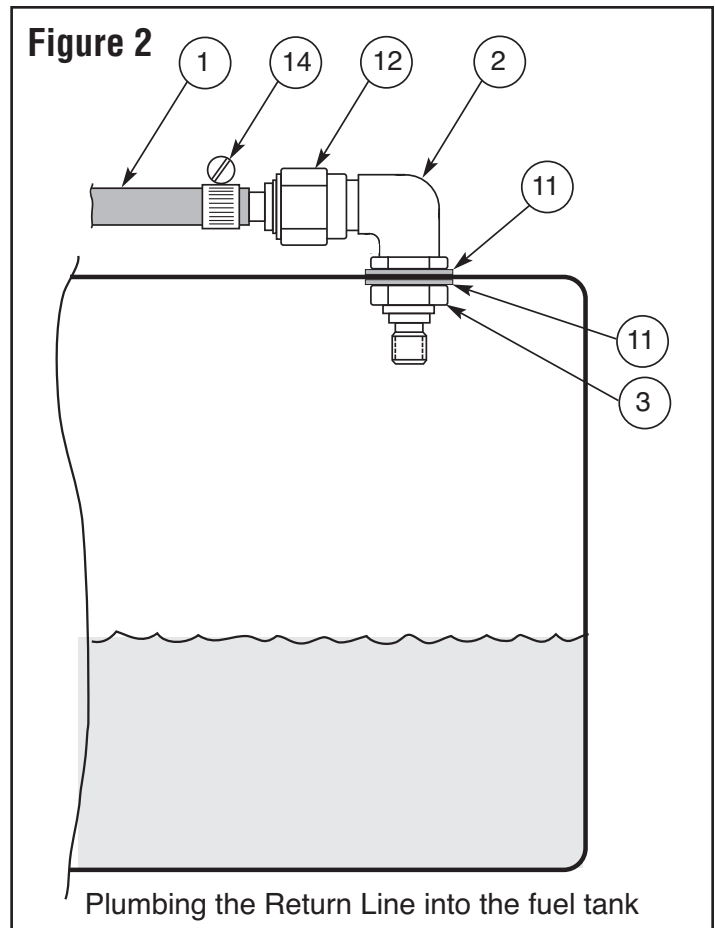

Plumbing the Return Line into the fuel tank



This Moroso Kit allows you to splice in a return line nipple into the filler neck of your gas tank.

Figure 3

mand Center which is returnless and the return port is also plugged. See Figure 5 on the next page.

Connect the -06 fuel hose from the filter to the inlet fitting on the throttle body. See Figure 1. Secure with a hose clamp.

Wiring the Fuel Pump

The FiTech ECU mounted on the throttle body has a small sub harness that is connected to it. In this sub harness is a large orange wire. Extend that wire and connect it to the positive (+) terminal on the fuel pump. Connect one end of a ground wire to the (-) terminal of the fuel pump and attach the other end to one of the screws holding the pump to the frame. Make sure the wire terminal makes contact with bare metal.

Where is the Fuel Pressure Regulator?

You may wonder why no fuel pressure regulator is used. That's because the FiTech System throttle body contains an internal fuel pressure regulator that maintains fuel pressure into the system at a constant 58 PSI.

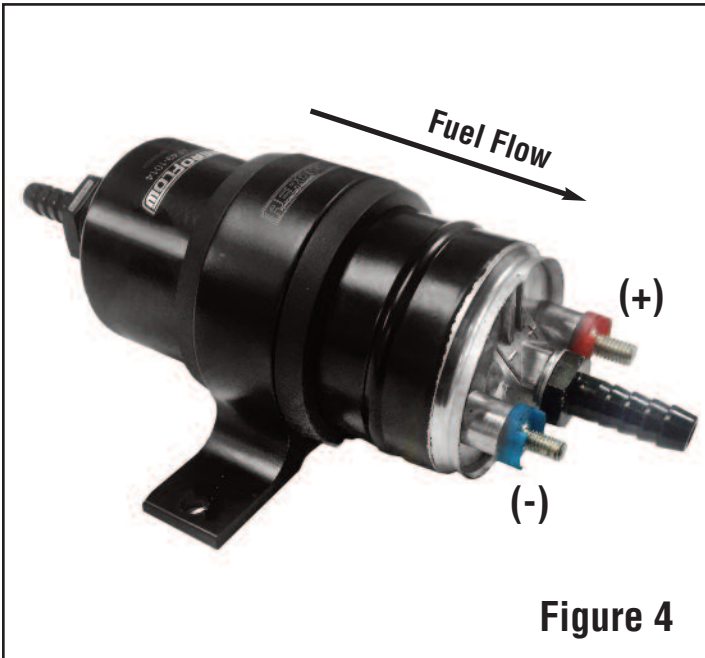

Figure 4

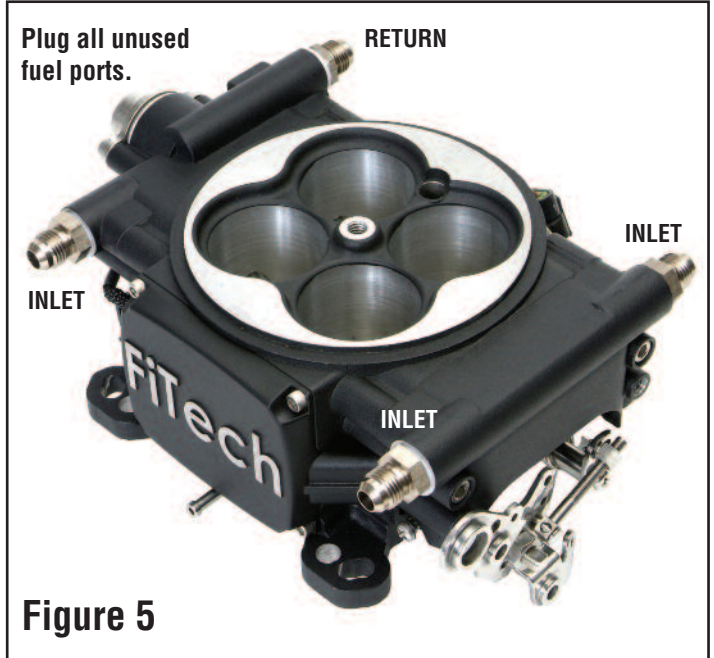

Figure 5

Completing the Installation

Once the entire installation is completed, turn on the main ignition switch which will activate the fuel pump. Immediately examine every connection checking for fuel

leaks. If any leaks are detected, turn off the ignition switch and repair all leaks. It is critical that no fuel leaks exist which could lead to a fire.



Figure 6

Figure 4 - Shown is the supplied 255 L/PH Fuel Pump.
Figure 5 - This photo shows the various Inlet Ports and the Return Port on the Throttle Body.
Figure 6 - Shown is the complete 50001 Fuel Delivery Kit with all the supplied components.

Adjusting Fuel Pump Pulse Width Modulation

Did you know that you can control the pulse width modulation (speed) of your fuel pump with your hand controller? If you are using the Inline Frame Mount Fuel Pump Kit (#50001) we recommend that you change the preset speed of the pump for best operation. To do this, follow these simple steps:

Step 1: Plug your handheld controller into the ECU on the FiTech Throttle Body, turn your key to the power system, but do not crank.

Step 2: Go to main menu, scroll down to Option 4: Go to EFI Initial set-up, and click the joystick to enter. See Figures 7 and 8.

Step 3: Go under option 1: Engine Setup. Then, scroll down to Option 6 (Pump PWM/FCC) and select edit, press clear (CLR) and enter a new value. The lower the number the slower the pump will run. For the #50001 Frame Mount Fuel Pump the recommended value for you to enter is 60. Press ok, then in the fuel pump control menu press the center of the control stick to send the change to the ECU. Figure 9.



Figure 7

Figure 8



Figure 9



Step 4: Lastly, turn the key off and wait 15 seconds for the system to power down (the screen will flash black) and once this is complete you may now start the engine and verify your change.

What does Pulse Width Modulation do for me?

With Pulse Width Modulation, the speed of your fuel pump runs very slowly at idle and low engine speeds but still provides the required amount of fuel. This slow speed reduces the noise made by any electric pump dramatically. Also running at a slower speed keeps the pump from heating up and extends the overall life of the pump.

And when the engine speed increases, so does the speed of the pump, always providing the required amount of fuel for all rpm ranges. While you can set the PWM to any desired number, we recommend that you use a setting of 60 for your Inline Fuel Pump.

Figure 10

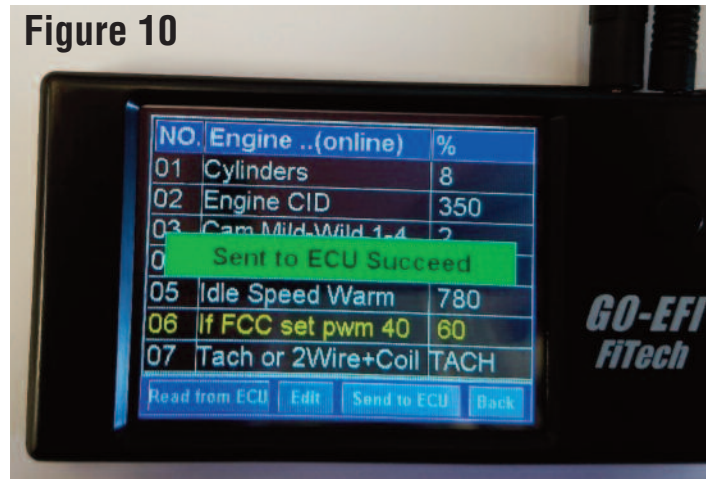

FiTech Fuel Injection

12370 Doherty Street • Riverside, CA 92503

Tech Phone: 951-340-2624

www.FiTechEFI.com