



## Installation Instructions Billet/Plus™ Short Throw Shifter

Fits 2005-2013 Corvette (including ZO6) with 6-Speed (C6)  
& 2014-2015 Corvette with 7-Speed (C7) Manual Transmission  
HURST # 3915086

**WORK SAFELY!** For maximum safety, perform this installation on a clean, level surface and with the engine turned off. Place blocks or wedges in front of and behind both rear wheels to prevent movement in either direction. Read this instructions sheet completely before installation. We highly recommend you use the appropriate factory service manual along with these instructions for additional procedure details.

**CAUTION:** To avoid any possibility of bodily injury or damage to vehicle, do not attempt installation until you are confident that the vehicle is safely secured and will not move.

### FACTORY CONSOLE REMOVAL

1. Open console door and remove the T15 Torx head screws on the underside of the console door and remove door.

2. Remove parking brake boot by pulling directly upward on inner and outer edge of boot to release from console (NOTE: there are two (2) retaining clips on the inside edge), then slide boot up and off of handle. Using a 7mm socket or T-15 Torx, remove two (2) console trim screws on the passenger side from area under boot (See Figure 1).

3. Separate passenger side console trim from instrument panel trim by pushing downward slightly at rear of side trim. Remove passenger side console trim from dash by pulling downward away from dash (See Figure 1). Replace clips onto trim if they remain in dash.

Figure 1

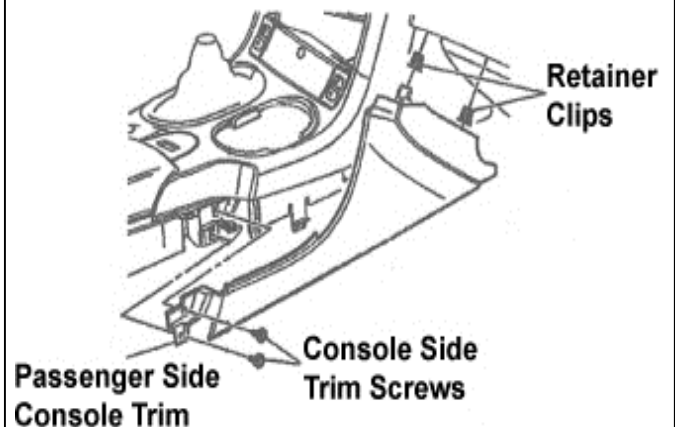

4. Lift access panel (located immediately in front of console) by pulling upward on rear to release from mounting clips (use a flat blade screwdriver under rear edge if necessary). If applicable, disconnect wiring from "Airbag Off" light by inserting small screwdriver into connector to release tab, or remove switch from panel via latch on each side. Disconnect Mag SRC switch connector if applicable. Remove two (2) screws from rear, connecting console to instrument panel trim (See Figure 2).

Figure 2



Using a 10mm socket, loosen bolt located inside panel opening by a few turns. Bolt removal is not necessary (see figure 3).

5. Using a small flat blade screwdriver, remove the plastic covers at the rear of the console to allow access to the retaining nuts (See Figure 3). Using a 10mm socket, remove the hex nuts that fasten the rear of the console to the floor tunnel. Lift rear of instrument panel trim slightly while lifting the rear of the console to clear the studs and pull toward rear.

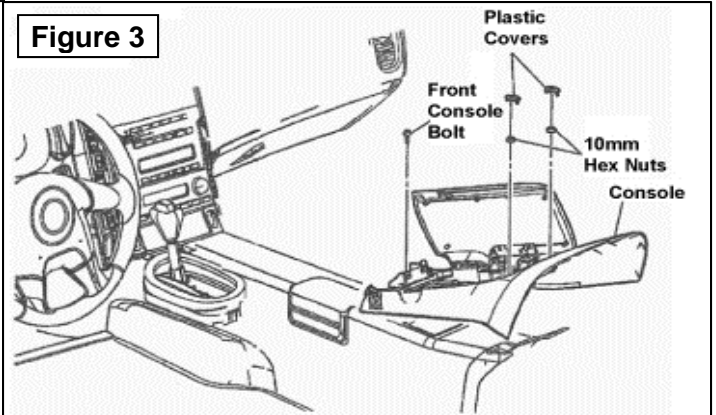

### **INSTRUMENT PANEL TRIM PLATE REMOVAL**

1. Pull the leather shift boot down below the shifter knob to reveal a Torx head screw on the driver's side of the knob. Using a T20 Torx bit, remove the screw and slide the knob up and off the shifter.

2. Place shifter in 2nd gear. Remove instrument panel trim by pulling upward and toward the rear. Disconnect the following wires: console power outlet, traction control switch, right and left heated seat switches (if applicable), cigarette lighter socket, and hazard warning switch. Alternatively, the console power outlet and traction control switch connectors can remain attached and you can set the instrument panel trim on the passenger seat.

**NOTE: Protect seat with cover to avoid scratching and marring.**

### **FACTORY SHIFTER REMOVAL**

1. Remove boot cover from front and rear retaining tabs on closeout boot. Using a 10mm socket, remove the four (4) hex nuts that retain the closeout boot to the floorpan. Carefully pry boot up and remove.

2. Place shifter into neutral. Remove the four (4) 3/8" hex head bolts that retain the factory shifter base to the housing and remove shifter base to the housing and remove shifter assembly by lifting up and out.

**NOTE: Grasp the alignment pin located on the front of the shifter base and remove while lifting shifter out.**

3. Carefully pry off the plastic cup bushing from the end of the factory shifter and set aside for re-installation.

## **BILLET/PLUS SHIFTER INSTALLATION**

1. Remove factory rubber gasket from shifter housing (this will not be reused). Clean mounting surface.
2. Place new mounting gasket (supplied) onto shifter housing.
3. Place the plastic cup bushing that was removed from the factory shifter open end up on a workbench. Put a small amount of grease on the ball end of the Hurst Billet/Plus stick bottom, and place the ball in the open end of the cup bushing. Gently push down on the stick bottom until the ball snaps into the bushing.
4. Install the Hurst Billet/Plus shifter onto the shifter housing making sure that the cup bushing on the stick bottom fits properly into shift selector socket inside the housing.

**IMPORTANT: The shifter must be installed with the machined flat in the shifter stick threads facing forward.**

5. Install the four (4) socket head screws (supplied) to secure the mounting base to the shifter housing using a 3/16" hex key wrench. Tighten evenly to 8-10 lbs.ft. torque.

**IMPORTANT: Make sure that shifter base is sitting flush onto housing before tightening screws.**

6. Test shifter operation. Move the stick through the entire gearshift pattern making sure that it engages each gear fully and the stick moves freely from side to side in "neutral" position.

## **ADJUSTMENT OF OPTIONAL SHIFTER STOP SCREWS**

**IMPORTANT! The T-56 transmission contains built-in gear stops. The adjustable stop screws on the shifter are optional and should be removed if not used. These stops are advantageous during gear changes where significant force is used like in racing environments. If the shifter stops are retained, it is very important to adjust the stops exactly as instructed.**

7. Adjustment procedure: Remove stop screws and apply thread locker (supplied) liberally to entire thread length. Insert screws until they are flush with the inside of the aluminum base. Pull stick firmly into 2nd gear and hold securely. Turn rear stop screw in until head contacts stick, then back screw out 1/4 turn. Hold screw secure with a 3/16" hex key wrench and tighten jam nut using a 9/16" wrench. Repeat adjustment on forward stop screw. Push stick firmly into 3rd gear and hold securely. Turn front stop screw in until head contacts stick, then back screw out 1/4 turn. Hold screw secure with hex key wrench and tighten jam nut.

## **OPTIONAL BIAS SPRING ADJUSTMENT/REPLACEMENT**

If desired, shifter stick "side to side" tension can be tailored to driver preference and comfort by adjusting or changing the bias springs. Using a 1/4" hex key wrench, turn the hex socket screws on top of the shifter base clockwise to increase tension or counter-clockwise to decrease tension.

**IMPORTANT: Do not turn adjuster screws more than 1 full turn in either direction from the factory preset.**

If more or less tension is desired and cannot be achieved by adjusting the screws, there are two (2) sets of additional bias springs supplied with this shifter that can be used to replace the ones installed at the factory. To change the springs, remove the adjustment screws. Each side has an inner and an outer spring, the softer inner and stiffer outer spring are factory installed. You can mix and match combinations of the springs to obtain the desired tension.

Clean the threads on the adjuster screws and apply a few drops of thread locker (supplied) to the threads. Reinstall the screws and turn in approximately 3 and 1/2 full turns as a starting point. NOTE: Whenever the bias spring screws are adjusted, it is recommended to apply thread locker to the threads to keep screws in place and maintain spring tension.

8. In order for the closeout boot to properly fit around the Billet/Plus shifter base, you must modify the closeout boot. Using a sharp utility knife, carefully cut out the inner portion of the factory closeout boot around the inner edge of the raised rib to match the diameter of the Hurst shifter base. Re-install the factory closeout boot and replace the four (4) 10mm hex nuts previously removed. Tighten securely. Reinstall factory boot cover and attach to front and rear tabs on closeout boot.

## **INSTRUMENT PANEL TRIM AND CONSOLE REPLACEMENT**

1. Place shifter in 2nd gear. Reposition instrument panel trim by first reconnecting all electrical connectors, which may include: console power outlet, traction control switch, right and left heated seat switches (if applicable), cigarette lighter socket, and hazard warning switch. Carefully align and lower trim plate over shifter. Align the trim plate locking tabs to their respective slots in the dash and carefully begin pushing the tabs into the slots from the top down.

2. Carefully re-install the console onto the floor tunnel studs making sure that the front of the console is positioned under the front mounting bolt within the rear area of the instrument panel trim plate. Install and tighten rear hex nut with a 10mm socket and replace the nut access covers. Tighten front bolt inside instrument panel trim area with a 10mm socket.

3. Push rear of instrument panel trim down into proper position and install the two (2) screws fastening the console to the instrument panel trim and tighten using a 7mm socket. Reconnect passenger "Airbag Off" light connector and Mag SRC switch connector (if applicable). Reinstall access panel by aligning front and pressing down on rear clips.

4. Replace passenger side console trim by first aligning the locking tabs in the dash. Push upward into dash to lock tabs. Be careful to properly fit side trim with instrument panel trim while moving upward into place. Install and tighten the two (2) passenger side console trim screws using a 7mm socket. Reinstall parking brake boot by aligning outer tabs and pushing down on inside clips.

5. Replace console door and attach with four (4) T15 Torx head screws previously removed.

6. Install factory shift knob onto new Hurst shifter stick and push down until fully seated. Fasten knob to shifter stick with T20 Torx head screw previously removed and tighten securely. Pull leather shift boot up and work into groove on bottom of knob.

**IMPORTANT: RETAIN THESE INSTRUCTIONS FOR FUTURE REFERENCE**

**Technical Service**

A highly trained technical service department is maintained by Hurst Performance to answer your technical questions, provide additional product information and offer various recommendations.

Technical service calls, correspondence, and warranty questions should be directed to:



**Hurst Performance Products**

(707) 544-4761

[www.Hurst-Shifters.com](http://www.Hurst-Shifters.com)