



GEN3 Hemi Swap Engine Mounts
1973-1976 A-Body Mopar with Stock (Non-Hemi) V8 K-Member
5.7-6.1-6.2-6.4L Engines
BHS571
Installation Instructions



Thank you for choosing to use Hooker Blackheart™ engine swap mounts as part of your GEN3 HEMI Swap project. These mounts are part of the most comprehensively engineered system of mounting components, headers and exhaust systems available for this application. Please read these instructions thoroughly before attempting installation.

IMPORTANT:

- **Low mount A/C Compressors will only work with engines using VVT front accessory drive.**
*** These engine mounts will not work with **NON-VVT** low mount A/C compressor configurations.
- Column shift vehicles with manual steering will require modifications to the steering column tube and shift linkage bracket for valve cover clearance.

PRE-INSTALLATION CONSIDERATIONS:

- Mopar **90 degree oil filter adapter PN: 04893315AC** or remote oil filter location will be required.
- Use of a Mid Sump oil pan and pick up tube required (**Holley PN: 302-61 VVT or PN: 302-60 NON-VVT** - See www.holley.com for a complete selection of Hemi Swap oil pans and pickup tubes)
NOTE: Some K-members require minor clearance for oil pan fitment.
- 6.2L Hellcat engine installations may require supercharger water manifold – **PN: HEMI0005ERL.**
- Only Blackheart Headers **PN: BH23104** headers have been tested for correct fitment with these engine mounting plates.

Visit www.holley.com for a complete selection of transmission crossmember, headers, exhaust, and more GEN3 HEMI support products to complete your A-Body Hemi Swap.

COMPATIBILITY INFORMATION:

PN: BHS571 Engine Mounts will not work with the following combinations:

- Low mount A/C Compressors on **NON-VVT ENGINES** - (VVT timing cover and accessory drive is required to use low mount A/C)
- OEM Hemi K-Members
- 6 Cylinder K-Members
- Early K-Members using pad style engine mounts (67-72)

PARTS LIST:

Qty.	Description
1	Left Engine Mount
1	Right Engine Mount

ACCESSORY PACK CONTENTS

8		M10 x 1.50 x 25mm Flange Bolts
2		1/2"-20 x 5" Bolts
2		Lock Nuts
4		Flat Washers
1	199R12169	Instruction Sheet

Check the hardware package. If anything is missing, please contact Technical Service at 1-866-464-6553 or 270-781-9741.

TOOLS NEEDED:

3/8" Metric Socket Set
6' Extension
3/4" Wrench
13mm Wrench
3/4" Socket

INSTALLATION OF BHS571 GEN 3 HEMI SWAP ENGINE MOUNTS:

Driver's Side Mounting Plate

- With the engine out of the vehicle, install the driver's side (Left) engine mount to the engine block using (x4) M10 x 25mm flange bolts provided. Install the mount with the polyurethane mount toward the front of the engine using the OEM engine mount locations on the engine block. **NOTE:** The 5th mounting hole provided may be used in place of the 4th bolt under the motor mount pad, if the block is threaded. **NOTE:** Always use at least 4 mounting bolts (**Figures 1 & 2**).

Drivers Side (Left) Mounting Plate

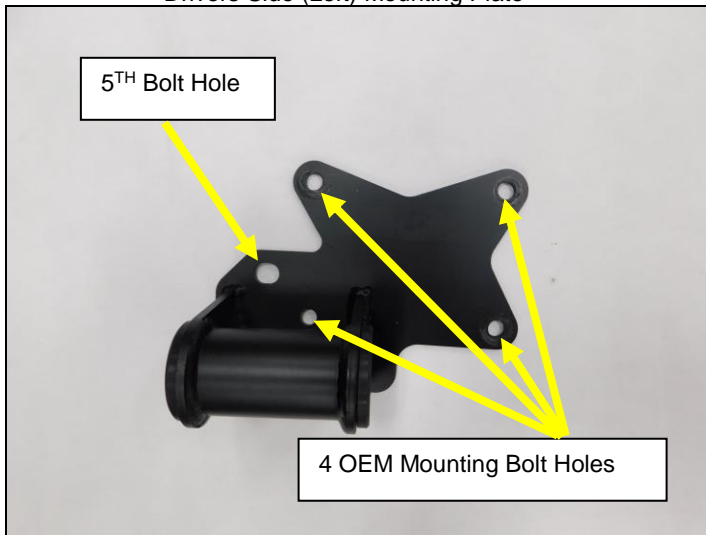

Figure 1

Drivers Side (Left) Mounting Plate Installed

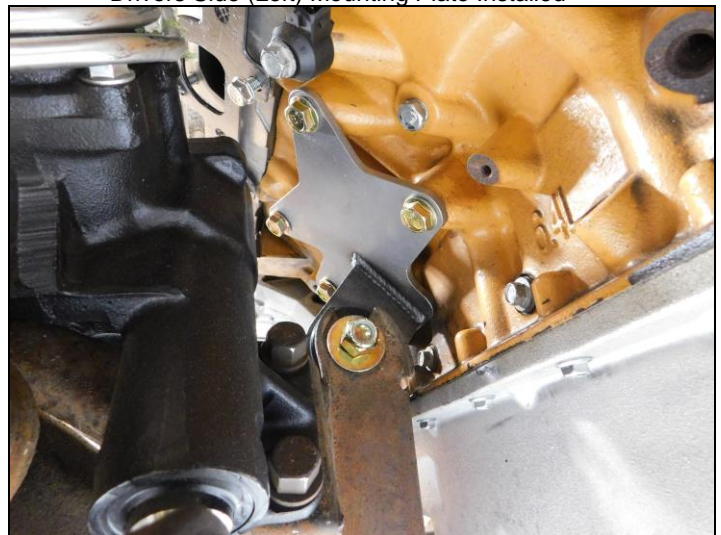

Figure 2

Passenger's Side Mounting Plate

- With the engine out of the vehicle, install the driver's side (Left) engine mount to the engine block using (x4) M10 x 25MM flange bolts provided. Install the mount with the polyurethane mount toward the front of the engine using the OEM engine mount locations on the engine block. **NOTE:** Always use at least 4 mounting bolts (**Figures 3 & 4**).

Passenger's Side Mounting Plate

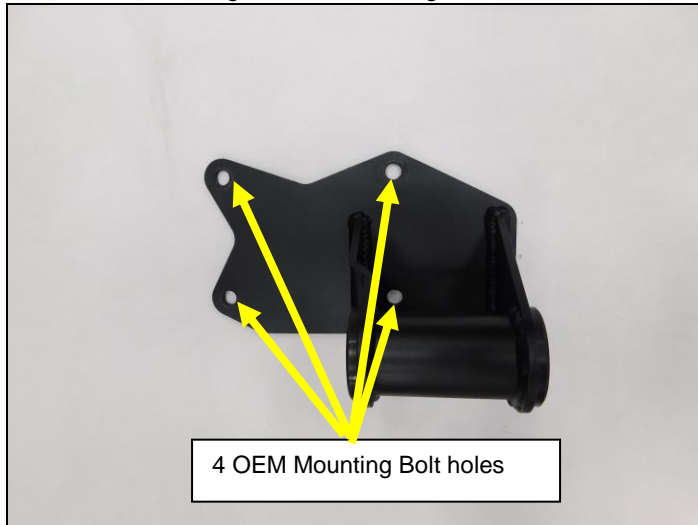

Figure 3

Passenger's Side Mounting Plate Installed



Figure 4

- Install the 1/2" x 5" bolt with one flat washer into the engine mount. Install the bolt into the mount from the front for the left and right mounts. Install a second flat washer and locking nut on to the bolt.
- Slowly lower the engine onto the mounts being careful not to get the polyurethane bushing or flat washers caught on the edge of the engine mounting stand as the mount passes into the stand.
- Check be sure the bolt is seated in the stand completely and tighten the nut.
Note: Support the engine while the transmission is being installed to avoid damaging the polyurethane bushing

Any questions? Please contact Technical Service: 1-866-464-6553 or 270-781-9741. For online help, please refer to: www.holley.com.

© 2021 Hooker Headers, Inc. All rights reserved. Tous Droits Réservés.

199R12169
Date: 3-4-21