



8511HKR	LS Turbo Exhaust Manifold – Driver’s Side - Natural w/ Clamp
8512HKR	LS Turbo Exhaust Manifold – Passenger’s Side - Natural w/ Clamps
8510HKR	LS Turbo Exhaust Manifold Set – Both Driver’s & Passenger’s Sides – Natural w/ Clamps
8511-1HKR	LS Turbo Exhaust Manifold – Driver’s Side – Silver Ceramic w/ Clamp
8512-1HKR	LS Turbo Exhaust Manifold – Passenger’s Side – Silver Ceramic w/ Clamps
8510-1HKR	LS Turbo Exhaust Manifold Set – Both Driver’s & Passenger’s Sides – Silver Ceramic w/ Clamps

WARNING! This product is not street legal and may only be used on Racing Vehicles. Racing Vehicles must be used exclusively for racing or other forms of competition. Racing vehicles must not be registered and must never be used on the street. It is illegal to install this product on a registered vehicle and use it on the street.

NOTE: The manifold(s) fits most swap applications. See dimensional drawings below to confirm fit. The manifolds clear Hooker engine mounts. If using 12622HKR, 12611HKR, 12623HKR, and 12624HKR or similar designed swap plates, some modification to the attached engine mount may be required to clear the manifold. Not compatible with 2004-2006 GTO starters/bellhousings.

Contents for 8510HKR & 8510-1HKR:		Contents for 8511HKR & 8511-1HKR:		Contents for 8512HKR & 8512-1HKR:	
Qty.	Description	Qty.	Description	Qty.	Description
1	Passenger’s Side Manifold	1	Driver’s Side Manifold	1	Passenger’s Side Manifold
1	Driver’s Side Manifold	1	2.25” Stainless Steel V-Band Clamp	1	3” Stainless Steel V-Band Clamp
1	3” Stainless Steel V-Band Clamp	1	2.25” Stainless Steel V-Band Flange	1	3” Stainless Steel V-Band Flange
1	3” Stainless Steel V-Band Flange	6	Flanged Head M8 x 1.25 x 25 Bolts	1	2.25” Stainless Steel V-Band Clamp
2	2.25” Stainless Steel V-Band Clamp	1	Instruction Sheet	1	2.25” Stainless Steel V-Band Flange
2	2.25” Stainless Steel V-Band Flange	1	Hooker Decal	6	Flanged Head M8 x 1.25 x 25 Bolts
12	Flanged Head M8 x 1.25 x 25 Bolts			1	Instruction Sheet
1	Instruction Sheet			1	Hooker Decal
1	Hooker Decal			2	1.5” ID Black Thermal Tubes
2	1.5” ID Black Thermal Tubes			1	Form-A-Shield
1	Form-A-Shield			1	

CROSS-OVER PIPES AVAILABLE SEPARATELY:

8513HKR	LS turbo cross-over tube w/v-band flanges - Trans T56 w/ Quick Time Bell-Housing
8514HKR	LS turbo cross-over tube w/v-band flanges - Trans GM PG, TH350/TH400
8515HKR	LS Turbo Cross-Over Tube w/ V-Band Flanges - Trans 4L60/4L80
8516HKR	LS Turbo Cross-Over Tube w/ V-Band Flanges - Universal Comp Kit
8517HKR	LS Turbo Cross-Over Tube w/ V-Band Flanges - Trans T56 w/ OEM Bell-Housing/6L80

Thank you for making HOOKER™ HEADERS your choice in high-performance exhaust system components.

These Hooker™ cast exhaust manifolds have been designed to fit into a wide variety of replacement and engine-swap applications. These products do not have a C.A.R.B. Executive Order Exemption and therefore may or may not be legal for any particular pollution controlled application. The casting is a High-Silicon-Moly ductile iron material and will provide trouble-free service for street/performance LS engines.

A single 2-1/4" x 2.5" radius U-bend (not included) can usually provide sufficient bend material to route the exhaust around any close-proximity components such as lower control arm frame perches.

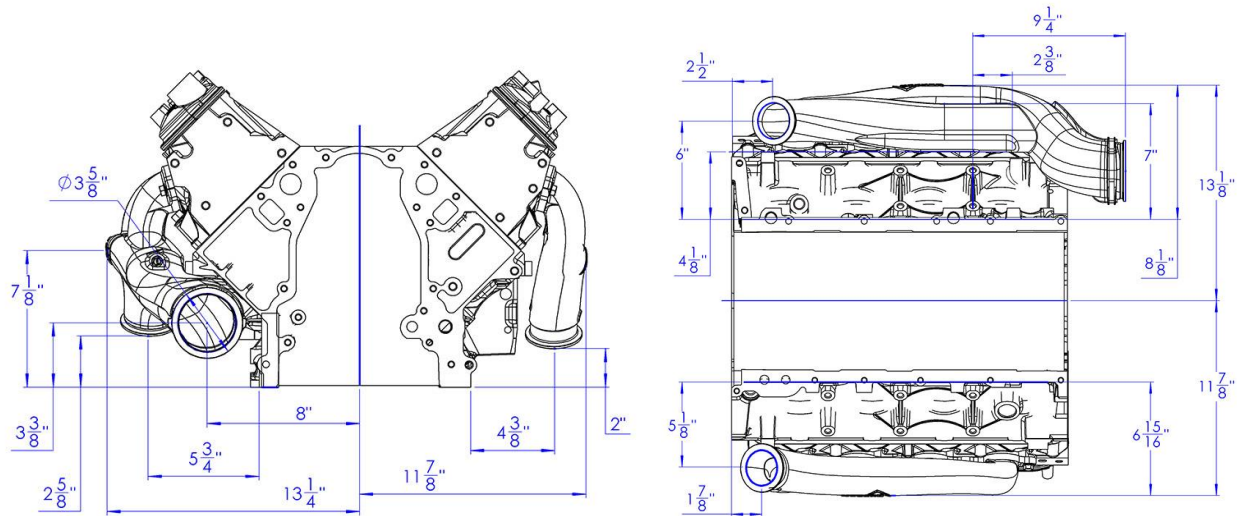

WARNING! Breaking in an engine with ceramic-coated versions of these manifolds will most likely result in damage to the coating and VOID all warranties providing coverage to it. HOOKER™ recommends using bare cast-iron manifolds or an old set of headers to break-in engines to avoid coating damage.

Ceramic-coated manifolds require several heat cycles to fully cure before they will withstand extreme heat, so care should be taken to provide a series of 4 to 5 intermittent heat cycles to “set” the coating prior to putting the vehicle into service. An incremental increase in run duration and throttle angle should be added to each successive cycle; initial and final run durations between approximately 1 and 7 minutes will be sufficient to set the coating.

CAUTION! When working under your car, be sure to properly support it with jack stands or ensure the locks on your vehicle lift are engaged if using one. NEVER WORK UNDER A CAR SUPPORTED BY A BUMPER JACK OR HYDRAULIC LIFTING JACK!

INSTALLATION PROCEDURE

IMPORTANT! Thoroughly clean all components before assembly to remove any/all contaminants.

1. Disconnect the negative battery cable.
2. Remove the spark plug wires.
3. Remove the spark plugs, if it appears necessary to be able to remove the existing manifolds/headers from vehicle.
4. Remove the engine oil dipstick tube from the passenger's side of the engine.
5. Disconnect any exhaust components connected to the outlet of the existing manifolds/headers.
6. Remove the existing manifolds/headers from the engine.
7. Install the Hooker™ cast iron manifold(s) to the engine using stock GM gaskets (or P/N 4805G Mr. Gasket) and the supplied bolts. Only hand-tighten bolts at this time.
8. After installing the manifold(s), inspect clearances to surroundings. Manifolds can reach very high temperatures. A section of shielding (DEI Form-A-Shield™) is supplied and additional can be purchased at: <http://www.designengineering.com/category/catalog/design-engineering-inc/heat-sound-barrier/form-a-shield>

CAUTION! Form-A-Shield™ may cause temporary irritation. Protective eye wear, dust mask, and gloves are highly recommended. Avoid inhalation of loose fibers AND avoid skin contact with fibers.

9. Apply this shielding directly to a hot surface of the manifold. The insulation side is in contact with the hot surface. It can also be used as a reflective barrier shield (the dimpled aluminum faces the heat source).

NOTE: In some cases, engine mounts may be close enough to the manifold(s) for heat to affect the bushing/insert material. If this is the case, solid engine mounts are recommended.

10. Attach the cross-over from the driver's side manifold to the passenger's side manifold using the supplied V-band clamps.

NOTE: Torque all manifold bolts to 15 ft./lbs. at this time.

11. Mount the turbo solidly so that the weight of the turbo is supported independently from the turbo connection.

12. Fabricate the connection from the manifold to the turbo. Leave ample distance between wires, rubber lines, fuel lines, and plastics to reduce the chances from heat damage.

13. Reinstall the engine oil dipstick tube and spark plug wires/spark plugs.

14. Fabricate the down pipe. Leave ample distance between wires, rubber lines, fuel lines, and plastics to reduce the chances from heat damage.

15. Install supplied black thermal insulation tubes to heater hoses at the manifold end and connect to the water pump.

16. Reconnect the negative battery cable to the battery.

17. Start the vehicle and check for leaks. If the installed manifolds are ceramic coated, perform coating set thermal cycling procedure recommended previously in this document.

Stock GM part number reference list:

- | | |
|------------------------------------------|-----------------------------------------|
| Exhaust manifold to cylinder head gasket | - 12617944 (1 per side required) |
| Works with most GM LS dipsticks/tubes | - Dipstick (12634547 suggested) |
| | - Tube (12625031 suggested) |

Hooker Technical Support: 1-866-464-6553

© 2017 Holley Performance Products, Inc. All rights reserved.

199R11188

Revision Date: 5-11-17