



## P/N 300-225 – Holley LS Hi-Ram Intake Manifold Mounting Stud Kit

### Contents:

- Stud, M6 x 1.0 Threads, Intake Manifold to Cylinder Head Mounting, qty-10
- Washer, M6 x 12mm O.D x 1.6mm Thick, Intake Manifold to Cylinder Head Mounting, qty-10
- Nut, M6 x 1.0 Threads, Intake Manifold to Cylinder Head Mounting, qty-10

### INSTALLATION INSTRUCTIONS

(Before installation, please read these instructions completely.)

1. Before installing the intake manifold base, perform a test fit of the intake manifold without the o-rings installed. Make sure that the mounting studs (supplied) can thread freely into the cylinder heads through the intake manifold mounting holes. The mounting flanges should seat properly. Check the port opening alignment. Test fit the plenum top, fuel and vacuum plumbing, throttle linkage, wiring, etc. to ensure there are not any fit issues before performing the final intake manifold installation.
2. For final installation, install the eight o-rings provided in the mounting flange o-ring grooves. To make sure the o-rings do not fall from the grooves apply a light coat of grease to the o-rings.
3. Install the mounting studs into the cylinder heads. The end with the shorter length of thread goes into the cylinder heads. Apply engine oil to the threads and thread in the stud until all of the threads are engaged by hand.
4. Place the manifold base in place on the mounting flange. Be sure that all of the o-rings are still in the grooves and are not being crushed between the flanges.

**WARNING! The M6x1 threads in the aluminum cylinder head will not withstand abuse. Care must be taken to have proper thread engagement and to tighten the fasteners to the proper specifications.**

5. Install the washers and nuts provided; engine oil should be applied to the threads. Gently tighten the nuts working side to side and out from center (see the tightening sequence diagram below), until manifold is seated on the mounting flanges and the o-rings have been compressed. In two steps, tighten the mounting nuts first to 50 in-lbs and then to 106 in-lbs following the tighten sequence diagram below.

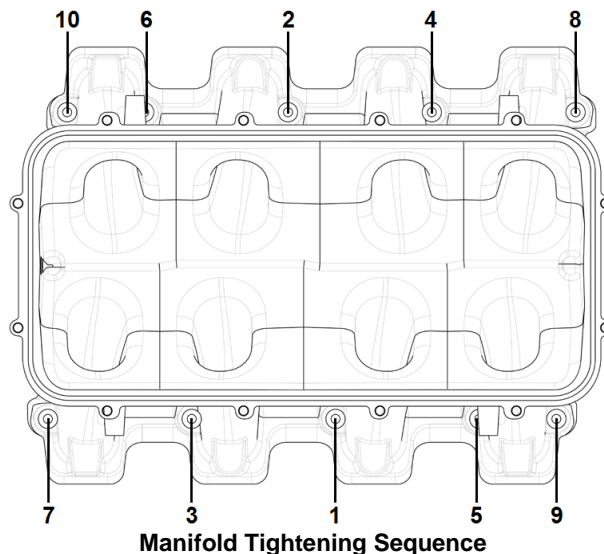

Technical Support: 1-866-GOHOLLEY