



Holley® LS Modular Mid-Rise Intake Manifold Kits and Mid-Rise Plenum Base Adapter for Custom EFI Intake Manifold Installations

Holley P/N	Description
300-126 / 300-126BK	LS1 Modular Mid-Rise Intake Manifold Kit
300-135 / 300-135BK	LS3 Modular Mid-Rise Intake Manifold Kit
300-231 / 300-231BK	Mid-Rise Plenum Base Adapter Kit

INSTALLATION INSTRUCTIONS 199R10612

(Before installation, please read these instructions completely.)

NOTE: Holley EFI LS main harnesses have a map sensor connecter designed for use with an LS1/2 style map sensor. The 558-416 is an adapter harness that can be used to adapt any LS harness that uses a LS1/2 MAP sensor connection to a LS3 MAP, which is recommended for this manifold.

APPLICATIONS:

The Holley® Mid-Rise plenum base adapter allows the installation of a 300-218 (92mm throttle body opening) or 300-219 (105mm throttle body opening) Hi-Ram plenum top (front mount LS 4-bolt throttle body) on Holley LS dual plane mid-rise (2x4) EFI intake manifolds 300-121 (LS1) or 300-134 (LS3). Depending on the application and engine geometry, the 300-231 Mid-Rise plenum adapter kit would allow an LS Hi-Ram 1 x 92mm or 1 x 105mm plenum top to be adapted to any dual-quad 4160 intake manifold that has a carb flange spacing of 8-5/8" (typical to an inline dual-quad Holley® 4160 carb installation). It should also be noted that any of the LS Hi-Ram plenum tops will mount on the Mid-Rise plenum base adapter.

The Mid-Rise style intake manifold kits are designed for stock to mildly modified engine applications up to 427 cubic inch displacement and engine speeds to 6500 rpm. The LS1 and LS3 Mid-Rise intake manifolds are custom intake manifold installations and will not accept all OE components. Please consult these installation instructions. Intake manifold-to-hood clearance may be an issue for some vehicle applications.

EMISSIONS EQUIPMENT:

Holley® Mid-Rise intake manifolds may not accept some emission-control devices. This part may not be legal for sale or use for motor vehicles with pollution-controlled equipment if the installation of this intake disables the installation or operation of any emission-control equipment.

DIMENSIONS:

NOTE: All heights measure to the lifter valley cover flange on the engine block. Unless otherwise stated, the dimensions and information applies to an installation of 300-126 on a LS1 engine or a 300-135 on a LS3 engine.

- Manifold Throttle Body/Plenum Adapter Flange A-B Heights:
300-121 (in 300-126) – A – 4.46" (front), B – 5.53" (rear).
300-134 (in 300-135) – A – 4.73" (front), B – 5.80" (rear).
- Plenum Mounting Flange A-B Height:
300-126 – A – 6.49" (front), B – 7.56" (rear).
300-135 – A – 6.73" (front), B – 7.80" (rear).
- Total Height with 92/105mm Long. Mount EFI Plenum Top:
300-126 – 10.44" (located 0.89" behind the front flange of the engine block).
300-135 – 10.67" (located 0.70" behind the front flange of the engine block).
- Throttle Valve Flange Location, with 92/105mm Long. Mount EFI Plenum Top:
300-126 – Height – 6.28", Longitudinal Location – 3.93 (forward from engine block front flange), Lateral Location – On-Center, Angle – 28 deg. (down from vertical).
300-135 – Height – 6.51", Longitudinal Location – 4.12 (forward from engine block front flange), Lateral Location – On-Center, Angle – 28 deg. (down from vertical).

- Plenum Base Adapter Thickness (from mounting flange to plenum top mounting flange) – 2.00”
- Port Size:
300-126 (300-121 base manifold) – 2.69” Height x 0.97” Wide. For other 300-121 intake manifold data, consult the installation instructions for 300-120/300-121, IS# 199R10577.
300-135 (300-134 base manifold) – 2.41” Height x 1.07” Wide. For other 300-134 intake manifold data, consult the installation instructions for 300-133/300-134, IS# 199R10692.
- Intake Manifold Mounting Flange Gasket Type:
300-126 – 3/32” Round Viton O-Rings, Size 2-151, 3” I.D. (included with the 300-121 intake manifold install kit).
300-135 – 3/32” Round Viton O-Rings, Size 2-146, 2-5/8” I.D. (included with the 300-134 intake manifold install kit).
- Plenum Base Adapter to Intake Manifold Gasket Type – Two .020” Thick Flat Composition Gaskets (included with the 300-231 plenum base adapter installation kit).
- Plenum Top Gasket Type – 3/32” Round Viton O-ring Cord (included with the 300-231 plenum base adapter installation kit).

300-126 INTAKE MANIFOLD KIT CONTENTS:

- 1 – 300-121 EFI Intake manifold, LS1 Mid-Rise, Dual-Plane, Dual Quad Intake Manifold
- 1 – 534-204 Fuel Rail Kit, Holley LS1 for 300-121 IM and LS1/2/6 Hi-Ram IM Kits (which includes)
 - 2 – Fuel Rails, High Volume, Configured with 3/4-16 O-ring Ports (AN-8)
 - 4 – 1/4-20 UNC x 1-3/4” Long Socket Head Cap Screws, Zinc Plated, Fuel Rail Mounting
 - 4 – Washers, 1/4 x .50” O.D x .06” Thick, Fuel Rail Mounting
 - 4 – Spacers, 1/4 I.D. x 1/2” O.D. x 3/8” Thick, Fuel Rail Mounting
- 1 – Intake Manifold Installation Kit labeled 85R9668 (which includes)
 - 10 – M6 x 1.0 x 50mm Long Hex Head Cap Screws, Zinc Plated, Class 10.9, Mounting Bolts
 - 10 – Washers, M6 x 12mm O.D. x 1.6mm Thick, Intake Manifold to Cylinder Head Mounting
 - 8 – O-Rings, 3/32” Dia. Round Sect. Viton, Size 2-151, 3” I.D., Port Flg. Seals, Holley Service P/N 508-23
 - 1 – 3/8 NPT Hex Socket Steel Pipe Plug
 - 1 – Installation Instructions, 300-120/300-121, IS# 199R10577
- 1 – 300-218 Plenum Top Kit, Longitudinally End-Mounted 92mm LS 4-bolt Throttle Body (which includes)
 - 1 – Machined Plenum Top, 1x92mm Long.-End-Mount LS 4-bolt TB
 - 1 – Throttle Body Gasket LS 4-bolt, Holley Service P/N 508-20
- 1 – 300-231 Plenum Base Adapter Kit (which Includes)
 - 1 – Machined Plenum Base Adapter
 - 1 – Plenum Base Adapter Installation Kit labeled 85R9713 (which includes)
 - 12 – 1/4-20 UNC x 7/8” Long Socket Head Cap Screws, Zinc Plated, Plenum Attachment Bolts
 - 8 – 5/16-18 UNC x 1” Long Socket Head Cap Screws, Black-Oxide. Plenum Base Adapter Attachment Bolts
 - 4.5 ft – O-ring Cord, 3/32” Dia. Round Section Viton, Plenum Flange Seal, Holley Service P/N 508-21
 - 2 – Gaskets, Plenum Base Adapter to Intake Manifold, 0.020” Thick Flat
 - 1 – 1/4 NPT Hex Socket Steel Pipe Plug
 - 1 – 1/8 NPT Hex Socket Steel Pipe Plug
 - 1 – Installation Instructions 300-126/300-135/300-231, IS# 199R10612
 - 1 – Warranty Card
- 1 – Warranty Card

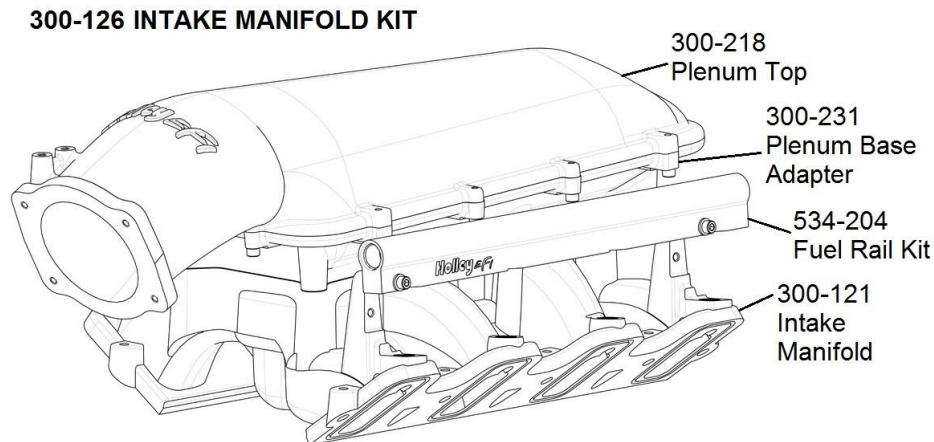

Figure 1

300-135 INTAKE MANIFOLD KIT CONTENTS:

- 1 – 300-134 EFI Intake manifold, LS3 Mid-Rise, Dual-Plane, Dual Quad Intake Manifold
- 1 – 534-220 Fuel Rail Kit, Holley for 300-134 IM (which includes)
 - 2 – Fuel Rails, High Volume, Configured with 3/4-16 O-ring Ports (AN-8)
 - 6 – Brackets, Fuel Rail, Bosch EV1 Type Fuel Injector
 - 6 – Brackets, Fuel Rail, GM LS7 Type Fuel Injector
 - 6 – Flanged Hex-Head Cap Screws, 5/16-18 x .50" Fuel Rail to Bracket Mounting
 - 6 – Flanged Hex-Head Cap Screws, 5/16-18 x .75" Fuel Rail Bracket to Intake Manifold Mounting
 - 8 – O-Rings, Fuel Injector Outlet (to adapt the LS7 fuel injector to the Holley manifold)
- 1 – Intake Manifold Installation Kit labeled 85R9744 (which includes)
 - 8 – M6 x 1.0 x 70mm Long Hex Head Cap Screws, Zinc Plated, Class 8.8, Mounting Bolts
 - 2 – M6 x 1.0 x 100mm Long Hex Head Cap Screws, Zinc Plated, Class 8.8, Mounting Bolts
 - 10 – Washers, M6 x 12mm O.D. x 1.6mm Thick, Intake Manifold to Cylinder Head Mounting
 - 1 – 3/8 NPT Hex Socket Steel Pipe Plug
 - 1 – Installation Instructions, 300-133/300-134, IS# 199R10692
- 1 – 508-22 Gasket Set, Intake Manifold Mounting (which contains)
 - 8 – O-Rings, 3/32" Dia. Round Sect. Viton, Size 2-146, 2-5/8" I.D., Port Flg. Seals
- 1 – 300-218 Plenum Top Kit, Longitudinally End-Mounted 92mm LS 4-bolt Throttle Body (which includes)
 - 1 – Machined Plenum Top, 1x92mm Long.-End-Mount LS 4-bolt TB
 - 1 – Throttle Body Gasket LS 4-bolt, Holley Service P/N 508-20
- 1 – 300-231 Plenum Base Adapter Kit (which Includes)
 - 1 – Machined Plenum Base Adapter
 - 1 – Plenum Base Adapter Installation Kit labeled 85R9713 (which includes)
 - 12 – 1/4-20 UNC x 7/8" Long Socket Head Cap Screws, Zinc Plated, Plenum Attachment Bolts
 - 8 – 5/16-18 UNC x 1" Long Socket Head Cap Screws, Black-Oxide. Plenum Base Adapter Attachment Bolts
 - 4.5 ft – O-ring Cord, 3/32" Dia. Round Section Viton, Plenum Flange Seal, Holley Service P/N 508-21
 - 2 – Gaskets, Plenum Base Adapter to Intake Manifold, 0.020" Thick Flat
 - 1 – 1/4 NPT Hex Socket Steel Pipe Plug
 - 1 – 1/8 NPT Hex Socket Steel Pipe Plug
 - 1 – Installation Instructions 300-126/300-135/300-231, IS# 199R10612
 - 1 – Warranty Card
- 1 – Warranty Card

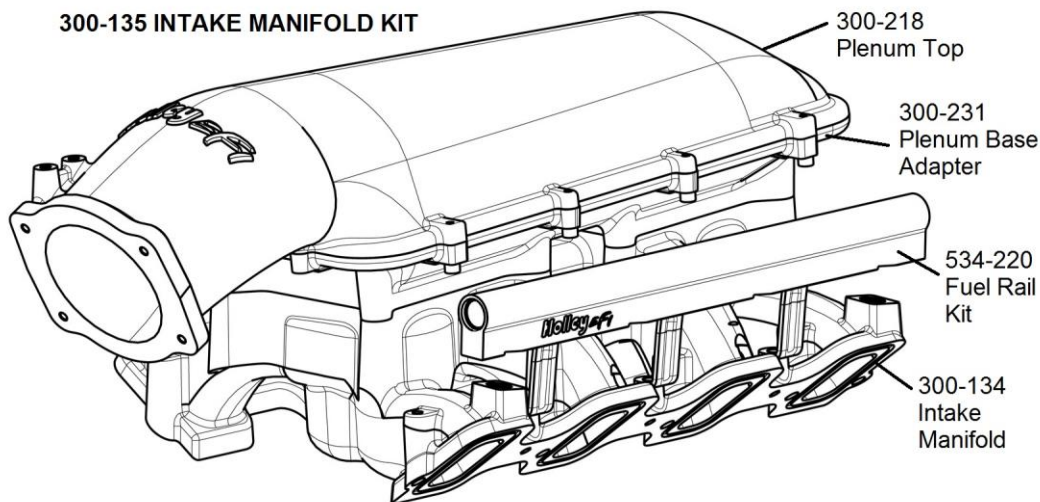

Figure 2

300-231 PLENUM BASE ADAPTER KIT CONTENTS:

- Machined Plenum Base Adapter
- Plenum Base Adapter Installation Kit labeled 85R9713 (which includes)
 - 12 – ¼-20 UNC x 7/8" Long Socket Head Cap Screws, Zinc Plated, Plenum Attachment Bolts
 - 8 – 5/16-18 UNC x 1" Long Socket Head Cap Screws, Black-Oxide. Plenum Base Adapter Attachment Bolts
 - 4.5 ft. – O-ring Cord, 3/32" Dia. Round Section Viton, Plenum Flange Seal, Holley Service P/N 508-21
 - 2 – Gaskets, Plenum Base Adapter to Intake Manifold, 0.020" Thick Flat
 - 1 – ¼ NPT Hex Socket Steel Pipe Plug
 - 1 – 1/8 NPT Hex Socket Steel Pipe Plug
 - 1 – Installation Instructions 300-126/300-135/300-231, IS# 199R10612
 - Warranty Card

300-231 PLENUM BASE ADAPTER

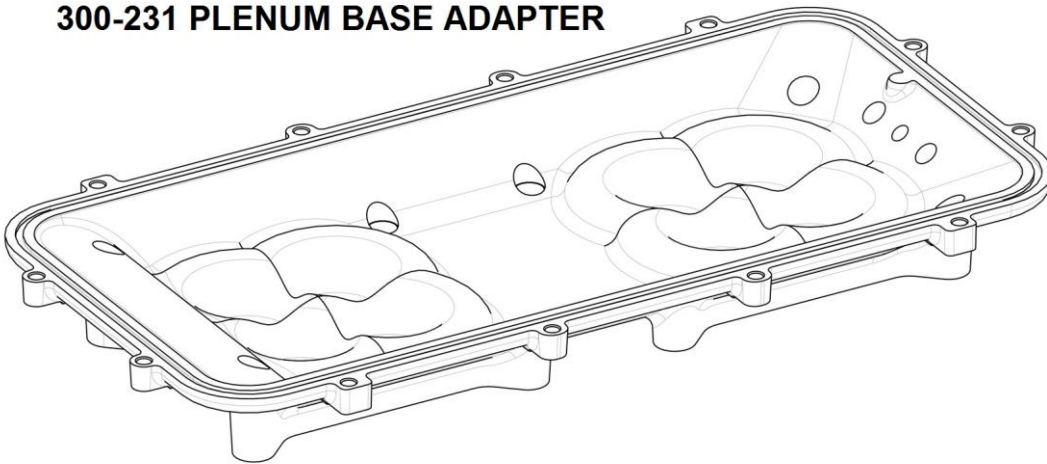

Figure 3

INSTALLATION INSTRUCTIONS:

Installation of the 300-121(300-126) or 300-134 (300-135) –

The first step for installing Mid-Rise intake manifold kit is to install the base dual-quad EFI intake manifold, 300-121 for the 300-126 kit or 300-134 for the 300-135 kit. Please consult the base intake manifold installation instructions, 199R10577 (300-121) or 199R10692 (300-134). Included are instructions for the installation of the intake manifold, fuel injectors, fuel rails, and fuel plumbing. It is recommended that the order of installation be: the intake manifold, the plenum base adapter, the plenum top, and then the fuel injectors-fuel rails-fuel plumbing.

Installation of the Plenum Base Adapter (Install of 300-126 or 300-135 Intake Manifold Kit) –

Once the LS dual-quad EFI intake manifold is installed on the engine:

1. Place the two flat plenum base-to-intake manifold gaskets from installation kit 85R9713 on the intake manifold carb flanges. Holley® recommends gluing each gasket to the intake manifold carb flanges in two places with gasket contact adhesive so the gaskets stay in proper position while installing the base plenum adapter.
2. Place the plenum base adapter in position. The vacuum ports should be towards the rear or opposite the end where the throttle body will be located. **Please Note: With the plenum base adapter installed on a 300-121 manifold (in 300-126 kit), the right front fuel rail mounting boss on the manifold will block the insertion of the adjacent plenum attachment socket head cap screw (5/16-18 x 1"). It will be helpful to insert the 1/4-20 x 7/8" cap screw into the plenum base adapter at this one location prior to the final installation of the plenum base adapter to the base intake manifold.**
3. Install the eight 5/16-18 x 1" long socket head cap screws. Apply motor oil to threads and under-head surfaces of the socket head cap screws and tighten the fasteners in two steps to 10 ft-lbs and then 15-18 ft-lbs using the tightening sequence shown in **Figure 4**. Continue tightening the fasteners in this pattern until the gaskets are compressed and none of the fasteners move at 15 -18 ft-lbs.

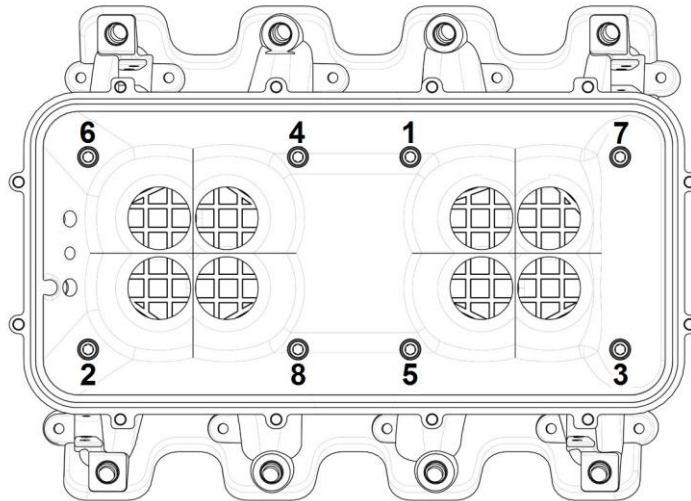

PLENUM BASE ADAPTER FASTENER TIGHTENING SEQUENCE

Figure 4

Installation of the Plenum Base Adapter (Custom Install of 300-231 on a Dual-Quad Intake Manifold) –

The 300-231 plenum base adapter kit can be used to adapt any Hi-Ram plenum top, or a custom fabricated plenum top using the Hi-Ram plenum flange pattern, to a dual-quad intake manifold with 4150 carb flanges that are on a 8-5/8" spacing for the purpose of creating a custom EFI intake manifold. There are several items that should be checked before installing the 300-231 plenum base adapter to your dual-quad intake manifold:

- ❑ Are there any interference issues with the 300-231 plenum base adapter as installed on your intake manifold in your vehicle? Does the plenum base adapter, the plenum top, the throttle body, and the air filter to throttle body ducting clear the chassis, hood, other engine components such as the distributor, rocker covers, breathers etc.?
- ❑ Do all of the intake manifold carb flange mounting bolt holes have a thread depth of at least 9/16 of an inch (10 thread turns minimum)? If there not 10 turns of thread depth in all of the carb flange mounting holes, the holes will need to tapped deeper with a 5/16-18 UNC bottoming tap so that there are ten thread turns of depth.
- ❑ The intake manifold carb flange charge-air openings should be at least 1-11/16 in diameter. If the carb flange charge-air opening diameters are less than 1-11/16", a step at the plenum base adapter mounting flange could hamper air-flow in the intake manifold and limit performance.

If none of the above issues are present for the 300-231 plenum base adapter in a custom installation, install the plenum base adapter on the intake manifold as it would be installed on the 300-121 or 300-134 intake manifold.

Installation of the Plenum Top –

1. Before installing the plenum top, the supplied o-ring cord will need to be cut to length and glued together.
2. Lay the o-ring cord into the groove on the plenum flange of the base manifold with the free end overlapped.
3. Mark the position of the cut to be made across both o-ring ends.
4. Lay the o-ring on a flat surface with the ends overlapped and the marks aligned as they were when the marks were made.
5. With a sharp razor blade cut thru both ends of the o-ring at the mark simultaneously.
6. With a drop of super glue, Cyanoacrylate, bond the ends of the o-ring together. The glued joint should be smooth, not offset or kinked.
7. To ensure sealing at the glued joint apply a thin film of silicone sealer around the o-ring at the glued joint, allowing the silicone to partially cure before installation of the o-ring in the groove.
8. Install the o-ring in the groove on the base manifold plenum flange. Place the plenum top in place.

9. The plenum top flange is symmetrical so the top will fit in either a forward or rearward orientation. For the EFI top with the LS throttle body flange, the throttle body flange could go to the front or the rear, as desired.
10. Apply a drop of engine oil to the thread and under-head of the supplied 1/4-20 x 7/8" long socket head cap screws. Insert the fasteners through the plenum base adapter plenum flange bosses from the underside and thread into the plenum top.
11. Gently tighten the fasteners evenly - starting from the middle of the sides, crossing side to side, and moving towards the ends until the plenum top is seated and the o-ring is compressed. Tighten the fasteners in two steps using the tightening pattern shown in **Figure 5**. Tighten to 75 in-lbs for the first step and 130 in-lbs for the second step.

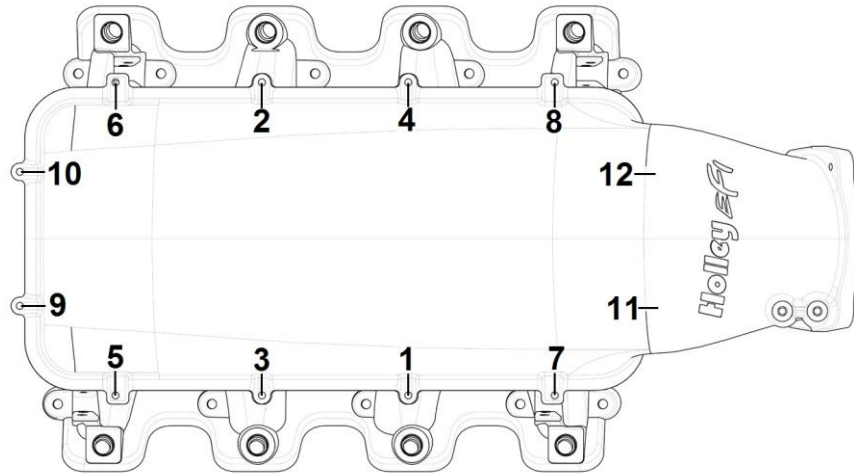

PLENUM TOP FASTENER TIGHTENING SEQUENCE

Figure 5

Installation of the Fuel Rails, Fuel Injectors, and Fuel Plumbing –

NOTE: The 300-121 intake manifold with the 534-204 fuel rail kit is designed to accept Bosch style EV-1 or Magneti Marelli Pico fuel injectors. OE LS fuel injectors may not fit properly in the EFI intake manifold and fuel rail assembly. There is a kit available separately to allow the use of stock LS7 fuel injectors, P/N 300-230 (see below in the service parts section). Some drilling and tapping of additional bolt holes on the fuel rail mounting bosses will be required for use of the 300-230 kit on a 300-121 manifold.

A fuel rail kit that is used with the 300-121 EFI intake manifold is included in the 300-126 Mid-Rise intake manifold kit. When installing the fuel rail kit, fuel injectors, and fuel plumbing, follow installation instructions (199R10577) given for the 300-121 intake manifold.

The 300-134 EFI intake manifold (in 300-135 kit) uses three brackets per side to mount each fuel rail to the manifold. As with the 300-126 the fuel rail kit is included. This fuel rail kit includes brackets that allow using either Bosch style EV1 or GM LS7 fuel injectors. Please consult the installation instructions (199R10692) from the 300-134 intake manifold installation kit for the installation of the fuel rail kit, fuel injectors, and fuel plumbing.

Installation of the Throttle Body and Air Filter to Throttle Body Ducting –

The 300-218 plenum top included with the 300-126 and 300-135 Mid-Rise EFI intake manifold kits is designed to be fitted with a 90mm 4-bolt (LS2 & later) drive-by-wire throttle body. Holley EFI's Dominator ECU will control drive-by-wire GM throttle bodies. For drive by cable applications Holley offers a 95mm cable actuated throttle body (with taper), P/N 112-585.

Included in the 300-218 plenum top is a flat composition throttle body gasket that can be used with throttle bodies from 90-102mm bore diameter. If using the gasket with a 102mm throttle body remove inner part of the gasket throttle bore cutting along the perforation in the gasket with a sharp knife or razor.

The throttle body flange on the 300-218 plenum top is sized at 92mm. If a larger throttle body, up to 105mm diameter, is desired, the throttle body flange and entry duct of the plenum top can be ported up to 105mm. A plenum top machined for up to a 105mm throttle body is also available, P/N 300-219. Drive by cable 105mm Holley throttle bodies, P/N 112-581 (with taper) and P/N 112-583 (straight bore) are also available. A gasket for a 105mm throttle body is supplied with either 105mm throttle body.

The configuration and placement of the air filter and the air filter to throttle body ducting can significantly impact engine performance. Pick an air filter with adequate flow capacity and choose a location for the air filter where fresh air of ambient temperature will be ingested. It is not desirable for the engine to ingest hot air coming from the radiator or from over the exhaust headers. The number of bends in the ducting should be minimized and the radius of the bends should be as large as possible. Air filter locations where water could be ingested off the road should be absolutely avoided.

Installation of the MAP Sensors and Use of Vacuum Ports –

For both the 300-126 and 300-135 Mid-Rise EFI intake manifold kits, there is a port on the back of the plenum base adapter for a GM LS3 style MAP sensor (O-ring seal on the nipple and retained with a single ¼-20 UNC bolt). Also, on the back of the plenum base adapter, there is a 1/8 NPT vacuum port and a ¼ NPT vacuum port. On the back of the 300-121 or 300-134 intake is a 3/8 NPT vacuum port.

For a 300-126 or 300-135 installation, It is recommend to route the brake booster vacuum hose to the 3/8 NPT port on the back of the 300-121 or 300-134 intake manifold. For the installation of a 300-231 on a dual-quad intake manifold it would also be preferable to route the brake booster hose to a port on the intake manifold that is 3/8 NPT or larger.

PCV routing should be connected to a PCV hose nipple on the throttle body if available (consult the installation instructions for the throttle body). If there is no PCV connection on the throttle body use the 1/4 NPT port on the plenum base adapter. The 1/8 and 1/4 NPT ports on the plenum base adapter are available for other vacuum signal supply requirements. Hex socket NPT pipe plugs are supplied in the installation kits to plug any of the vacuum ports that are not being used.

NOTE: Holley EFI LS main harnesses have a map sensor connector designed for use with an LS1/2 style map sensor. The 558-416 is an adapter harness that can be used to adapt any LS harness that uses a LS1/2 MAP sensor connection to a LS3 MAP, which is recommended for this manifold.

MAP Sensor Information - LS3 MAP sensor, GM P/N 12591290, will cover naturally aspirated (1 bar) applications; a LS9 MAP sensor (post blower), GM P/N 12592525 (red label) should cover forced induction applications up to 3 Bar. The LS3 MAP sensor does not have the same absolute pressure measurement to voltage output range as a LS1 or LS2 MAP sensor. An ECU set up for the manifold absolute pressure to voltage output of the LS1 or LS2 MAP sensor will need to be recalibrated to properly operate the engine with the LS3 MAP sensor. The LS3 MAP sensor plug is also different than the LS1/LS2 MAP sensor. Pigtail adapters are available. Consult the ECU manufacturer or tuner for the proper ECU MAP sensor calibration for the MAP sensor that you plan to use.

If the use of an LS3 style GM bolt-on MAP sensor is not desired, the MAP port on the plenum base adapter can be tapped 1/4 NPT, and a fitting used in the port to plumb a hose to a MAP sensor mounted at some other location. The LS1 or LS2 MAP sensor can be mounted with a simple hand-made sheet metal bracket and a hose connected to the nipple that is on the MAP sensor with the grommet seal removed.

HI-RAM PLENUM TOPS AND SERVICE PARTS AVAILABLE SEPARATELY:

Plenum Tops

300-216 – 2 x 4150 Carb/Throttle Body Plenum Top (best performance configuration with two 112-577 throttle bodies)
300-217 – Blank Flange Configurable Top (could be used to fabricate a custom plenum top configuration)
300-218 – 1 x 92mm LS Throttle Body, Longitudinal Mount
300-219 – 1 x 105mm LS Throttle Body, Longitudinal Mount

Fuel Rail Kits

534-204 – LS1/2/6 Hi-Ram Fuel Rail Kit, High Volume, 3/4-16 O-ring Port (AN-8) Connection
534-220 – Fuel Rail Kit for 300-134 LS3 Dual-Quad EFI intake Manifold
534-206 – Fuel Rail Extrusion, Raw, 12" Long, High Volume
534-207 – Fuel Rail Extrusion, Raw, 18" Long, High Volume
534-208 – Fuel Rail Extrusion, Raw, 36" Long, High Volume

Fabrication Flanges (for the fabrication of custom plenum tops)

300-220 – Hi-Ram Plenum Fabrication Flange, 0.50" Billet Machined Aluminum Plate
300-221 – Hi-Ram 92mm LS Throttle Body Fabrication Flange, 0.50" Billet Machined Aluminum Plate
300-222 – Hi-Ram 102mm LS Throttle Body Fabrication Flange, 0.50" Billet Machined Aluminum Plate

Service Parts

508-20 – Throttle Body Gasket, 92mm or 102mm LS Throttle Body
508-21 – Hi-Ram Plenum O-Ring Cord, 3/32" Round, Viton, 4.5' Long
508-22 – LS3 Hi-Ram Port Flange O-Rings, 3/32" Round, Size 2-146, 2-5/8" I.D., Viton, set of 8
508-23 – LS1/2/6 Hi-Ram Port Flange O-Rings, 3/32" Round, Size 2-151, 3" I.D., Viton, set of 8
534-104 – Fuel Injector O-Rings, Set of 16, O-ring supplied in fuel rail kit **534-220** to adapt LS7 injectors
300-230 – Fuel Rail Mount Adapter Kit, for using GM LS7 Injectors on the LS7 Hi-Ram

NOTE: The 300-230 adapter kit can also be used on the LS1 300-121 intake manifold. Drilling and tapping more bolt holes on the fuel rail mounting bosses is required; consult the 300-230 installation instructions for specifics.

Holley Technical Support
1801 Russellville Road
Bowling Green, KY 42101
1-866-464-6553
270-781-9741
www.holley.com

© 2013 Holley Performance Products, Inc. All rights reserved.

199R10612

Revision Date: 5-11-15