



PERFORMANCE EXHAUST SYSTEMS

# INSTRUCTION MANUAL

## SUPER TRUCK EXHAUST SYSTEM

### 99-05 CHEVY SILVERADO/SIERRA TRUCK

#### 4.3L, 4.8L, 5.3L 2/4WD

#### STANDARD CAB, SHORT BED

#### PART # 5516

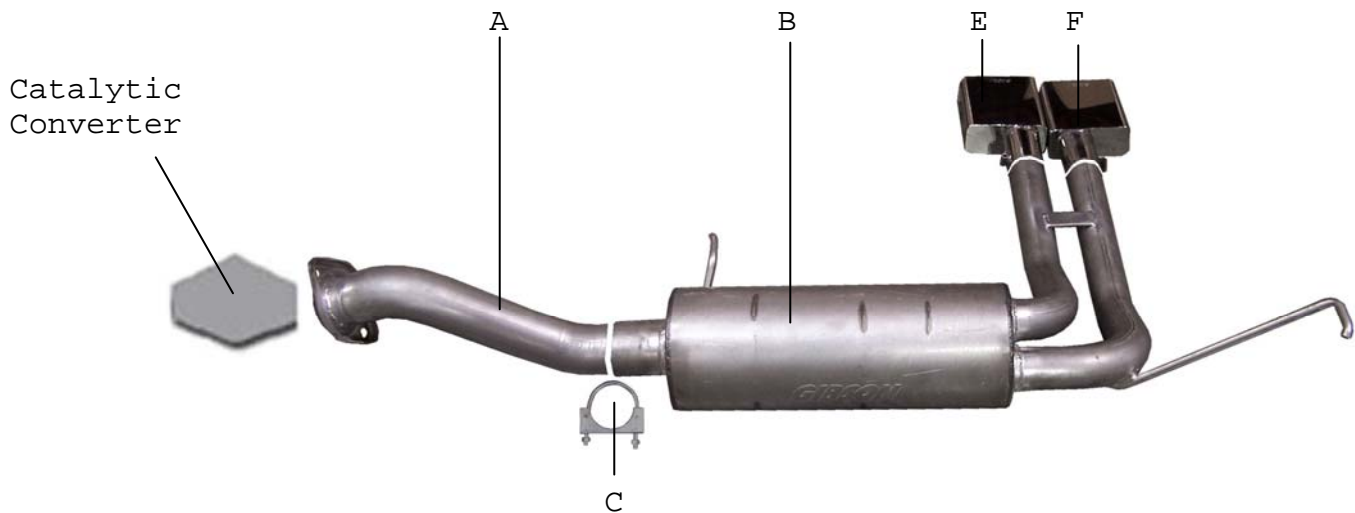

ITEM	PART #	QUANTITY	DESCRIPTION
A	700208	1	HEADPIPE WITH FLANGE#GP-115
B	700207	1	MUFFLER ASSEMBLY
C	OHD300	1	3" CLAMP
E	500365	1	SPORT TRUCK TIP
F	500366	1	SPORT TRUCK TIP

Thank you very much for purchasing our GIBSON PERFORMANCE EXHAUST SYSTEM for your vehicle. If you need further assistance, please do not hesitate to call our Technical Department at (800) 528-3044, Monday through Friday, 8:00 am to 5:00 pm.0505

# INSTALLATION INSTRUCTIONS #5516

WHEN INSTALLING THIS EXHAUST SYSTEM, MAKE SURE TO USE PROPER SAFETY PRECAUTIONS. USE JACK STANDS WHEN UNDER THE TRUCK, SET PARKING BRAKE, BLOCK TIRES, AND USE SAFETY GLASSES AND GLOVES. DO NOT WORK ON HOT PIPES!

## SUGGESTED TOOLS:

15MM SOCKET, 9/16" SOCKET, 1/2" WRENCH, JACK STAND, HACKSAW



LAY OUT THE GIBSON EXHAUST ON THE FLOOR SO IT LOOKS LIKE THE DRAWING AND COMPARE PART #'S WITH MANUAL. TO REMOVE YOUR STOCK EXHAUST, REMOVE IT FROM THE STOCK 2-BOLT FLANGE LOCATED JUST BEHIND THE CONVERTER, LEAVING ALL RUBBER GROMMETS IN PLACE. USE WD-40 TO AID YOU IN REMOVAL OF EXHAUST AND HANGERS. **DO NOT THROW AWAY FACTORY HARDWARE. YOU WILL RE-USE IT.**



INSTALL MUFFLER ASSEMBLY #B ONTO HEADPIPE #A. SLIDE WELDED HANGERS INTO RUBBER GROMMETS. USE CLAMP #C TO SECURE MUFFLER ASSEMBLY TO HEADPIPE. **DO NOT TIGHTEN.**



INSTALL HEADPIPE #A ONTO YOUR EXISTING STOCK 2-BOLT FLANGE. USE YOUR STOCK HARDWARE TO SECURE. **DO NOT TIGHTEN.** USE A JACK STAND TO SUPPORT THE CONVERTER.

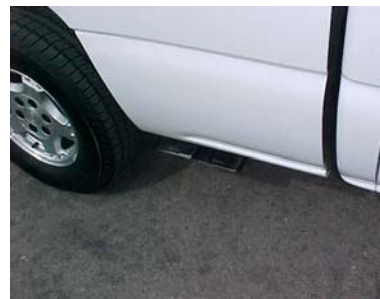

INSTALL YOUR STAINLESS TIPS, NOW TIGHTEN ALL NUTS, BOLTS, AND CLAMPS. TO CLEAN YOUR STAINLESS TIPS USE A SCOTT BRITE PAD AND ANY STAINLESS STEEL OR ALUMINUM CLEANER.

**MAKE SURE YOU HAVE AT LEAST A 1" CLEARANCE ON ALL PIPES FROM ALL RUBBER BRAKE LINES, FUEL LINES, SHOCK BOOTS, TIRES, ETC.**