



PERFORMANCE EXHAUST SYSTEMS

INSTRUCTION MANUAL

CAT-BACK SINGLE EXHAUST

95-97 FORD RANGER/MAZADA TRUCK 2.3L 2WD

STANDARD CAB, LONG BED

PART #19716

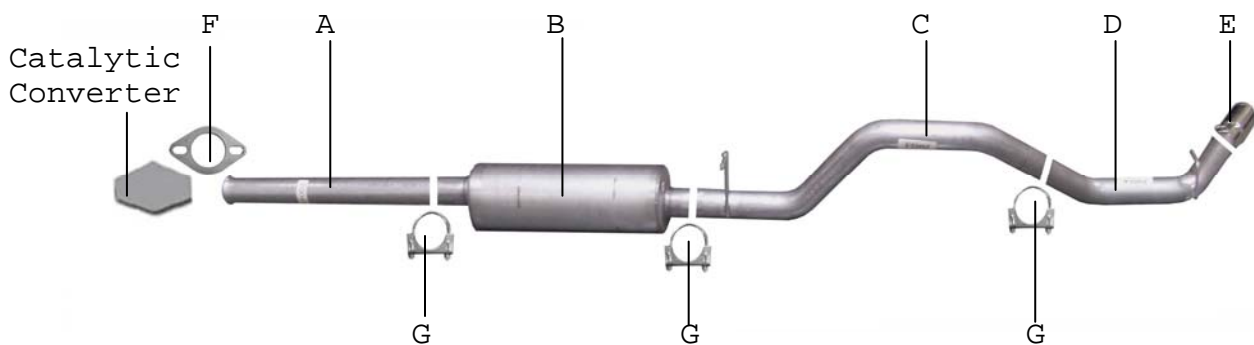

ITEM	PART #	QUANTITY	DESCRIPTION
A	700454	1	2 1/2" HEADPIPE
B	788200	1	SUPERFLOW MUFFLER
C	25002-5	1	2 1/2" OVERAXLE TAILPIPE
D	25002-A	1	2 1/2" TURNOUT PIPE
E	500361	1	3" STAINLESS TIP
F	GP-102	1	FLANGE
	BO-1034	1	BOLT KIT FOR FLANGE GP-102
G	5757	3	2 1/2" CLAMP

Thank you for purchasing our GIBSON EXHAUST SYSTEM for your vehicle. If you need any further assistance, please do not hesitate to call our Technical Department at 1-800-528-3044 Monday through Friday, 8:00 AM to 5:00 PM. 0903

EXHAUST INSTALLATION #19716

When installing this exhaust system make sure to use proper safety precautions. Use jack stands when under the truck, set parking brake, block tires and use safety glasses and gloves.

DO NOT WORK WITH HOT PIPES!

SUGGESTED TOOLS:

1/2" , 9/16", 15mm Socket & Wrench, WD-40, Jack Stand, Hacksaw



Lay out the exhaust on the floor so it looks like the drawing and compare parts with manual. To remove the stock exhaust Cut tailpipe behind muffler. Then unbolt the stock exhaust at the flange. Leave all rubber grommets in place. Use WD-40 to aid in removal of exhaust and hangers.



Install the over axle tailpipe #C into the muffler 1-1/2" to 2". Secure to the muffler using clamp #G. Do not tighten. Insert welded hanger into rubber grommet.



Install head pipe #A into flange #F. Bolt the flange and headpipe to the stock flange. Do not tighten.



Install the exit pipe #D on to the tailpipe. Insert welded hanger into rubber grommet. Secure together with clamp #G. Do not tighten. Roll the exitpipe until it is at the correct angle for your truck.



Install muffler onto head pipe 1-1/2" to 2" with the louvers facing towards the converter. Use a jack stand to support the muffler. Use clamp #G to secure the muffler to the head pipe. Do not tighten. Muffler inlet is looking into the louvers.



Install stainless steel tip. Clamp down. When you have everything in place, firmly tighten all bolts and clamp down securely. To clean stainless steel tip use any stainless steel cleaner and Scotch Brite pad.

MAKE SURE YOU HAVE A 1" CLEARANCE ON ALL RUBBER BRAKE LINES, SHOCK BOOTS, TIRES, FUEL LINES, ETC..

