

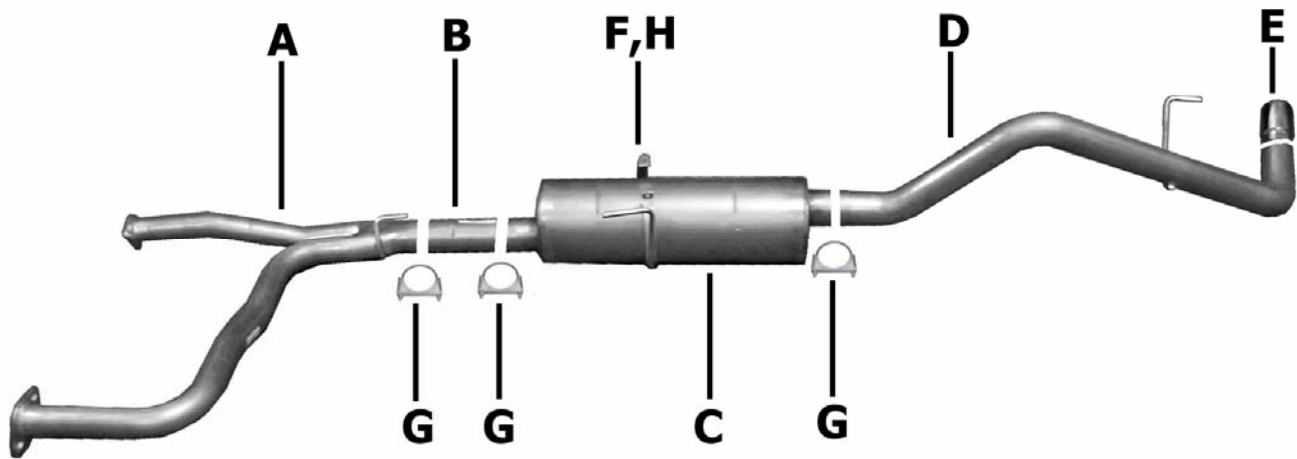

# Installation Instructions

Cat-Back Single Exhaust  
2007 Nissan Frontier 4.0L 2/4wd  
Crew Cab, Long Bed (6.1')

Part #12218



| ITEM | PART    | QUANTITY | DESCRIPTION                   |
|------|---------|----------|-------------------------------|
| A    | 700639  | 1        | 2.5" Y Pipe w/ GP-110 Flanges |
| B    | 700551  | 1        | 3" Resonator                  |
| C    | 788824  | 1        | Superflow SFT Muffler         |
| D    | 700640  | 1        | 3" Over Axle Tailpipe         |
| E    | 500360  | 1        | 3.5" Stainless Tip            |
| F    | 4237    | 1        | Band Clamp                    |
| G    | OHD300  | 3        | 3" Clamp                      |
| H    | BO-1015 | 1        | Bolt Kit for Band Clamp       |

Thank you for purchasing our Gibson Exhaust System for your vehicle.  
If you need further assistance, please do not hesitate to call our technical department at  
(800) 528 -3044 Monday through Friday, 8am to 5 pm.

# Installation Instructions #12218

When installing this exhaust system make sure to use proper safety precautions. Use jack stands when working under the vehicle, set parking brake, block tires and use safety glasses and gloves. Allow exhaust to cool before attempting installation. Severe injury or burns could occur if safety measures are not taken.

**SUGGESTED TOOLS:** 1/2", 9/16", 12 & 14mm wrenches & sockets, WD-40, hacksaw, jack stands

1. Disconnect the negative battery cable before removal of OEM exhaust. This will allow the computer to reset and recognize the new exhaust. Lay out the exhaust on the floor so it looks like the drawing and compare parts with manual.



2. To remove your stock tailpipe, remove the clamp shown here. Disengage hanger from rubber grommet. Use WD-40 to aid in this process. Leave all rubber grommets on the factory hangers on the vehicle.



6. Slide muffler #C onto the resonator 1.5-2". Use clamp #G to secure muffler to resonator. Do not tighten. Outlet will be at the 12 o'clock position. Inlet of muffler will be looking into the louvers.



3. Next, unbolt the 2-bolt flanges located just behind the factory converters. Do not discard the factory gaskets and hardware. You will reuse these items when installing the Gibson system.



7. Install band clamp #F onto muffler. Insert hanger into rubber grommet. Use provided bolt kit #H. Do not tighten.



4. Install Y Pipe #A onto the stock flanges using the stock gaskets and hardware. Do not tighten. Insert welded hanger into rubber grommet.



8. Slide over axle tailpipe #D into muffler 1.5-2". Insert welded hanger into rubber grommet. Use clamp #G to secure tailpipe to muffler.



5. Slide resonator #B onto the Y Pipe 1 1/2"-2". Use clamp #G to secure pipes together. Do not tighten.



9. Install stainless steel tip. Clamp down. When you have everything in place, firmly tighten all bolts and clamps down securely. Use stainless steel cleaner and a Scotch Brite pad weekly to prevent tip from discoloration. Inspect all fasteners after 25-50 miles of operation and re-tighten as necessary.

GIBSON EXHAUST systems are designed on a factory stock vehicle. Any aftermarket products installed could increase the sound levels of the exhaust. **Make sure there is a 1" clearance from ALL rubber brake lines, shock boots, lines, tires, etc. to prevent heat related damage or fire.**