

OWNER'S MANUAL



Hitch ball not included.

Model	Max Tongue Weight (lb)	Max Trailer Weight (lb)
92-00-0450	450	4,500

Read the entire manual before starting installation.

Dealer: Please give this manual to the end user after hitch installation.

Your model # can be found on the stickers on either spring bar.

Fastway e2 Hitch - Faster, Easier.TM

Parts Breakdown

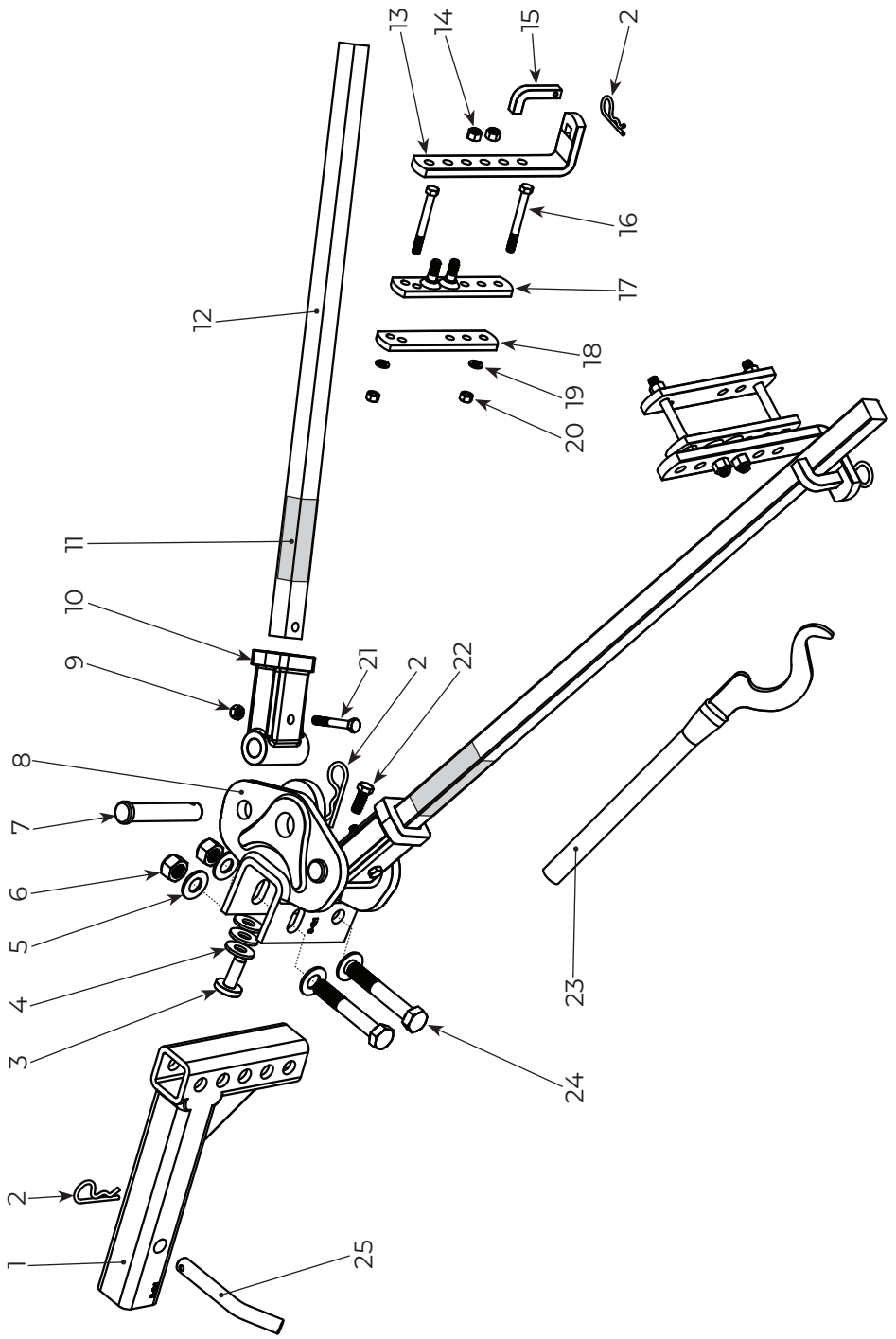

Item #	Part Number	Part Description	Qty.
1	92-02-4116	Adjustable shank	1
2	92-04-9705	Cotter pin / R-clip	5
3	92-04-9650	Spacer rivet	1
4	92-04-9655	1/2" spacer washer	3
5	92-04-9726	5/8" flat washer	4
6	92-04-9736	M16-2 nylock nut (class 8) zinc	2
7	92-04-9743	3/4" X 4" clevis pin	2
8	92-02-0426	Hitch head	1
9†	92-04-9766	M8-1,25 nylock nut (class 8) zinc	2
10†	92-02-0456	4.5K trunnion knuckle	2
11†	--	Spring bar sticker	2
12†	92-02-0496	4,500 lb spring bar (single)	2
13	92-02-5140	L-bracket	2
14	92-03-9486	7/16"-14 nylock nut (grade 5)	4
15	92-03-9460	L-pin	2

Item #	Part Number	Part Description	Qty.
16	92-03-9470	3/8"-16 X 3-1/2" hex bolt (grade 5)	4
17	92-02-5354	Outside link plate	2
18	92-02-5240	Inside link plate	2
19	92-03-9490	3/8" split washer	4
20	92-03-9475	3/8"-16 nut (grade 5)	4
21†	92-04-9756	M8-1,25 x 55 HCS (Class 8.8) zinc	2
22	92-03-9746	3/8"-24 X 1" HCS (grade 5) zinc	1
23	92-02-6040	Snap-up lever	1
24	92-04-9786	M16-2 X 100 HCS (class 8.8) zinc	2
25	92-04-9625	Hitch pin	1
NS	BD091	e2 4.5K trunnion owner's manual	1

† Comes preassembled as one unit
NS Not Shown

Table of Contents

	Page
Parts Breakdown	2-3
Important Safety Information	5
Important Hitch Information	7
Important Setup Information	7
Step 1: Ready the Tow Vehicle and Trailer	8
Step 2: Install the Hitch Ball	8
Step 3: Attach Hitch Head to Shank	9
Step 4: Sway Control Bracket Assembly	11
Step 5: Spring Bar Installation	14
Step 6: Weight Distribution Setup	15
Step 7: Weight Distribution Adjustment	17
Step 8: Trailer Pitch Adjustment	20
Step 9: Final Tightening	20
Step 10: Regular Maintenance	21
Step 11: Hitching Up	22
Step 12: Unhitching	23
Appendix A: Troubleshooting Guide	25
Customer Support	26
Appendix B: Weight Distribution Adjustments	27
Appendix C: Installing With Auto-Level/Air Bags	28
Warranty	29
Service Tech Checklist	30

Tools Needed For Hitch Installation

- (2) 15/16" or 24mm socket or wrench (shank bolts)
- (2) 9/16" socket or wrench (link plate and angle set bolts)
- (1) 5/8" socket or wrench (L-brackets)
- (1) Torque wrench capable of 130 ft-lb of torque (shank bolts)
- Measuring tape
- Pencil

Recommended Tools For Installing The Hitch Ball

- (1) 1-1/2" socket
- (1) Socket extension
- (1) Torque wrench capable of reaching torque recommended by hitch ball manufacturer, approximately 250 ft-lb

Warning Stickers

ATTENTION

Changes in tow vehicle & trailer loading can change weight distribution requirements and vehicle handling.

For best performance check your hitch setup often. Verify that proper weight distribution is achieved. Refer to owner's manual.

e2TN_1012

Head Sticker



Bar Sticker
(not actual size)

Important Safety Information

Failure to follow all safety warnings may result in severe injury or death.

⚠ WARNING

Read, understand, and follow all safety warnings, setup, use, and maintenance instructions of your trailer, tow vehicle, and hitching equipment before installing your hitch or towing your trailer.

Never cut, weld, grind, bend, or modify hitch components in any way.

It is the driver's responsibility to adjust equipment and driving habits to match towing conditions. The driver is responsible for their own safety and the safety of passengers.

Never exceed the specified weight ratings for the trailer, tow vehicle, hitch, hitch ball, or any other towing equipment.

No hitch setup guarantees that trailer sway will be altogether avoided.

Always load trailer correctly. Follow trailer and tow vehicle manufacturer's recommendations for placement and quantity of cargo.

Towing with a tongue weight more than 15% or less than 10% of gross trailer weight greatly increases the likelihood for loss of vehicle control.

Always use a hitch ball with a rating that equals or exceeds the trailer Gross Vehicle Weight (GVW). Always use a hitch ball size that correctly matches your trailer coupler size and make sure it is coupled securely before towing.

Measuring weight distribution setup well does not ensure safe towing. The operator is responsible for making necessary adjustments to the hitch to optimize weight distribution and sway control. Each trip is different, and the weight distribution setup and towing performance should be evaluated by the operator and adjusted when necessary.

Never tow with your hitch adjusted incorrectly.

Check all hardware before each trip. Do not tow your trailer until all bolts and nuts have been checked for wear and fatigue, are properly tightened, and all pins and clips are securely in place.

Do not tow with your hitch engaged on rough roads, through profound ditches, dips, or swales, or while launching a boat if you need more rear wheel traction. Excessive strain on the spring bars and hitch head may cause hitch fatigue or failure.

If your dealer installed your hitch, verify that it is still adjusted correctly after loading your trailer and tow vehicle for your trip.

Replace worn, faded, or unreadable warning stickers on the hitch.

Do not transfer hitch to a different tow vehicle or trailer without adjusting the hitch for proper setup and weight distribution.

CAUTION

Do not loosen or remove any part of the hitch while the hitch is under load. Use the tongue jack to take the tension off the weight distribution bars before removing the L-pins.

Always secure the tow vehicle and trailer with the parking brake and wheel chocks before setting up or adjusting the hitch.

Disengage weight distribution before towing or backing the trailer where there is a significant transition in grade which puts excessive strain on the hitch, e.g. backing from a flat street to a steep uphill driveway.

Important Hitch Information

Weight Distribution

Weight distribution is the ability of a hitch to transfer load from the rear axle of the tow vehicle to the front axle of the tow vehicle and to the trailer axles. Without weight distribution the tow vehicle teeter-totters on the rear axle of the tow vehicle, and unloads the front axle. Proper weight distribution transfers weight back to the front axle, forcing it back to the ground.

Proper weight distribution also adds performance to the built-in sway control feature of your e2 hitch. As the trailer's tongue weight gets distributed, it helps generate the friction needed to defend against trailer sway.

Sway Control

Sway control is a built-in, patent pending feature of your e2 hitch. Unlike old chain style weight distribution hitches, which do not provide sway control, you do not need to purchase, install, store, or hook up any additional hardware to get sway control. You can back up without disengaging the hitch. Once the spring bars are tensioned, the sway control is in force.

Built-in sway control on the e2 hitch works through the connection between your weight distribution bars and L-brackets. The force required by the hitch to distribute weight rests on the L-brackets through the spring bars. The e2 hitch takes advantage of the steel-on-steel friction generated at these points to defend against trailer sway.

This added friction makes it difficult for the trailer to sway side-to-side while it's being towed, as sometimes happens when you encounter a gust of wind or pass a semi-truck. When set up correctly and properly adjusted for your load, the e2 hitch will noticeably reduce sway.

Important Setup Information

Every trailer and tow vehicle combination requires a different setup and adjustment because of factors like trailer weight and length, trailer loading, hitch weight, and tow vehicle geometry and suspension. It is not likely that a good setup for one vehicle combination will work well for another. **If you change the tow vehicle and/or trailer, you should change the hitch setup for proper weight distribution and adjust it when necessary.**

You must use your best judgment to determine if changes to the setup are required to ensure a safe and comfortable towing situation. There is no all-inclusive formula for setting up or adjusting a hitch that will accommodate each combination of trailer and tow vehicle possible.

The setup may need to be changed slightly at times to accommodate changes in your trailer load, perhaps even during the same trip. For example, a trailer that

starts with full clean water and propane tanks may tow differently when that water becomes black and grey water, and the propane tanks are empty. Or, a trailer loaded with gear for a long cross-country trip may tow differently than the same trailer loaded for a weekend getaway. The driver must be conscious of these changes, and adjust the hitch accordingly.

Step 1 - Ready the Tow Vehicle and Trailer

Check and inflate the tires on both the tow vehicle and trailer to their proper pressures before setting up the hitch.

Park the trailer and tow vehicle on level ground and in line with each other. Chock and uncouple the trailer. Pull the tow vehicle forward to allow about five feet of working area in front of the trailer, and set the parking brake.

Ideally, when installing or adjusting the hitch, the tow vehicle and trailer should be loaded just as they will be while traveling. This includes full propane and fresh water tanks, and any other cargo (passengers & gear) the tow vehicle or trailer will carry, including ATVs for toy haulers. If fully-loaded is not possible, set the hitch up for the trailer as-is, and make adjustments later if needed.

If your tow vehicle is equipped with an auto-leveling suspension, or suspension air bags, carefully read and follow the instructions in Appendix C - Installing With Auto-Level/Air Bags on p. 28 as you set up and use your hitch. Also review your tow vehicle owner's manual for specific information about using your auto-leveling system while towing.

Step 2 - Install the Hitch Ball

WARNING

Never exceed the specified weight ratings for the trailer, tow vehicle, hitch, hitch ball, or any other towing equipment.

Install a properly-sized hitch ball onto the hitch head. The hitch ball diameter must match the trailer coupler size.

Select a ball with a 1" diameter threaded shank. Make sure the hitch ball has a weight rating equal to or greater than your trailer's gross vehicle weight (GVW). Always use a lock washer against the nut, unless otherwise specified by ball manufacturer. Torque the nut to the ball manufacturer's specifications.

Hitch balls require a 1-1/2" socket and a torque wrench capable of approximately 250 ft-lb torque for installation. Your nearest Fastway e2 hitch dealership will have the tools needed and will usually install the hitch ball for a reasonable fee.

Step 3 - Attach Hitch Head to Shank

Level the Trailer

Measure from the ground at the front and back of the trailer frame, and adjust the trailer to be parallel to the ground (both front and back measurements should be the same).

With the trailer parallel to the ground, measure to the top of the trailer coupler. The top of the hitch ball should be initially placed between 0" and 1" above this height. See Figure 1.

Attach Head to Shank

Insert the adjustable shank into the receiver on the tow vehicle and secure it with the hitch pin and clip.

Insert the spacer rivet with the spacer washers into the back of the hitch head to set the angle of the hitch head. See Figure 2. Start most setups with 2 spacer washers. If your actual tongue weight is greater than 350 lb, start with 3 spacer washers. Some setups with lighter tongue weight may only need 1 spacer washer.

Slide the bolt channel around the shank and hold the hitch head so that the top of the hitch ball is located between 0" and 1" above the coupler height.

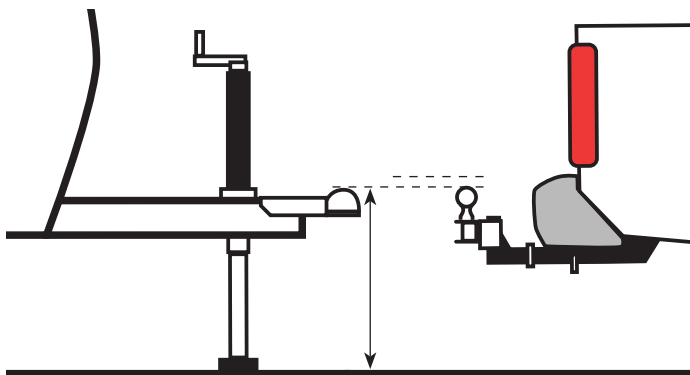

Figure 1 - Set the top of the hitch ball height between 0" and 1" above the top of the coupler height, with the trailer parallel to the ground.

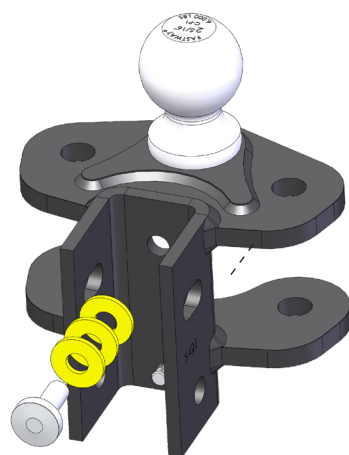

Figure 2

In some cases, the shank may need to be turned upward, or a specialty length shank may be needed so that the ball can be placed at the correct height. See Figure 3.

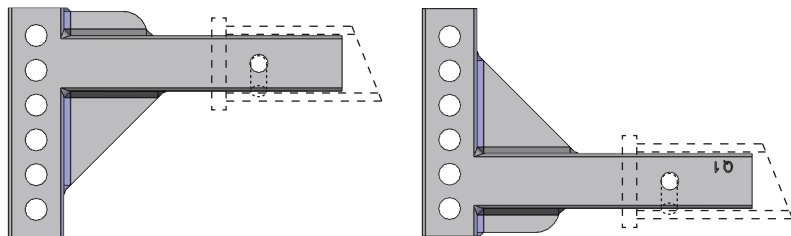

Figure 3

Insert a 16mm shank bolt with a 5/8" flat washer through the bottom hole in the bolt channel and corresponding shank hole to hold the head at the correct height. Slide another washer, then a 16mm nut onto the other side of the bolt, and hand-tighten them. Repeat this process for the top shank bolt. See Figure 4.

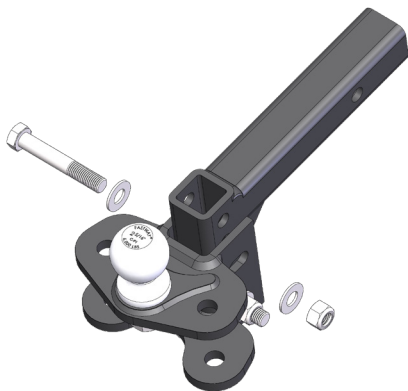

Figure 4

Use a wrench to tighten the angle set bolt until it comes into contact with the shank and lifts the head to where the spacer rivet also comes into solid contact with the shank. Tighten the angle set bolt an additional 1/2 turn. The hitch head should be angled down slightly. See Figure 5.

The shank bolts will be fully tightened at the end of the set up and adjustment process.

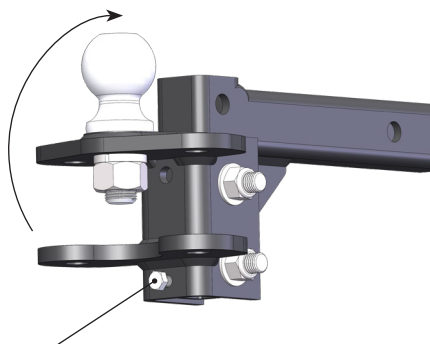

Figure 5

Step 4 - Sway Control Bracket Assembly

Sway Bracket Location

Measure from the center of the coupler along the trailer frame, and place a mark at 30" on both sides. This is the center mark for the sway control bracket assembly.

Make sure there are no gas lines, brake lines, or electrical wires located along the frame that could be affected by the installation of the link plates. If so, re-route or avoid the lines so their function will not be disrupted or damaged by the link plate installation.

Placing the sway control brackets centered at 30" back puts the least amount of stress on the trailer and hitch components, and provides the most comfortable ride. Sway brackets should be placed at 30" whenever possible.

In some cases where there is an obstruction at 30" that cannot be avoided, like a battery rail or propane tank support, the brackets may be moved forward up to a minimum distance of 25" from the center of the coupler. See Figure 6.

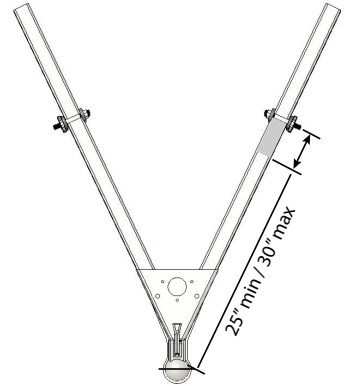

Figure 6

Assemble Link Plates

Insert one $\frac{3}{8}$ " x $3\text{-}1/2$ " bolt through the single hole of the outside link plate so it goes through in the opposite direction of the L-bracket mounting studs. Insert the same bolt through the corresponding hole on the inside link plate.

Slide on a split washer, and then thread on a $\frac{3}{8}$ " nut a few turns. See Figure 7.

Choose the correct set of holes to use to keep the bolts tight to the frame based on your frame height. See Figure 8.

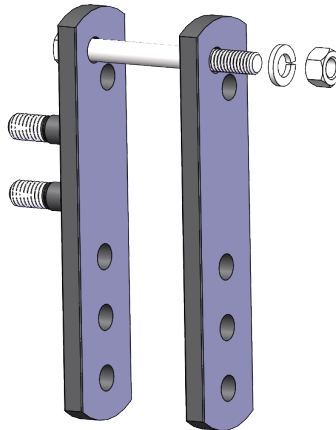

Figure 7

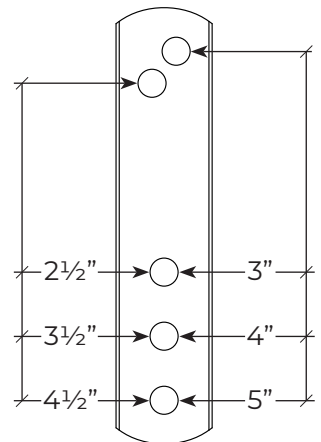

Figure 8 - Bolt placement for frame size

Identify your coupler style.
See Figure 9.

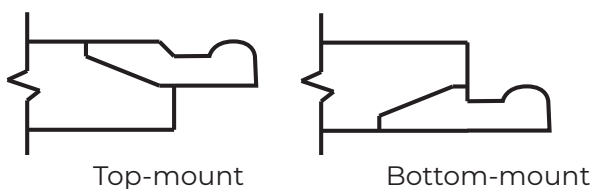

Figure 9

Top-mount Couplers

Place the link plates so the single offset holes are above the trailer frame, and the L-bracket studs are toward the top of the frame on the outside. See Figure 10.

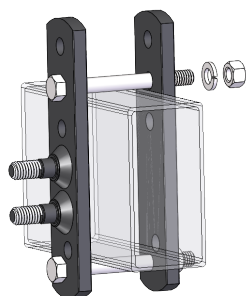

Figure 11

Bottom-mount Couplers

If your trailer has a bottom-mounted coupler, is a V-nose trailer, or has some other obstacle that makes installing the link plates in the upright position difficult, install the link plates upside down so that the single offset holes are below the trailer frame, and the L-bracket studs are toward the bottom of the frame. See Figure 11.

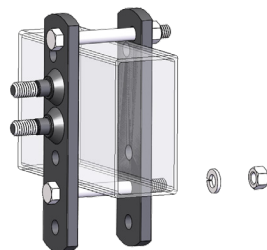

Figure 10

Insert the second bolt through the link plates from the outside in and tight against the frame. Slide on a split washer, then thread a 3/8" nut onto the bolt.

There should not be a gap between the trailer frame and the link plate bolts above or below the frame. See Figure 12. Move electrical or propane lines if necessary.

	Correct - No Gaps	Incorrect - Gap Between Frame and Bolt
Top-mount coupler or coupler		
Bottom-mount coupler or V-nose trailer		

Figure 12

CAUTION

Do not use an impact wrench to tighten the link plate or L-bracket bolts.

Pinch the link plates tight to the trailer frame so both lay flat against the frame, and hand-tighten the nuts on the inside. See Figure 13.

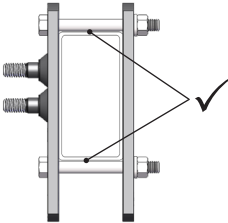
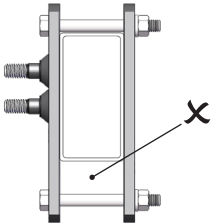
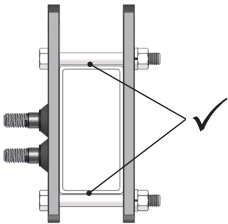
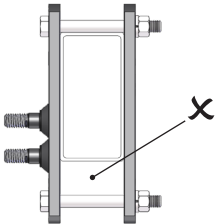
Tightening only one nut without first pinching the link plates to the frame may cause the inside link plate to bend when torqued completely. It may also give you a torque wrench reading that indicates the link plates are tight, even though they are not. See Figure 14.

Use wrenches to finish tightening the link plate bolts until they are snug, alternating from top to bottom bolt, 1/2 turn at a time. The link plate bolts should be torqued to 27 ft-lb.

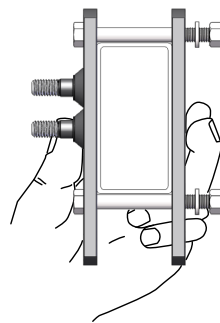

Figure 13
Correct

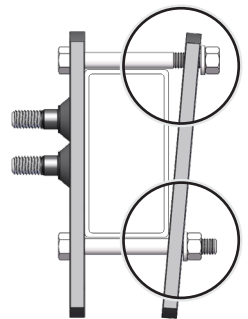

Figure 14
Incorrect

L-bracket Installation

For the first setup, slide the L-brackets onto the link plate studs with the studs in the two center holes, with the friction plate facing away from the trailer. They may need to be adjusted up or down later to get good weight distribution. Thread on the nylock nuts and tighten them. See Figures 15 and 16.

When the weight distribution setup is complete, L-bracket nuts should be torqued to 45 ft-lb.

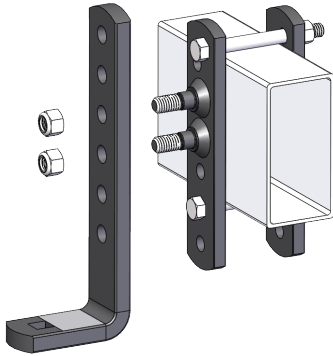

Figure 15 - Initial position for top-mounted coupler.

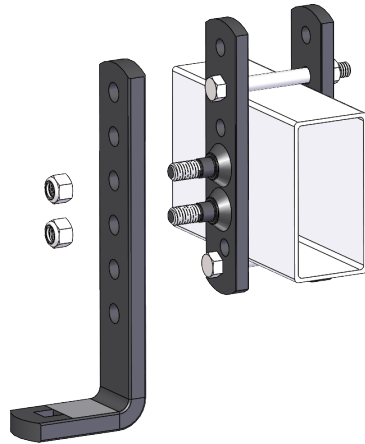

Figure 16 - Initial position for bottom-mounted coupler.

Step 5 - Spring Bar Installation

Apply a thin layer of bearing grease around the top and bottom surfaces of the trunnion knuckle tube and 3/4" pin. The bars will fit either side of the hitch; they are not side-specific. See Step 10 - Regular Maintenance. Slide the trunnion knuckle between the plates on the hitch head. The bars should be angled down with the bare metal surface at the end of the bar facing the ground. Align the holes in the hitch head with the tube of the trunnion. Insert a 3/4" retaining pin and secure it with a

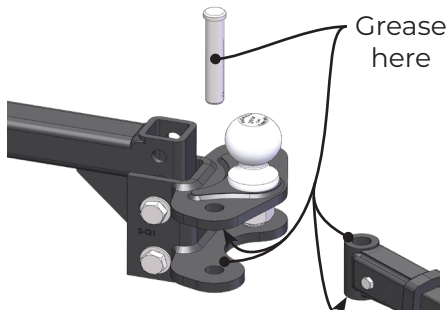

Figure 17

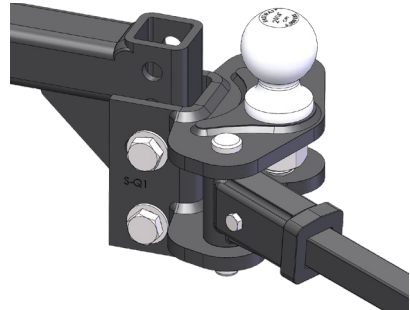

Figure 18

cotter pin. See Figures 17 and 18. Repeat for the 2nd bar. Wipe any excess grease from the bottom of the retaining pins.

Frequently apply a thin coat of bearing grease to the retaining pins, trunnion socket tubes, and the top and bottom surfaces where they meet the head plates. This will make assembly easier, and reduce hitch noise.

It is not necessary to apply lubricant to the joint where the spring bars rest on the L-bracket. This may decrease the amount of sway control provided by the hitch.

Step 6 - Weight Distribution Setup

Before starting the weight distribution setup, turn off or disable the auto-level system. See Appendix C, p. 28.

Good weight distribution is a critical component of the e2 hitch setup to get the best performance from your hitch. Every tow vehicle and trailer combination will react differently to weight distribution.

To correctly set up weight distribution you must take three measurements at the front of your tow vehicle. See Figure 19. First, measure without the trailer coupled. Next, measure with the trailer coupled, but with no weight distribution. Third, measure with the trailer coupled and the spring bars in place.

Measure from the ground to fender through the center-line of the axle.

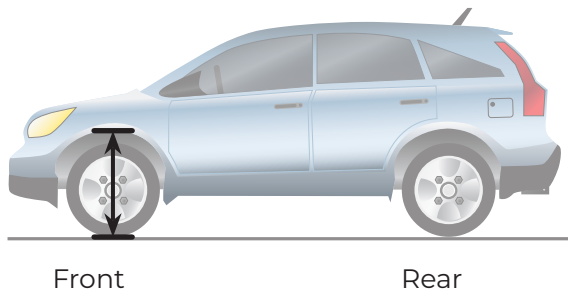

Weight Distribution Setup Table		FRONT	Example
A	Tow vehicle loaded for trip but still uncoupled from trailer		28"
B	Trailer coupled but NO weight distribution		30"
Calculate height halfway between A and B $(A+B) \div 2 =$			29"
C	Trailer coupled with weight distribution engaged. Should be at least halfway back to line A. Higher than this may still be under adjusted. Lower than line A is over adjusted. See Step 7 - Weight Distribution Adjustments.		$\frac{28''-29''}{29''-30''}$ Good Need More

Figure 19

Start by measuring the distance from the ground to the wheel well directly above the front axle with the trailer uncoupled. **Measure both driver and passenger sides, and use the average of these two.** Record this on **line A** of the weight distribution setup table. A temporary piece of masking tape placed on the fender gives a clean edge to measure to.

Back the tow vehicle to the trailer and lower the coupler onto the ball. Lock the coupler and retract the tongue jack until it raises off the ground about 1", so the full tongue weight of the trailer is resting on the hitch ball.

Measure the tow vehicle height again exactly above the front axle, to the same point that you measured to earlier when uncoupled. Record this on **line B** of the weight distribution setup table on p. 15.

With the tow vehicle still coupled to the trailer, use the tongue jack to lift both vehicles until you can swing the spring bars into place over the L-brackets. See Figure 20. Then, retract the jack.

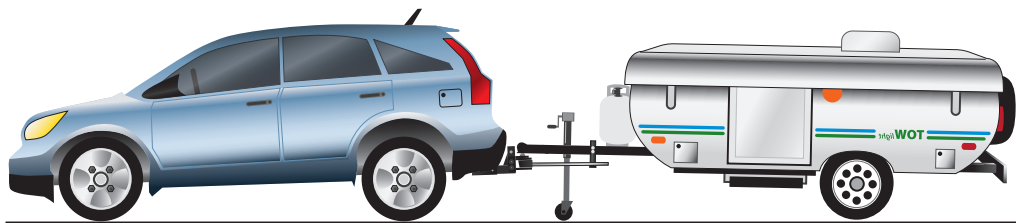

Figure 20

If you reach the top of the jack before the spring bars will swing into position, you can use the Snap-up lever to lift the spring bars up and onto the L-brackets. Use the L-pins to secure the spring bars on the L-brackets. See Figures 21 and 22.

With the spring bars resting on the L-bracket and the trailer and tow vehicle in line with each other, check to make sure there is a minimum of 3" from the end of the spring bars to the center of the L-brackets. See Figure 23. If necessary, unload the spring bars, then move and tighten the sway control bracket assembly.

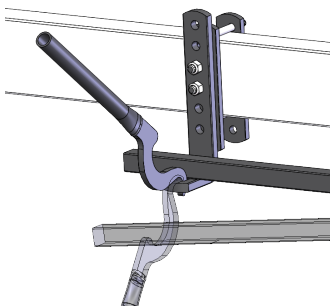

Figure 21

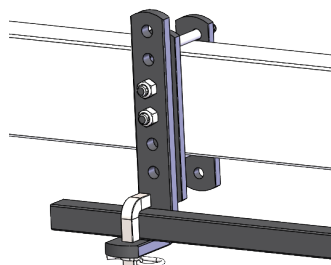

Figure 22

With the trailer coupled and weight distribution engaged (spring bars in place and jack retracted), measure the front wheel well height exactly as done before for lines A and B. Record this new measurement on line C of the weight distribution setup table on p. 15.

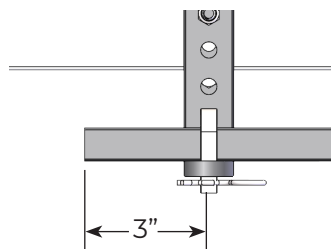

Figure 23

Step 7 - Weight Distribution Adjustment

⚠️ WARNING

Weight distribution is only one of many things that influences sway. The operator is responsible for making necessary adjustments to all contributing factors in order to minimize sway.

Good adjustment:

You have most likely achieved good weight distribution adjustment if your measurement on **line C** of the weight distribution setup table shows that front wheel well measurement is **at least halfway back** to the original uncoupled measurement. See **line C** on Weight Distribution Setup Table (p. 15) and Figure 24 below.

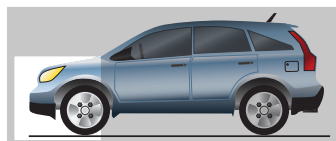

B coupled - no WD (dotted line)

C halfway back with WD (dotted line)

A uncoupled - - - - - (dashed line)

See Weight Distribution Setup Table on p. 15.

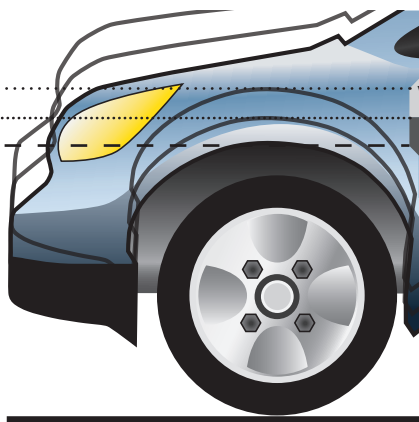

needs more weight distribution

good adjustment

Figure 24

⚠️ WARNING

Over or under adjusted weight distribution decreases tow vehicle stability.

Fixing Under or Over Adjustment:

If the hitch is transferring too little or too much weight, you must make adjustments to the hitch setup. For changes during the initial setup we recommend adding or removing spacer washers first to try and keep the spring bars parallel with the trailer frame. This gives you more adjustment options later if needed, and may also reduce some noise.

Once the maximum (3) or minimum (1) number of spacer washers has been reached, further adjustments can be made by raising or lowering the L-brackets. Minor adjustments later for changes in loading can usually be done by moving only the L-brackets.

The distance from the tow vehicle rear axle to the hitch ball significantly affects how the tow vehicle reacts to weight distribution adjustments. The same washer or L-bracket change will have varying results on different vehicles.

Under adjustment occurs when there is not enough weight being transferred to the front axles of the tow vehicle. See Figure 25.

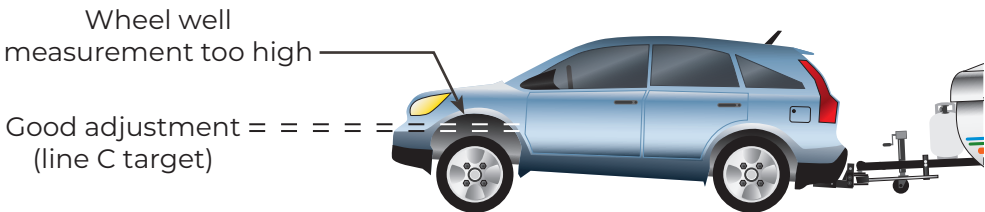

Figure 25 - Under-adjustment

If the measurement on **line C** is still higher than the calculated halfway point, you need more weight distribution adjustment (see **line C** on Weight Distribution Setup Table, Figure 19). With an under-adjusted setup your hitch is not unloading the rear axle sufficiently, giving back as much steering control as it could, nor is it providing as much friction as it could to help reduce trailer sway.

To correct under adjustment you must add more weight distribution force to the hitch by adding spacer washers, or raising the L-brackets.

If this is the initial set up, use the tongue jack to unload the spring bars. Remove the spring bars from the hitch head. Uncouple the trailer and pull the tow vehicle forward. Remove the hitch head and add a spacer washer. Repeat step 6 and 7 to readjust and check weight distribution.

If you have reached the maximum number of spacer washers (3), or if adjusting temporarily due to a change in vehicle loading, use the tongue jack to unload the spring bars. Raise the L-brackets one hole. Move the spring bars back over the L-brackets and retract the tongue jack. Measure the wheel wells and check for proper weight distribution.

Repeat Steps 6 and 7 until the measurements show that the hitch is distributing weight well.

Over adjustment occurs when there is too much weight being transferred to the front axle of the tow vehicle. See Figure 26.

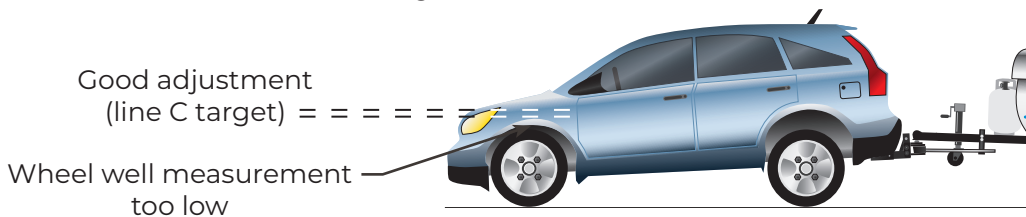

Figure 26 - Over-adjustment

If **C** is lower than **A**, you need less weight distribution adjustment (see **line C** on Weight Distribution Setup Table, Figure 19).

Over adjustment is a very dangerous situation where loss of control and jack-knifing is possible, especially in wet or slick road conditions and/or with heavy trailers.

To correct over adjustment you must take some of the weight distribution force out of the hitch by removing spacer washers, or lowering the L-brackets.

If this is the initial set up, use the tongue jack to unload the spring bars. Remove the spring bars from the hitch head. Uncouple the trailer and pull the vehicle forward. Remove the hitch head and remove a spacer washer. Repeat Steps 6 and 7 to adjust and check weight distribution.

If you have reached the minimum number of spacer washers (1), or if adjusting temporarily due to a change in vehicle loading, use the tongue jack to unload the spring bars. Lower the L-brackets one hole. Move the spring bars back over the L-brackets and retract the tongue jack. Measure the wheel wells and check for proper weight distribution.

Repeat Steps 6 and 7 until the measurements show that the hitch is distributing weight well.

Step 8 - Trailer Pitch Adjustment

After achieving a good weight distribution setup you may need to adjust the pitch (angle or attitude) of the trailer. Step back and look at the trailer to see if the front appears to be tipped up or down excessively.

Measure the front and rear of the trailer again at the same points you did when setting the trailer parallel to the ground in Step 3. Record these measurements on the Trailer Pitch Adjustment chart. See Figure 27.

Find the difference between the front and rear heights.

Trailer Pitch Adjustment Chart	Actual	Example
Highest Measurement		20
Lowest Measurement	-	- 18
Difference between highest and lowest		2

Figure 27

If the difference between the highest and lowest measurement is 1-1/4" or more, adjust the hitch ball height. If it is less than 1-1/4" different, complete Step 9 and tow a short distance with this setup to see how it handles before making any adjustments.

If the **higher** measurement is the front of the trailer, move the hitch head down one hole position on the shank. If the **lower** measurement is the front of the trailer, move the hitch head up one hole position on the shank.

Adjustments made to the ball height affect how weight is distributed. Moving it up slightly reduces the amount of weight distribution you get from a particular setup. Moving it down slightly increases the weight distribution from that same setup.

After making an adjustment to the ball height, return to Step 6 and 7 to check the weight distribution measurements again. Adjust the weight distribution if necessary until it falls within the guidelines. Check the trailer pitch again to see the difference made by moving the hitch ball height. You may need to try several setups before you get one that achieves good weight distribution and trailer pitch.

Step 9 - Final Tightening

WARNING

Do not tow your trailer until all bolts and nuts have been checked and properly tightened, and all pins and clips are securely in place.

Towing with loose bolts for an extended period of time can cause abnormal stress on the hitch resulting in accident, severe injury, and property damage.

After you have made proper adjustments to the hitch to give your setup good weight distribution and trailer pitch, tighten all of the nuts and bolts completely.

Unhitch the trailer and pull the tow vehicle forward a few feet to give yourself working room. Remove the spring bars from the hitch head.

Remove the hitch head from the receiver, turn the assembly upside down, and place it back into the receiver tube. Replace the hitch pin to secure it temporarily.

Use the torque wrench to tighten both 16mm shank bolts to 130 ft-lb.

Snug the angle set bolt to the shank again if needed. Tighten it 1/4 to 1/2 turn after it comes into contact with the shank. It should be tight enough to wedge the head against the shank, but do not overtighten the angle set bolt.

Torque the link plate mounting bolts to 27 ft-lb. Torque the L-bracket mounting nuts to 45 ft-lb.

Return the hitch head assembly to the upright position, and pin it into the receiver. Replace the spring bars. Couple the trailer again to the tow vehicle, and engage the hitch, securing the spring bars with the L-pins and clips.

You are now ready to take the trailer out for a tow. Remember to connect the breakaway cable, safety chains, and electrical cables. Make sure your trailer brake control is correctly adjusted. Retract the jack completely. Tow carefully at first and pay attention to how it feels. Follow the **Troubleshooting Guide in Appendix A**, which suggests ways that can help improve your towing experience if needed.

Step 10 - Regular Maintenance

The contact points of the head and spring bars, as well as the hitch ball, should be kept clean and well lubricated with a good quality bearing grease. See Figure 28. They should be cleaned and lubricated before each trip. Check for damage or abnormal wear at the beginning of each tow and replace parts if necessary. Use a rag to clean dirt and road grit from all contact points regularly.

All nuts and bolts should be checked before each tow and tightened or replaced if necessary.

Pay special attention to the angle set bolt. There is a break-in period unique to each hitch and towing configuration. With use, the spacer washers and rivet may compact slightly, leaving a small gap between the

Torque Spec Summary	
Shank bolts	130 ft-lb
Link plate bolts	27 ft-lb
L-bracket nuts	45 ft-lb
Angle set bolt	Tight + 1/2 turn

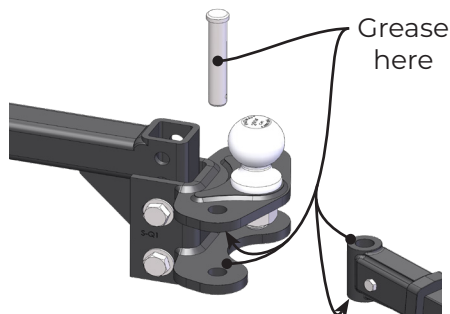

Figure 28

angle set bolt and the shank. The bolt should be checked frequently when your hitch is new and tightened as explained in Step 9. You will notice that over time the need to tighten the angle set bolt will diminish, but you should still check it regularly before each tow as part of your hook-up routine.

Store your hitch out of the weather when not in use. Keep it clean and free from rust. From time to time, use a good quality rust inhibiting spray paint to touch up the finish and keep it looking good. Do not paint over the warning stickers. If the warning stickers become worn or unreadable, contact Fastway Trailer Products for free replacements.

Step 11 - Hitching Up

Chock the wheels on both sides of the trailer.

Place the e2 head and shank assembly in the receiver hitch, and pin it into place.

Back the tow vehicle up to the trailer, and align the hitch ball directly under the socket of the trailer coupler. See Figure 29.

Set the parking brake.

Insert the e2 spring bars into the hitch head on both sides. Make sure the retaining pins lock them into place.

Lower the trailer coupler onto the hitch ball, and latch the coupler so that it's locked on the ball. See Figure 30.

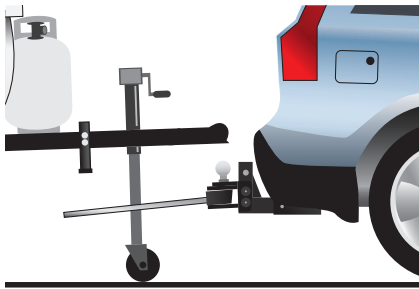

Figure 29

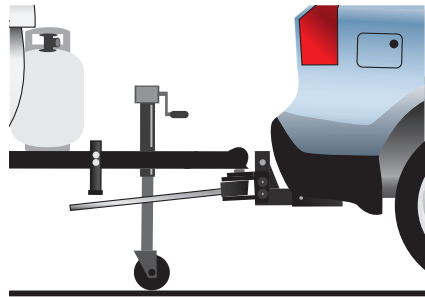

Figure 30

Using the tongue jack, raise the trailer and back of the tow vehicle together. See Figure 31. As you raise them, you will see the back ends of the spring bars rise in relation to the L-brackets. Raise the trailer until the ends of the spring bars are high enough to be pushed in place over the L-brackets.

If your jack is fully extended before you can get the spring bars over the L-brackets, use the Snap-up lever to lift the bars in place. Using a block or a jack extension foot, like the Fastway FLIP™ automatic jack foot, may be helpful to get the spring bars



Figure 31

high enough to easily move them in place.

Swing the spring bars into place over the L-brackets and secure them with the L-pins.

Retract the jack, lowering both the trailer and tow vehicle together, until the jack is completely retracted. See Figure 32. The spring bars are now engaged, and are distributing weight to the front axle of the tow vehicle, as well as providing built-in sway control.

The hitch is now ready for towing.

Secure the safety chains, breakaway cable, and wiring harness. Remove the wheel chocks and make any other preparations before towing.

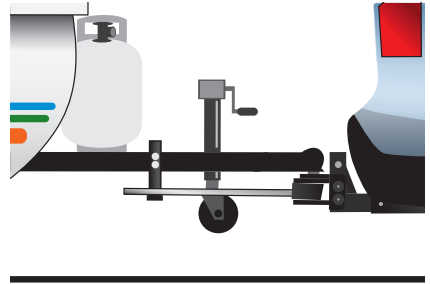

Figure 32

Step 12 - Unhitching

Maneuver the trailer into the desired position.

Set the parking brake, and chock the wheels on both sides of the trailer.

Unhook the safety chains, breakaway cable, and wiring harness from the tow vehicle.

With the trailer still coupled to the tow vehicle, extend the tongue jack on the trailer to lift both trailer and tow vehicle enough that the weight is lifted off the end of the e2 hitch spring bars and they are allowed to move freely side to side without being held by the friction on the L-bracket plate. See Figure 33. A block or jack extension,



Figure 33

like the Fastway FLIP automatic jack foot, may be helpful to lift the vehicles high enough to release the tension on the spring bars.

Remove the L-pins.

Swing the spring bars outward, away from the frame, enough that they will easily clear the L-brackets as they are lowered.

Retract the tongue jack, and lower both trailer and tow vehicle back down until enough trailer tongue weight is resting on the hitch ball that the coupler latch can be released. See Figure 34. This is usually indicated by the top of the shank slightly dropping away from the top of the receiver hitch tube.

Release the trailer's coupler latch.

Use the tongue jack to lift the trailer off of the hitch ball. See Figure 35.

Move the tow vehicle away from the trailer.

Remove the spring bars from the hitch head.

Store the spring bars and hitch head in a secure location protected from moisture and theft.

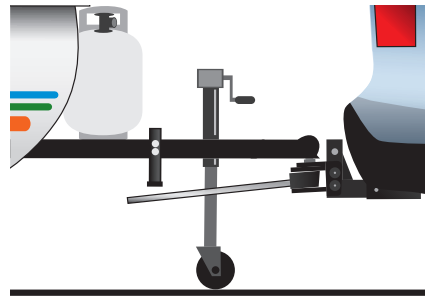

Figure 34



Figure 35

Appendix A - Troubleshooting Guide

Problem	Possible Cause	Suggested Correction
<p>Trailer Sway: Remember that trailer sway is caused by the combination vehicle (tow vehicle/trailer) configuration, loading, or outside forces. If you are unsure what may be causing your sway issues, contact your dealer or Fastway customer support for assistance. 877-523-9103 support@fastwaytrailer.com</p>	Light tongue weight	Get gross trailer weight (GTW) and tongue weight (TW). TW should be at least 10% of GTW. Follow the trailer manufacturer's guidelines for TW. Reposition the load in the trailer as needed to achieve correct TW/GTW ratio. Remove cargo carriers or 2nd trailer from rear of trailer. See Appendix B.
	Improperly rated or under-inflated tires	Inflate tires correctly, or replace with properly rated tires.
	Tow capacity exceeded	Reduce TW and GTW or use a tow vehicle with sufficient tow ratings. DO NOT TOW if either capacity is exceeded.
	Hitch undersized	Check to make sure your GTW and TW do not exceed your hitch's tow ratings. If either does, DO NOT TOW. Purchase an e2 hitch with a higher rating.
	Not enough weight distributed	Follow the instructions to correct underadjustment (Step 7) by adding spacer washers or raising the L-brackets. See Appendix B.
Tow vehicle too high in front		
Front end feels floaty		
Trailer nose is too high or too low	Incorrect shank	Consult your local e2 hitch dealer about using a specialty shank.
		Use the Shank Selector tool on fastwaytrailer.com to determine the correct shank for your setup.

Trailer nose is too high or too low (cont.)	Incorrect hitch ball height	Follow Step 8 - Trailer Pitch Adjustment to change the hitch ball height.
Bent or broken L-bracket, L-pin, or link plate	Sway control bracket installed too far back from the hitch ball center	Follow Step 4 and set the center of the sway control bracket between 25" and 30" from the center of the coupler socket.
	Link plates not installed upside down for bottom-mount coupler	Follow Steps 4 and 9 to install and tighten sway control brackets correctly.
Sway control brackets slide forward or backward along the trailer frame while towing.	Link plate not tight enough	Follow Steps 4 and 9 to tighten the link plates correctly.
Creaking and groaning noise	Dirty or dry friction surfaces in the hitch head	Clean and lubricate the hitch ball and other friction surfaces of the head and spring bars (Step 10) using a high quality bearing grease.

Noise

Noise is a normal occurrence when towing a trailer and using any weight distribution or sway control hitch.

The majority of hitch noise can be eliminated by lubricating the hitch ball and other friction surfaces of the head as shown in Figure 28.

If after lubricating the hitch you still experience some noise, do not be alarmed. This is generally caused by the friction between the spring bars and L-brackets, which means you are getting good sway-resisting friction from your hitch.

Adjusting the preload angle of the hitch head and L-bracket height so the bars are more parallel to the frame when towing and sit flat on the L-brackets can also help reduce noise.

Customer Support

For customer support, replacement parts, and accessories, call our toll free customer support line: 877-523-9103, or visit our website: fastwaytrailer.com.

Appendix B - Weight Distribution Adjustments

Study the following concepts and their effects on your vehicles when setting up your hitch for the first time, and when adjusting your hitch before each trip:

Tow vehicle rear axle to hitch ball distance: A longer distance will transfer less weight distribution than a shorter distance, with the same spacer washer and L-bracket settings.

Vehicle suspension: Soft suspensions, such as an SUV, will react farther and faster to weight distribution adjustments than stiff suspensions like a 3/4 ton pickup. For a smoother ride, some vehicle suspensions are designed to be very soft with the first few pounds of payload, and to then stiffen as the load increases. This means that initially the springs give way easily with very little weight applied, then later allow less movement, even with a significant change in applied weight.

Trailer axle to coupler distance: Trailers with longer distance will try to force distributed weight forward to the tow vehicle before absorbing it into the trailer suspension. Trailers with shorter distance absorb more of the distributed weight into their own suspensions.

Tongue weight: To operate effectively, your tongue weight should be at least 10% of the gross trailer weight. This makes the trailer more stable and helps provide the movement resisting friction on the L-brackets, and therefore the resistance to trailer sway.

Trailer loading: This is one of the most significant factors that influences trailer sway. Most trailers are designed to have a tongue weight of between 10% and 15% of the gross trailer weight. Always follow the trailer manufacturer's guidelines for tongue weight. A tongue weight that is too light will make the trailer more likely to sway. Trailer loading changes tongue weight dramatically, and loading can change dramatically from one trip to the next, or even during the course of a short weekend trip.

For example: full fresh water and/or full propane tanks that are tongue weight when you leave can empty and become full waste tanks that subtract tongue weight for the return trip. Shifting 40 gallons of water from the front to the back of your trailer can change 330 lb of positive tongue weight to 330 lb of negative tongue weight.

Rear-load toy haulers are designed to have a heavier dry (empty) tongue weight so when they are loaded with toys they become a more balanced load.

Front-load toy haulers are exactly the opposite. They have heavier tongue weight with toys loaded and lighter tongue weight without toys. Be careful not to exceed receiver hitch and tow vehicle rear axle ratings when towing with a front-load toy hauler.

All toy haulers may require significant changes to weight distribution setups between towing loaded and towing unloaded.

Cargo carriers, bike racks, and second trailers attached to the rear bumper of a trailer add weight to the rear of the trailer that automatically subtracts tongue weight. We recommend you do not add weight of any form to the rear bumper of your trailer. We also recommend that you do not tow a 2nd trailer.

Trailer coupled attitude: Attitude or pitch refers to the angle the trailer is tipped up or down. It is generally accepted that a trailer should be towed sitting parallel to the ground, or with the front (coupler) tipped slightly down. The front tipped too far up or down may be an indication of improper trailer loading, or a need to adjust the ball height or weight distribution settings.

Vehicle weight ratings: Each trailer and tow vehicle has a maximum Gross Vehicle Weight Rating (GVWR). The tow vehicle and towing equipment, including receiver, shank, hitch, and hitch ball all have maximum weight ratings for tongue weight and trailer weight. Tow vehicle and trailer also have maximum axle weight ratings. Never exceed any of these ratings.

Appendix C - Installing With Auto-Level/Air Bags

Always refer to and follow your tow vehicle owner's manual or air bag instructions for their requirements for use while towing.

Step 1 - Ready the Tow Vehicle and Trailer

The tow vehicle auto-level or suspension air bags should be set to normal ride height and/or air pressure before setting up the hitch and while towing. Turn off or disable these systems during the hitch setup process. Allow the suspension to adjust to normal position before turning it off. To turn the auto-level off, the system may have an off switch, a jack mode setting, or you may need to turn off the vehicle. The auto-level feature, or making adjustments to air bag pressure after setting up the hitch can greatly affect the weight distribution provided by the hitch, most likely decreasing it. Refer to your tow vehicle and/or air bag owner's manuals for additional information.

Steps 6 and 7 - Weight Distribution Setup and Adjustments

If the tow vehicle is equipped with auto-level that cannot be disabled while driving, weight distribution should be set to be slightly over adjusted before turning on the system. This means returning the front axle height to be between slightly more than one-half (50%+) to all the way (100%+) back to the baseline front axle measurement (weight). See **line A** on p. 15. After setting up the hitch, turn on the system, allowing it to auto-level. Measure the front as you did for the **line C** measurement, and write this measurement next to the first for later reference.

If the system has leveling only on the rear axle, the new measurement and

corresponding weight distribution calculation will be reasonably accurate.

If the system adjusts both front and rear axle heights, this new measurement will only be a reference measurement or estimate of the current weight distribution. It may no longer correlate to the load on the front axle when compared with previous measurements since the height may have been adjusted by the auto-level system. The true weight distribution numbers must be obtained at a CAT scale.

Step 8 - Trailer Pitch Adjustment

After achieving good weight distribution with auto-level engaged, trailer pitch may need to be adjusted.

Before checking, start the vehicle and make sure the auto-level system is on and has leveled the vehicle until it stops moving. Measure the trailer as described in Step 8 and make any required adjustments to the hitch setup.

Step 11 and 12 - Hitching Up and Unhitching

Before hitching up or unhitching, set the leveling system to normal ride height, then turn off the auto-level system by turning off the vehicle or, if equipped, placing the system in jack mode.

Warranty

Limited 10 Year Warranty: Progress Mfg. Inc. warrants the e2™ hitch against latent defects in materials and workmanship under normal use and service, ordinary wear and tear is excepted, to the original owner for a period of 10 years from the first date of purchase at retail up to the value of its original purchase price. If this product is latently defective it will be replaced or repaired when a proper return authorization is obtained and the product is returned with transportation charges prepaid to Progress Mfg. Inc. Progress Mfg. Inc. shall not be required to replace or repair any products damaged as a result of improper installation, alteration, unreasonable use, or improper maintenance including, without limitation, loading the product beyond the factory rated load capacity. This warranty does not include labor charges nor does it include transportation charges for returning the product to the consumer. To the extent allowed by law, Progress Mfg. Inc. shall not be liable for any incidental, consequential, or any other damages including, without limitation, breach of any implied warranty, merchantability, or fitness for a particular purpose of any e2 product. In no event shall Progress Mfg. Inc. be liable for any damages other than the replacement or repair of the affected part. Authorization and warranty procedure may be obtained by calling Progress Mfg. Inc. customer service at 877-523-9103.

Submit your warranty registration online at fastwaytrailer.com.

Service Tech and Experienced Installer Check List

Step 1

Park the loaded tow vehicle and trailer on a level surface.

Step 2

Install the hitch ball. If already installed, check that the ball is in good condition and is tight on the hitch head.

Step 3

Measure from the ground to the trailer coupler.

Secure the adjustable shank in the receiver with the hitch pin and clip.

Insert the spacer rivet with washers into the back of the hitch head to preload the angle of the hitch head.

Slide the hitch head bolt channel around the shank and hold the hitch head so that the top of the hitch ball measures between 0" - 1" higher than the coupler height. Use a specialty shank if needed.

Insert the shank bolts, washers, and nuts to attach the head to the shank.

Tighten the angle set bolt.

Step 4

Determine which coupler style you have before installing the link plates.

Measure 30" from the coupler along the trailer frame. Install the link plates with their centers between 25" and 30", as far back as the frame will permit.

Pinch the link plates tight to the frame and tighten the bolts evenly.

Install the L-brackets.

Step 5

Take initial measurements at the front axle for weight distribution - uncoupled and coupled with no weight distribution.

Lift the spring bars onto the L-brackets, retract the jack and engage the weight distribution.

Step 6

Check for good weight distribution and make needed adjustments.

Step 7

Check the trailer pitch and make needed adjustments.

Step 8

Check that all bolts and nuts have been properly tightened and that all pins and clips are securely in place.

Step 9

Give the owner's manual to the customer.

More Great Fastway Towing Accessories

ONESTEP™

STABILIZING WHEEL CHOCK

The Fastway® ONESTEP™ wheel chock positively locks both wheels in place, allowing you to freely move in your trailer, with virtually no wheel movement. No other wheel chock delivers more wheel stabilization than the ONESTEP.



ZIP™

BREAKAWAY CABLE

The Fastway ZIP™ breakaway cable provides a safer and more effective connection to your trailer, because it doesn't rust, fray, or become damaged while towing. This keeps you and your trailer safer. It meets or exceeds all DOT requirements, and protects your fingers from loose, sharp wires.



More Great Fastway Towing Accessories

FLIP™

AUTOMATIC
JACK FOOT

The Fastway FLIP™ automatic jack foot extends your trailer jack by up to six inches, eliminating 50 cranks both up and down, saving you time and effort. It provides more safety and stability for your trailer, and eliminates the time and effort it takes to search for and store wood blocks to put under your tongue jack.



FORTRESS™

COUPLER LOCK

The Fastway FORTRESS™ coupler lock fits virtually all 1-7/8", 2", and 2-5/16" trailer couplers. The wide shackle has deep teeth for a strong locking mechanism, and the super-hardened steel keeps your trailer safe.



353 South 1100 West
Provo, Utah 84601
Toll Free: 877-523-9103
Fax: 801-377-6616

fastwaytrailer.com

FASTWAY TRAILER PRODUCTS - FASTER, EASIER.™