

**SUPERLIFT SUSPENSION SYSTEMS**

300 Huey Lenard Loop Rd.
West Monroe, Louisiana 71292-9421
Phone: (318) 322-3458
Sales / Tech: 1-800-551-4955
FAX: (318) 323-5995
Web Site: www.superlift.com

**Superlift 6" lift system for 1999 and newer
Chevrolet Silverado / GMC Sierra 3/4-ton 4WD
INSTALLATION INSTRUCTIONS**

INTRODUCTION

Installation requires a professional mechanic. Prior to beginning, inspect the vehicles steering, driveline, and brake systems, paying close attention to the track bar, suspension link arms and bushings, anti-sway bars and bushings, tie rod ends, pitman arm, idler arm, ball joints and wheel bearings. Also check the steering sector-to-frame and all suspension-to-frame attaching points for stress cracks. The overall vehicle must be in excellent working condition; repair or replace all worn parts.

Read instructions several times before starting. Be sure you have all needed parts and know where they install. Read each step completely as you go.

NOTES:

- The factory steering stabilizer cylinder, if equipped, will not fit the Superlift components. Order part #92040 for replacement.
- A replacement front driveshaft is necessary if the truck is equipped with an Autotrac transfer case; refer to step 27.
- The rear lift is sold separately and includes separate instructions.
- A special tool is required to load / unload the torsion bars (step 2). Other special tools are recommended to detach / attach the pitman / idler studs. Refer to the factory service manual.
- Front end realignment is necessary.
- Exhaust modification is necessary. Refer to step 27.
- This system utilizes the stock torsion bars, which normally yield the best ride quality. But, if the "final product" ride and handling seems too soft, heavier Gross Vehicle Weight Rating (GVWR) bars can be installed. Generally, heavier torsion bars are only needed to compensate for the extra weight of a winch or snowplow, or when the truck is subjected to extreme off-road use. Also, wider tires and wheels proportionally increase the leverage on the bars, which results in a lower ride height and a "spongier" ride. GM offers various rated bars. Your vehicle's existing torsion bar rating can be identified by a 3-letter code stamped into the bar's ends. The code is also on an adhesive tag wrapped around the bars.
- An arrow on diagrams indicates which direction is toward the front of the vehicle.
- A foot-pound torque reading is given in parenthesis () after each appropriate fastener.
- Do not fabricate any components to gain additional suspension height.
- Prior to drilling or cutting, check behind the surface being worked on for any wires, lines, or hoses that could be damaged.
- After drilling, file smooth any burrs and sharp edges.

- Prior to operating a torch or saw, protect any heat-sensitive components located in the immediate area by covering them with a water-saturated cloth. Most undercoating are flammable but can be extinguished using a water-filled spray bottle. Have a spray bottle and an ABC rated fire extinguisher on hand.
- Paint or undercoat all exposed metal surfaces.
- Prior to attaching components, be sure all mating surfaces are free of grit, grease, undercoatings, etc.
- A factory service manual should be on hand for reference.
- Use the check-off box “☐” found at each step to help you keep your place. Two “☐☐” denotes that one check-off box is for the driver side and one is for the passenger side. Unless otherwise notes, always start with the driver side.

PARTS LIST ... The part number is stamped into each part or printed on an adhesive label. Identify each part and place the appropriate mounting hardware with it.

| PART NO | DESCRIPTION (Qty.- if more than one) | NEW ATTACHING HARDWARE (Quantity) |
|-----------------|--|---|
| 55-01-3290..... | upper control arm bracket, front, driver side | (1) 9/16" x 3-3/4" bolt (2) 9/16" USS washer (1) 9/16" nyloc nut (1) 1" x 1-13/16" spacer sleeve (1) 7/16" x 1" tab bolt (1) 7/16" washer (1) nyloc nut |
| 55-02-3290..... | upper control arm bracket, front, passenger side | (1) 9/16" x 3-3/4" bolt (2) 9/16" USS washer (1) 9/16" nyloc nut (1) 1" x 1-13/16" spacer sleeve (1) 7/16" x 1" tab bolt (1) 7/16" washer (1) 7/16" nyloc nut |
| 55-03-3290..... | (2) lower control arm bracket, front | (2) 5/8" x 4-1/2" bolt (2) 5/8" nyloc nut (4) 5/8" USS washer |
| 55-04-3290..... | front crossmember..... | (8) 7/16" x 1-1/4" bolt (8) 7/16" nyloc nut |

| | | |
|------------|--|---|
| 55-05-3290 | upper control arm bracket, driver side, rear | (1) 9/16" x 3-3/4" bolt (2) 9/16" USS washer (1) 9/16" nyloc nut (1) 1" x 1-13/16" spacer sleeve (2) 1/2" x 1-1/2" bolt (2) 1/2" USS washer (2) 1/2" stover nut |
| 55-06-3290 | upper control arm bracket, passenger side, rear | (1) 9/16" x 3-3/4" bolt (2) 9/16" USS washer (1) 9/16" nyloc nut (1) 1" x 1-3/16" spacer sleeve (2) 1/2" x 1-1/2" bolt (2) 1/2" USS washer (2) 1/2" stover nut |
| 55-07-3290 | lower control arm bracket, driver side, rear | (1) 5/8" x 5-1/2" bolt (2) 5/8" USS washer (1) nyloc nut |
| 55-08-3290 | lower control arm bracket, passenger side, rear | (1) 5/8" x 5-1/2" bolt (2) 5/8" USS washer (1) nyloc nut |
| 55-09-3280 | differential drop bracket, upper, driver side | (1) 9/16" x 4" bolt (1) 9/16" nyloc nut |
| 55-10-3290 | differential drop bracket, passenger side | (2) 9/16" x 1-1/2" bolt (2) 9/16" thick washer (2) 9/16" USS washer (2) 9/16" stover nut |
| 55-11-3290 | rear crossmember | (4) 7/16" x 1-1/2" bolt (4) 7/16" nyloc nut |
| 55-12-3290 | steering centerlink | (2) 9/16" x 2" bolt (2) 9/16" stover nut |
| 44-04-3214 | C.S.S. link | (2) 9/16" x 3" bolt (2) 9/16" USS washer (2) 9/16" nyloc nut (4) bushing half (2) sleeve |
| 55-13-3290 | sway bar drop bracket, driver side | (2) 3/8" x 1-1/4" bolt (2) 3/8" nyloc nut |

| | | |
|-----------------|--|--|
| 55-14-3290..... | sway bar drop bracket, passenger side | (2) 3/8" x 1-1/4" bolt (2) 3/8" x 1-1/4" nyloc nut |
| 55-15-3290..... | torsion bar drop bracket,..... driver side | (6) 7/16" x 1-1/4" bolt (12) 7/16" flat washer (6) nyloc nut (2) bushing half (1) sleeve |
| 55-16-3290..... | torsion bar drop bracket,..... passenger side | (6) 7/16" x 1-1/4" bolt (12) 7/16" flat washer (6) nyloc nut (2) bushing half (1) sleeve |
| 55-17-3290..... | (2) kicker brace..... (optional) | (2) 9/16" x 4" bolt (2) 9/16" stover nut (2) 7/16" x 3-1/2" bolt (4) 7/16" flat washer (2) 7/16" nyloc nut (4) bushing half (4) sleeve |
| 55-18-3290..... | (2) lower shock mount, front | |
| 55-19-3290..... | (2) compression stop extension, rear | (4) 7/16" x 1-1/4" bolt (4) 7/16" nyloc nut |
| 55-20-3290..... | (2) brake hose bracket..... | (2) 1/4" x 3/4" bolt (2) 1/4" nyloc nut |
| 55-23-3290..... | front skid plate with large badge (optional) | |
| 55-24-3290..... | front differential skid plate..... (optional) | (2) 7/16" x 3-1/2" bolt (2) 7/16" x 2-3/4" bolt (8) 7/16" flat washer (4) 7/16" nyloc nut |
| | stock rear brake line bracket | (2) 1/4" x 1" bolt (2) 1/4" nyloc nut |
| 85287 | (2) shock absorber, front | (2) shock boot, yellow (2) hardware pack and cable tie |
| 85161 | (2) shock absorber, rear | (2) shock boot, yellow (2) hardware pack and cable tie |
| 0034..... | Superlift badge | alcohol wipe pad |
| 00461 | decals, "Warning To Driver" | |

FRONT DISASSEMBLY**1) PREPARE VEHICLE...**

- Place the vehicle in neutral. Raise the front of vehicle with a jack and secure a jack stand beneath each frame rail, behind the lower control arms. Ease the frame down onto the stands, place transmission in low gear or "park", and chock rear tires. Remove the front tires.

2) UNLOADING THE TORSION BARS...

WARNING: Be extremely careful when loading and unloading the torsion bars; there is a tremendous amount of energy stored in them. Keep your hands and body clear of the adjuster arm assembly and the puller tool in case anything slips or breaks.

- Mark the torsion bars to indicate driver and passenger side.
- A special torsion bar puller tool is required to unload the torsion bars. Use the tool to load the torsion bar, then remove the adjusting bolt and nut block. Unload the bar.

Note: Because of the extreme loads generated by the torsion bars on these vehicles, a standard two-jaw puller tool tends to bend the "lips" of the crossmember (which it uses for attachment) and may pop out of place. We have had the best results using a C-clamp type puller tool. If one cannot be found locally, this tool (PN J-22517-C) is available from the Kent Moore Tool Group in Roseville, Michigan (800/345-2233 or 313/774-9500).

- Once unloaded, scribe an alignment mark on each bar to indicate its indexing in relation to the adjuster arm and the lower control arm.
- Slide the torsion bar forward (into the lower control arm) and remove the adjusting arm.
- Remove the torsion bar crossmember and the related factory bracketry. Slide the torsion bars out of the lower control arms and set these parts aside.

3) BRAKE HOSE AND CALIPER...

- Unbolt the brake hose from the upper control arm, then unbolt the caliper from the knuckle and hang it out of the way using mechanic's wire. Be sure the brake hose isn't stretched or pinched. Retain all the factory hardware.

4) AXLE SHAFT...

- Remove the six bolts that hold the CV axle flange to the differential.

5) CENTERLINK...

- Note the factory positioning on the centerlink for proper positioning during assembly.
- Using a special puller tool (refer to the factory service manual), detach the tie rod end from the knuckle. Leave the tie rods attached to the centerlink.
- Detach the centerlink from the pitman arm and idler arm using the special tool and set the assembly aside. Retain all of the factory hardware.

6) SWAY BAR...

- Unbolt the sway bar links from the lower control arms, then detach the sway bar from the frame. Retain all the factory hardware and bushings.

7) CONTROL ARM / HUB ASSEMBLY...

- Disconnect the ABS wiring at each hub by unplugging the connector located at the top of the framerail. Carefully separate the wire from the clips on the upper control arm.
- Support the hub assembly using a floor jack. Remove the upper and lower control arm bolts at the frame, and with the help of an assistant, carefully lower the assembly to the floor.

NOTE: Some installers may find it easier to separate the upper and lower control arms from the knuckle and remove these pieces individually. This will require a special tool to detach the ball joints, but this extra step can make disassembly and reassembly much easier. Refer to the factory service manual for the proper disassembly procedures.

8) FRONT DRIVESHAFT...

- Detach the front driveshaft from the differential and retain the factory bolts and clamps. If a replacement front driveshaft has been purchased with the kit (required on all trucks with Autotrac full-time four-wheel drive capability), use a screwdriver to pry loose the clamp holding the rubber dust boot to the transfer case and slide the driveshaft yoke out of the case. Take precautions to ensure the rubber boot doesn't become ripped or torn because it will be reused with the new driveshaft. Set these parts aside. If a replacement front driveshaft has not been purchased, leave the driveshaft attached to the transfer case and tie it up out of the way.

9) SKID PLATE...

- Remove the differential skid plate and splash shield if so equipped.

10) DIFFERENTIAL WIRING...

- Disconnect the differential wiring and vent hose.

11) DIFFERENTIAL ASSEMBLY...

- Remove the factory rear crossmember.
- Support the differential with a floor jack. Remove the bolt that attaches the rear of the differential to the driver side lower control arm frame mount.
- Remove the two bolts that hold the differential on the passenger side.
- Remove the last bolt on the top of the differential on the driver side and carefully lower the differential assembly to the floor.

12) TRIM THE FRAME...

- [DIAGRAM 1] Trim the lower differential frame mount on the driver side as shown in Diagram 1 using a torch.

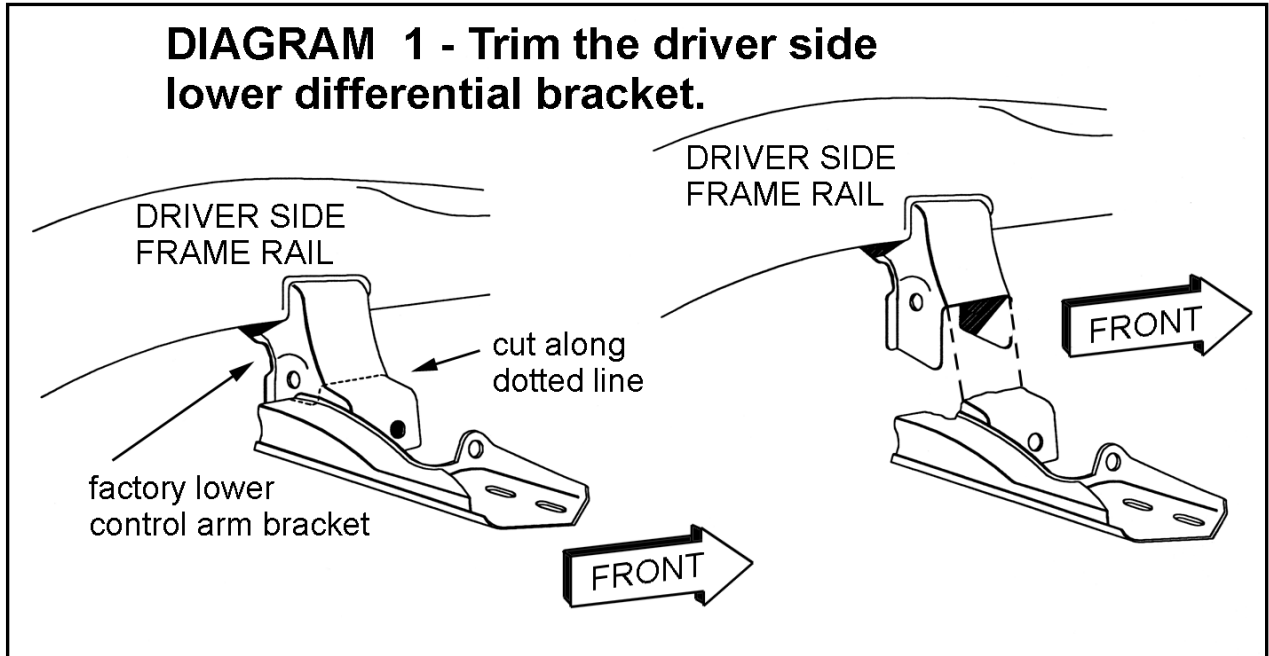

- [DIAGRAM 2A and 2B] Cut the extension travel stop and trim rear upper control arm bracket as shown in Diagram 2A and 2B using a torch. Note that a small corner piece of the travel stop brackets are retained to help reinforce the rear U.C.A. mount.

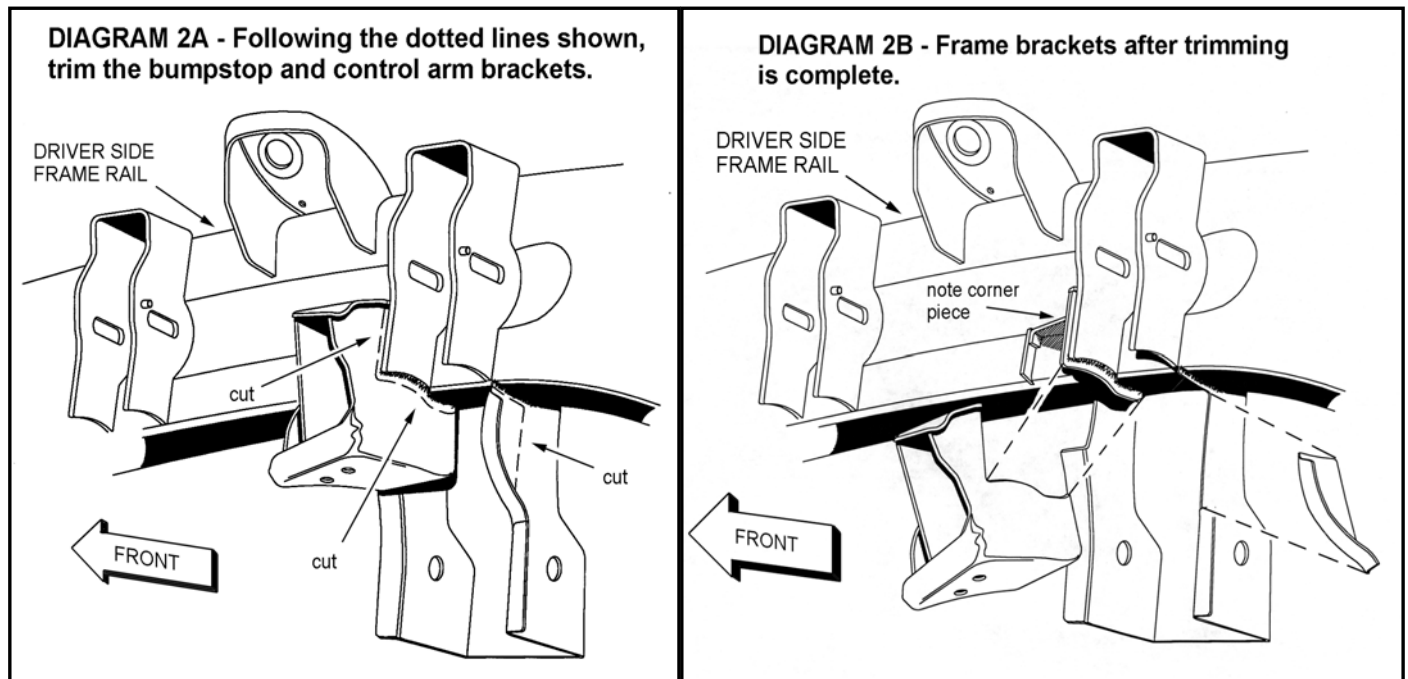

FRONT ASSEMBLY

13) CENTERLINK / STEERING STABILIZER...

- [DIAGRAM 3] Install the factory steering link in the Superlift centerlink (55-12-3290) using the supplied 9/16" x 2" bolts and 9/16" stover nuts. The L-shaped bends in the factory steering link should offset toward the rear of the vehicle as shown in Diagram 3. Tighten the nuts (82 lb-ft).
- If steering stabilizer #92040 is purchased, loosely install the stabilizer in the factory bracket on the front crossmember using the factory hardware. Be sure the body of the stabilizer is attached to the crossmember. Extend the stabilizer rod end approx. half way and let hang.

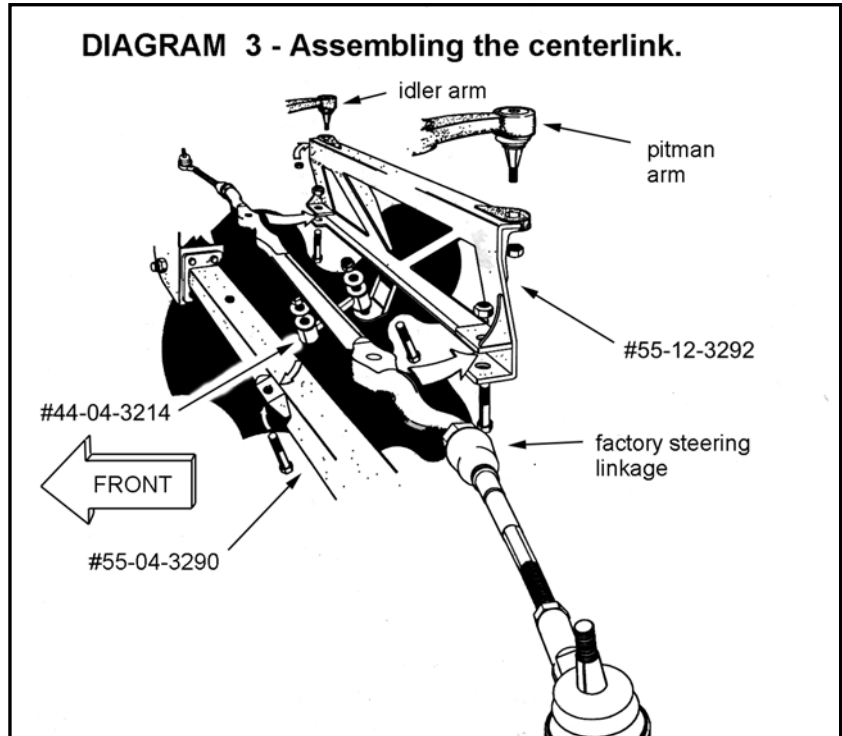

- Position the centerlink assembly so that the C.S.S. tab (the single tab at the center of the link) and steering stabilizer tab point toward the front bumper. Attach the centerlink to the pitman and idler arms. Reinstall the factory retaining nuts and tighten (46 lb-ft). The C.S.S. link (44-04-3214) will be installed in a later step.
- Install the supplied bushings and hardware, then attach the steering stabilizer rod in the centerlink. Tighten the stabilizer nut until the bushing swells slightly.

14) DIFFERENTIAL DROP BRACKETS...

- Attach the passenger side differential drop bracket (55-10-3290) to the factory differential bracket using the supplied 9/16" x 1-1/2" bolts and thick washers. The taper in this drop bracket should face rearward, leaving the differential mounting face more or less parallel to the ground. Do not tighten at this time.
- Install the driver side upper differential bracket (55-09-3280) in the factory frame mount using the supplied 9/16" x 4-1/2" bolt and nyloc nut. Do not tighten at this time.
- With the help of an assistant, raise the differential back into position and secure it to the driver side "09" bracket using the factory hardware. Do not tighten at this time.
- Attach the passenger side of the differential to the "10" bracket using the factory hardware. Do not tighten at this time.

15) UPPER CONTROL ARM BRACKETS, FRONT LEGS...

- Attach the driver side (55-01-3290) and passenger side (55-02-3290) front U.C.A. brackets to the existing U.C.A. mounts on the frame using the supplied 9/16" x 3-3/4" bolts and nyloc nuts. Snug the bolt, but do not thoroughly tighten at this time.
- Using a level or a plumb bob, check the alignment of the slotted holes in the "01" and "02" brackets with the slotted holes in the factory frame brackets. The slots in the Superlift brackets should line up vertically with the original slots. Make bracket adjustments as necessary until the slots are perfectly aligned.
- Note the hole located on the underside of the "01" and "02" brackets. Using the bracket as a template, mark the location of this hole on bottom of the frame. Remove the bracket and drill a 15/32" hole. Clean up any burrs with a file.
- Reinstall the bracket using the supplied hardware, including the 1-13/16" long spacer sleeve and 9/16" USS washers. Slide the 7/16" x 1-1/4" tab bolt into the square hole in the side of the frame and maneuver it through the previously drilled hole and U.C.A. bracket. Install the supplied 7/16" nyloc nut and USS washer and tighten (37 lb-ft).

16) LOWER CONTROL ARM BRACKETS, FRONT LEGS / FRONT CROSSMEMBER...

- Install the front lower control arm brackets (55-03-3290) on the driver and passenger side using the supplied 5/8" x 4-1/2" bolts and related hardware. These bolts should be installed from the front and will be tightened once the vehicle is on the ground.
- Install the front crossmember (55-04-3290) with the C.S.S. tab facing forward using the supplied 7/16" x 1-1/4" bolts and nyloc nuts. Tighten (37 lb-ft).

17) C.S.S. LINK...

- Coat the outside diameter of the supplied bushing sleeves with a light lithium or silicon-based grease. Install the bushings and sleeves in the C.S.S. link (44-04-3214).
- Position the centerlink so that the tires (if they were on the vehicle) would be pointing straight ahead. Following Diagram 3, install the C.S.S. link between the tab on the front crossmember and the tab on the centerlink using the supplied 9/16" x 3" bolts, 9/16" nyloc nuts, and USS washers. The grease fittings should be pointed toward the driver side, the bolts should be installed from the bottom, and the washers should be positioned under the nuts. Tighten the bolts until the bushings swell slightly.

NOTE: The bushings in the C.S.S. link should be flush with the mounting tabs. If they are not, stop and recheck previous installation procedures to ensure all the bracketry has been installed correctly. If the tabs are only slightly misaligned with the bushings, bend the tabs until the bushings are perfectly flush.

18) UPPER AND LOWER CONTROL ARM BRACKETS, REAR LEGS...

NOTE: The following steps are performed one side at a time. Start with the driver side.

- [DIAGRAM 4] Loosely attach the rear U.C.A. brackets (55-05-3290 driver side, 55-06-3290 passenger side) to the rear L.C.A. brackets (55-07-3290 driver side, 55-08-3290 passenger side) using the 1/2" x 1-1/2" bolts, 1/2" washers, and nyloc nuts as per Diagram 4. These will be tightened in a later step.

- Slide the above bracket assembly into the frame mounts for the upper and lower control arm rear legs as shown in Diagram 4. Install the 9/16" x 3-3/4" bolts and related hardware in the "05" and "06" brackets, and the supplied 5/8" x 4-1/2" bolts and related hardware in the "07" and "08" brackets. All the bolts should be installed from the front to avoid interference with other components. The hardware will be tightened in a later step.

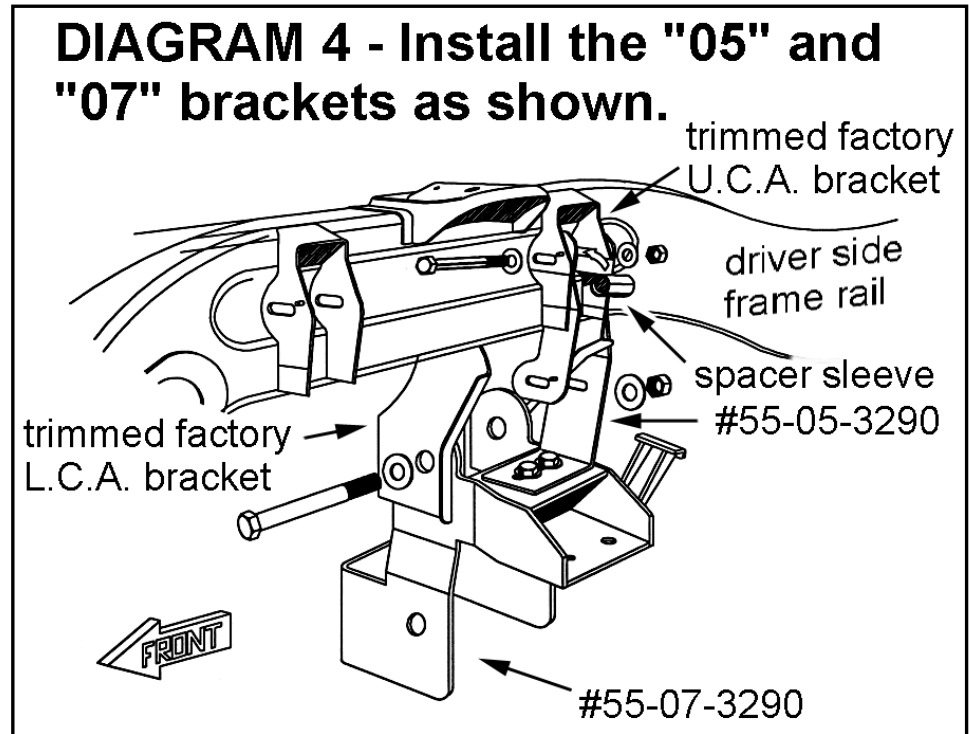

- Position the rear crossmember (55-11-3290) between the "07" and "08" brackets with the differential tab pointing toward the front bumper. Install the crossmember using the supplied 7/16" x 1-1/2" bolts, and tighten (37 lb-ft).
- Install the 9/16" x 3 1/2" bolt and stover nut through the rear crossmember tab, differential mount and lower control arm bracket.

19) KICKER BRACES...

NOTE: Kicker braces are optional with this suspension system and are purchased separately. If you have not purchased kicker braces, proceed to step 20.

- Coat the outside diameter of the sleeves with a lithium or silicon-based grease, then install the supplied bushings and sleeves in the back of the rear crossmember. Loosely attach the kicker braces (55-17-3290) to the rear crossmember using the 1/2" x 4" bolts and stover nuts.

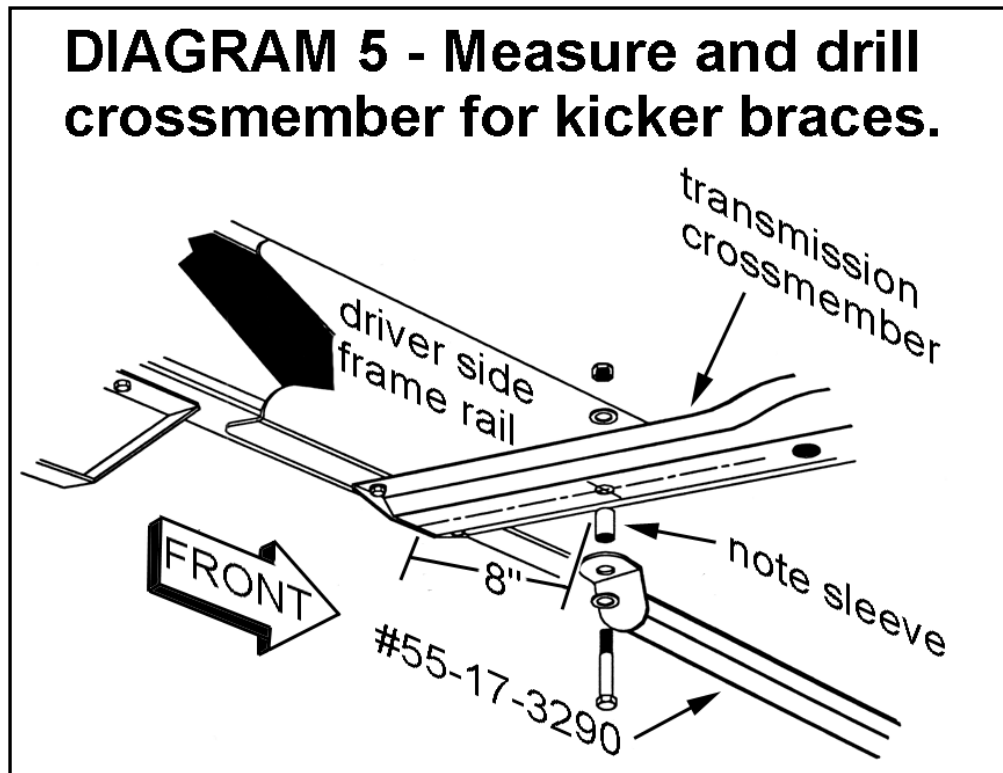

- [DIAGRAM 5] Using a straightedge and a ruler, mark a point approximately 8" from the edge and in the center of the transmission crossmember as shown in Diagram 5. Line up the hole in the end of the kicker brace with this point and scribe a mark where the hole should be drilled in the crossmember.
- Swing the kicker brace out of the way and drill a 7/16" hole all the way through the transmission crossmember. Now use a 5/8" drill bit to enlarge the first (or bottom) hole, and clean up any burrs with a file.
- Slide the supplied sleeve into the crossmember and secure the end of the kicker brace using the supplied 7/16" x 3-1/2" bolts, flat washers, and nyloc nuts and tighten (25 lb-ft).
- Tighten the other end of the kicker brace until the bushing swells slightly.

20) UPPER/LOWER CONTROL ARM ASSEMBLY...

NOTE: As mentioned in step 7, many installers will find it easier to separate the upper and lower control arms from the knuckle during disassembly and reassembly, while others prefer to install the assembly as one piece. We have found it easier to install the parts individually. If you choose to install the assembly as one piece, you will need one or two assistants.

- Install the upper and lower control arm assembly following the procedures in the factory service manual and using the factory hardware. **IMPORTANT:** The bolt that attaches the front leg of the lower control arm must be installed from the rear, while the bolt that attaches the rear leg of the lower control arm must be installed from the front.
- Install the cam bolts for the upper control arms in a centered, or neutral, position and discard the factory plastic retainers pressed into the cam slots. Snug all the control arm hardware; it will be fully tightened once the vehicle is on the ground.

21) HARDWARE TIGHTENING SEQUENCE...

- Visually inspect the position of the differential. The axle drive flanges should appear centered and not interfere with any hardware. Also verify that the centerlink does not hit the differential or any other brackets throughout the steering cycle. If contact or interference exists, adjust the position of the differential until all clearance problems are resolved.

- With the differential situated, torque these bolts in the following sequence:
 - 1) front upper diff. bracket 2 bolts (82 lb-ft)
 - 2) passenger diff. bracket 4 bolts (82 lb-ft)
 - 3) rear lower diff. bracket 1 bolt (82 lb-ft)
 - 4) frame-to-all U.C.A. drop brackets 4 bolts (82 lb-ft)
 - 5) frame-to-all L.C.A. drop brackets 4 bolts (112 lb-ft)
 - 6) "05"- "07" and "06"- "08" bolts 4 bolts (57 lb-ft)

22) AXLE SHAFTS...

- Line up the CV shaft with the axle flange on the differential and reinstall the factory hardware (six for each side). Tighten (60 lb-ft).

23) FRONT SWAY BAR AND TIE ROD...

- Install the front sway bar drop brackets (55-13-3290 driver side and 55-14-3290 passenger side) on the frame using the factory hardware.

- Reinstall the factory splash shield.

- Attach the sway bar (with the factory bushings and clamps) to the drop brackets using the supplied 3/8" x 1-1/4" bolts and tighten (23 lb-ft).

- Using the factory hardware and bushings, install the sway bar end links between the sway bar and lower control arm (24 lb-ft).

- Reattach the tie rod ends to the knuckles and tighten (33 lb-ft).

24) BRAKE LINES AND CALIPERS...

- Reinstall the brake calipers.

- Locate the small bracket on the frame that supports the connection between the steel brake line coming from the master cylinder and the rubber line that leads to the caliper. Carefully remove the retaining clip and unbolt the bracket from the frame.

- [DIAGRAM 6] Place the brake bracket approximately 1- to 1-1/2-inches down and 1" back from its factory position and scribe marks for two new mounting holes. Move the bracket, then drill one 17/64" hole and one 3/8" hole.

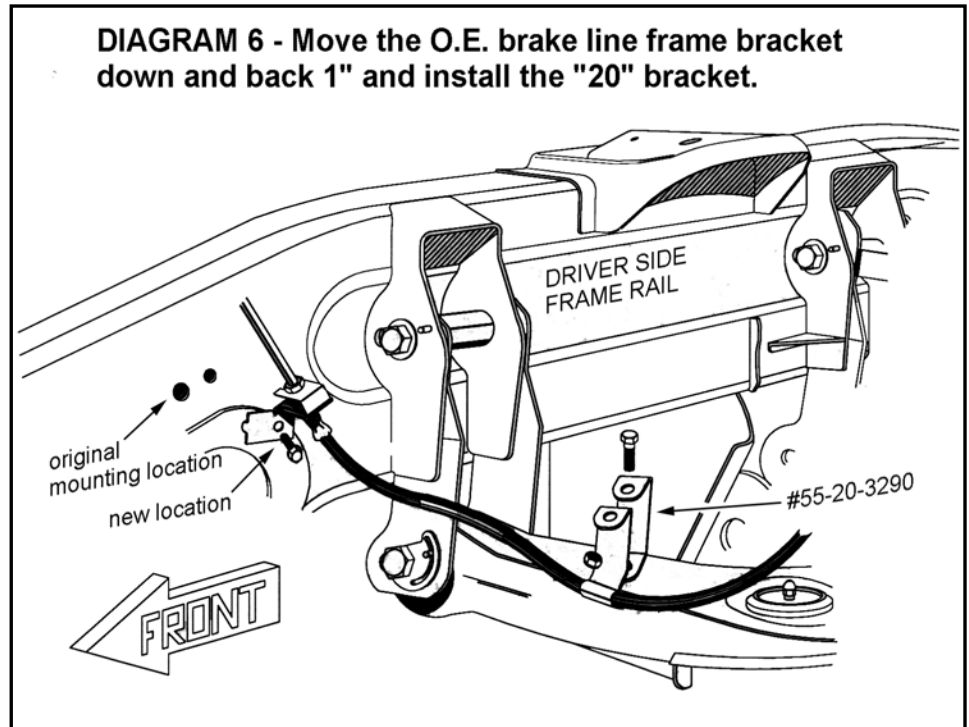

- Mount the bracket to its new location using the factory hardware and carefully bend the steel line to reach the bracket. Take precautions to avoid kinking the steel line, and make sure the line does not touch the frame or other components that could cause damage once the connection is resecured to the bracket.
- Install the brake hose relocation bracket (55-20-3290) on the upper control arm as shown in Diagram 6. Connect the factory brake line bracket clamped to the rubber line as shown using the supplied 1/4" x 3/4" bolts and related hardware. Tighten (9 lb-ft).
- Reattach the small brake hose locating bracket (closer to the caliper) to its factory location on the knuckle and tighten (9 lb-ft).
- Follow the factory routing for the ABS wire. The extra length needed to avoid overstretching the wire can be found by relocating the existing connector and its clip to a new position on the side of the frame. This may require drilling a small hole for the clip. Rearrange the other ABS wire retaining clips as necessary to ensure the wire can be protected from moving components and has the slack it needs for full extension and compression travel.

25) SHOCK ABSORBERS...

- Install the lower shock brackets (55-18-3290) in the factory location on the lower control arm using the stock hardware. Tighten (23 lb-ft).
- Install the bushings, boots, and stickers on the Superlift front shock absorbers (85287).
- Loosely install the bottom end of the shock to the lower control arm using the factory hardware. Extend the rod end to the upper shock mount on the frame, install the bushings and nut, and tighten the nut until the bushing swells slightly.
- Tighten the lower end of the shock until the bushing swells slightly.

26) DIFFERENTIAL WIRING / VENT HOSE...

- Reconnect the differential wiring and breather tube. Adequate vent tube and wire length can be found by rearranging the wire retaining clips and unwrapping a section of the tube from the wire loom inside the engine compartment.

27) FRONT DRIVESHAFT...

- Exhaust modifications are necessary due to inference with the front driveshaft. If necessary, the truck can be driven to an exhaust shop without the front driveshaft installed to have the necessary modifications performed.

NOTE: If your truck is equipped with the Autotrac, or push-button full-time capable, transfer case, purchasing a replacement front driveshaft is mandatory due to driveline vibrations caused by the factory front driveshaft when the truck is in fulltime four-wheel drive mode. This driveshaft is available separately from Superlift. Trucks equipped with the standard part-time lever-operated transfer case do not need this replacement driveshaft as long as speeds in four-wheel drive will not exceed 25 mph. If a replacement driveshaft is not purchased, proceed to step 28.

- Carefully remove the rubber dust boot located on the transfer case end of the factory driveshaft. Discard the factory clips and install the boot on the new driveshaft using the supplied clamp.
- Slide the splined end of the driveshaft into the transfer case first, then attach the other end using the factory U-bolt clamps and tighten. Push the rubber dust boot over the lip on the transfer case and secure it with the supplied clamp.

28) SKID PLATE...

NOTE: The optional skid plate is sold separately. If you have not purchased a skid plate, move on to step 29.

- Position the differential skid plate (55-24-3290) under the front and rear crossmembers. Line up the two rear holes of the skid plate with the rear crossmember and loosely install the 7/16" x 3-1/2" bolts and related hardware.
- Position the front skid plate (55-23-3290) flush with the front crossmember. Line up the holes of the "23" and "24" bracket with the mounting holes in the front crossmember and install the 7/16" x 2-3/4" bolts and related hardware. When both plates are properly aligned, tighten all the mounting bolts (37 lb-ft).

29) TORSION BAR DROP BRACKETS...

- ☐☐ [DIAGRAM 7] Following the diagram, scribe a straight line from the center of the factory torsion bar crossmember brackets (located near the top of the frame) to the bottom of the frame. Line up the center hole on the side of the Superlift torsion bar drop bracket (55-15-3290 driver side and 55-16-3290 passenger side) with this line and firmly clamp the bracket into place.

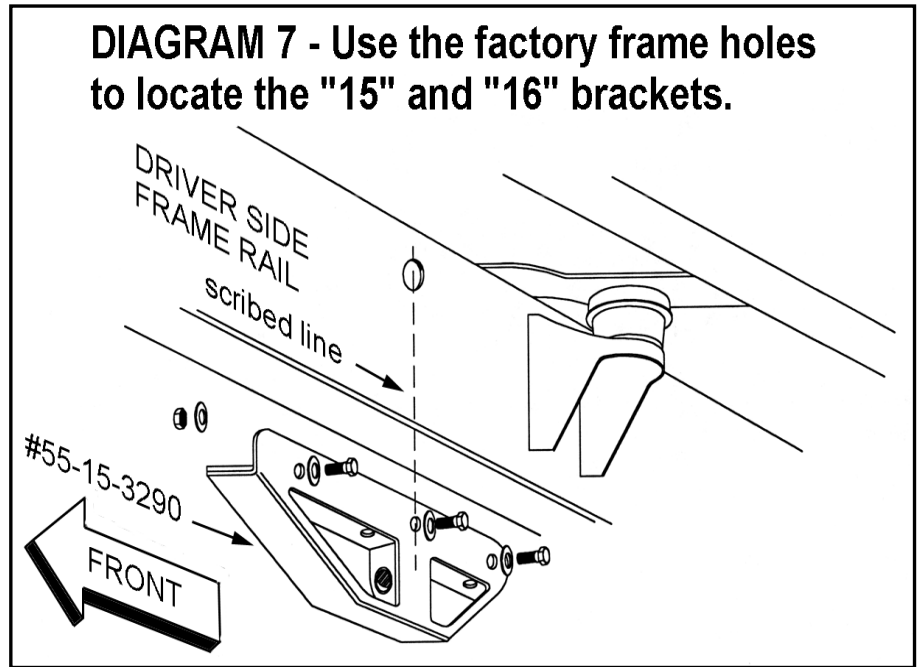

- ☐☐ Locate and install the appropriate bushings and sleeves (lubricate the outside of the sleeves with grease) for the "15" and "16" brackets.
- ☐☐ Scribe marks on the frame for all the holes (six for each bracket) needed to mount the "15" and "16" brackets. Remove the brackets and use a 15/32" bit to drill the holes. Clean up any burrs using a file.
- ☐☐ Slide the torsion bars into the lower control arms. Make sure the bars are properly indexed according to the marks made during disassembly.
- ☐ Mount and tighten the "15" bracket using the provided 7/16" x 1-1/4" bolts and related hardware (37 lb-ft).
- ☐☐ [DIAGRAM 8] Loosely install the outside bolts for the "16" bracket and slide the torsion bar crossmember into position as shown using the factory bolts. Install the remaining 7/16" bolts and tighten (37 lb-ft).

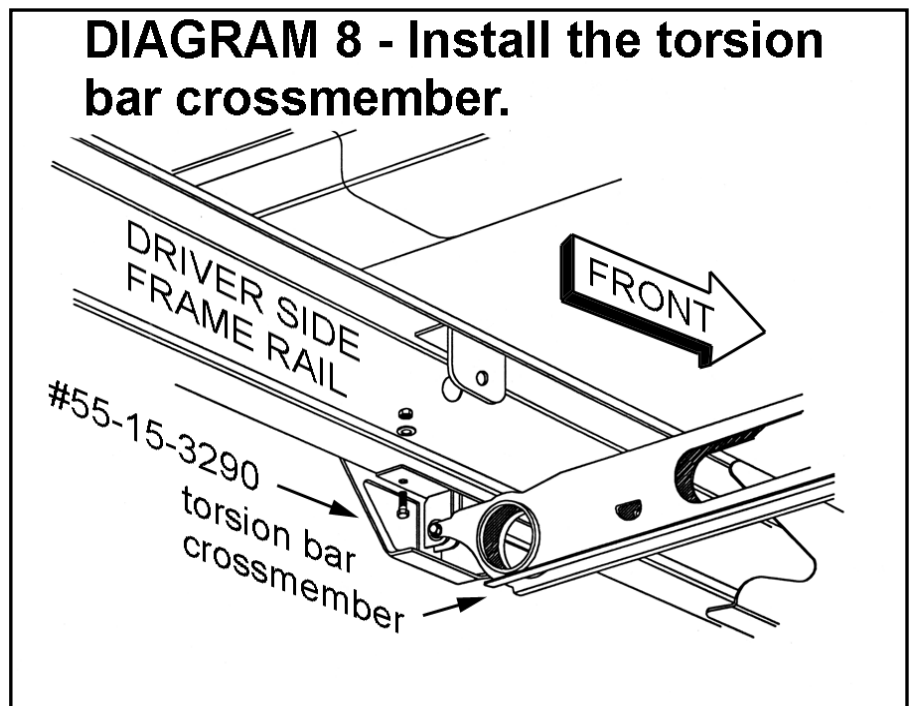

30) LOADING THE TORSION BARS...

- Hold the adjuster arms inside the crossmember and slide each torsion bar back into place. Make sure the bars are properly indexed with the adjusters by following the marks made during disassembly.
- Load the torsion bar using the special tool and reinstall the factory adjusting bolt and nut block. Leave about half of the bolts threads visible below the nut block and unload the tool. Final ride height adjustments will be made once the vehicle is on the ground.

31) TIRES / WHEELS...

- [DIAGRAM 9] Tighten the lug nuts (85 lb-ft) in the sequence shown.

WARNING: When the tires / wheels are installed, always check for and remove any corrosion, dirt, or foreign material on the wheel mounting surface, or anything that contacts the wheel mounting surface (hub, rotor, etc.). Installing wheels without the proper metal-to-metal contact at the wheel mounting surfaces can cause the lug nuts to loosen and the wheel to come off while the vehicle is in motion.

WARNING: Retighten lug nuts at 500 miles after any wheel change, or anytime the lug nuts are loosened. Failure to do so could cause wheels to come off while vehicle is in motion.

DIAGRAM 9- LUG NUT TORQUE SEQUENCE- Use the sequence shown to torque the lug nuts.

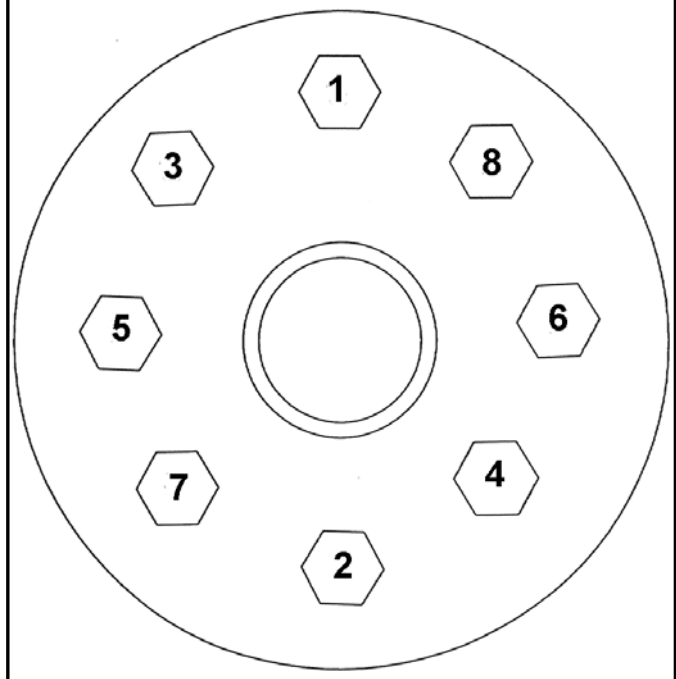
**32) CLEARANCE CHECK...**

- With the vehicle still on jack stands, and the suspension “hanging” at full extension travel, cycle steering lock-to-lock and check all components for proper operation and clearances. Pay special attention to the clearance between the tires / wheels and brake hoses, wiring, etc.
- Lower vehicle to the floor.

33) REAR LIFT...

- The rear lift is purchased separately and has separate instructions. In addition to the steps included with the rear lift, perform the following:
- Remove the factory rear compression travel stops and install the extension brackets (55-19-3290) in the same location with the supplied 7/16” x 1-1/4” bolts and related hardware. Attach the factory compression travel stops to the “19” brackets and tighten.

- Locate the factory rear brake hose bracket mounted to the top of the driver side frame rail. Unclip the brake hose from this bracket and unbolt the bracket from the frame.
- Using the bracket as a template, scribe two marks for new mounting holes at the bottom of the frame. These should be directly below the bracket's original mounting location. Remove the bracket and drill two 5/16" holes. Clean up any burrs with a file.
- Remount the factory brake bracket to the bottom of the frame using the supplied 1/4" x 1" bolts and nyloc nuts. Carefully bend the steel brake line to reach the new bracket location without touching or interfering with other components, then clip the hose back into the bracket.

WARNING: The vehicle is equipped with short cast spacer blocks located between the leaf springs and the axlehousing. These factory blocks must be retained because they seat properly against the axle mounts; the Superlift spacer blocks do not. When using Superlift blocks, install them on top of the factory blocks.

34) ADJUSTING FRONT RIDE HEIGHT...

- Manually bounce the front and rear of the vehicle to normalize the torsion bars and leaf springs.
- On each side, fully tighten the LCA-to-crossmember bolts (156).

- [DIAGRAM 10] Position the vehicle on a level surface. Measure from the LCA front pivot bolt center down to the floor. Record this as Measurement "A".

- Now measure from the inside edge of the knuckle (at the lower ball joint boss) down to the floor. Record this as Measurement "B".

Subtract Measurement "B" from "A" for the ride height figure. Minimum ride height is 4.3"; maximum is 4.8". Ideal ride height is 4.7". Raise height by tightening the torsion bar adjusting bolt; lower height by loosening the bolt. Adjust height 3/8" to 1/2" above the final desired ride height, since the bars will settle slightly after the vehicle is driven.

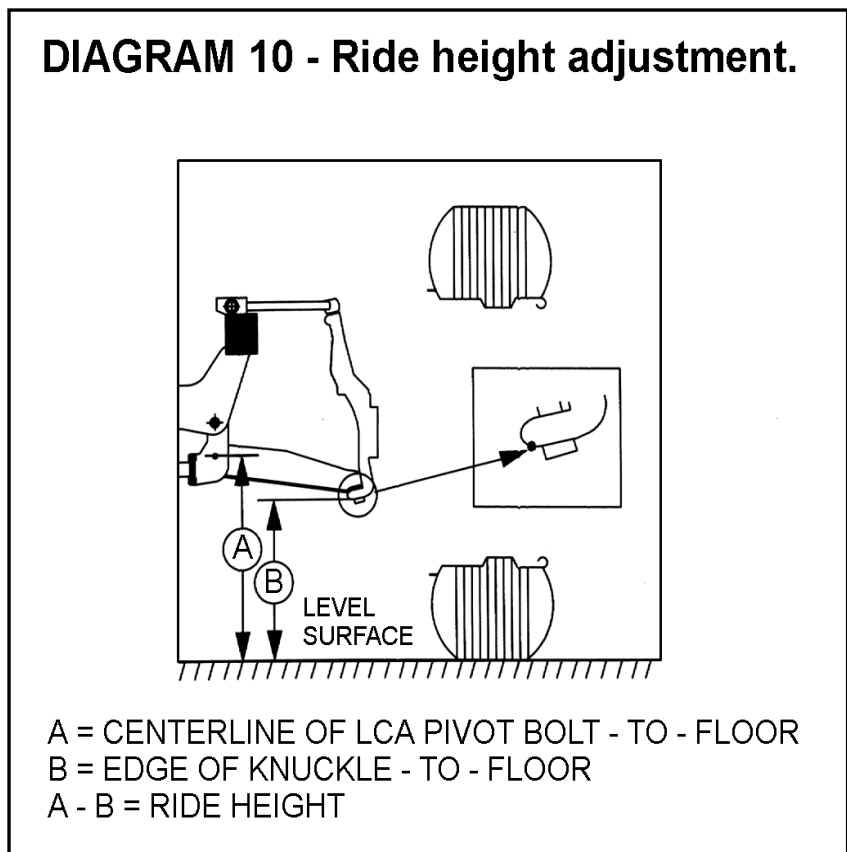

NOTE: Exceeding the stated minimum or maximum heights will cause the suspension to continually “top out” or “bottom out”. This results in a harsh ride, accelerated suspension component wear, and possibly component failure.

35) FINAL CLEARANCE and TORQUE CHECK...

- With vehicle on floor, cycle steering lock-to-lock and inspect the tires / wheels, and the steering, suspension, and brake systems for proper operation, tightness, and adequate clearance.

36) Activate four wheel drive system and check front hubs for engagement

37) HEADLIGHTS...

- Readjust headlights to proper setting.

38) SUPERLIFT NAME BADGE AND WARNING DECAL...

The system includes one 2” x 5” name badge (#0034). Additional and / or larger badges are available from Superlift or a Superlift dealer. We suggest putting the badges on the front fenders, tailgate, or rear window. The badge mounts by means of factory applied, double-backed tape. Follow these instructions to ensure that badge sticks properly:

- Clean designated area with warm, soapy water. Rinse and wipe dry with a soft, lint free towel.
- Thoroughly prep the area with the furnished alcohol wipe pad and wipe dry with a soft, lint free towel. Do not touch the surface again with your hands; they transfer body oils.
- Remove mounting tape backing, line up badge, and press in place. Do not touch mounting tape or allow tape to get dirty.
- Press firmly on the badge face and hold a few seconds to seat mounting tape. A superior adhesive bond forms over time. We recommend allowing 24 hours of cure time before washing and waxing. The emblem itself can be cleaned with any glass cleaner.
- Install the WARNING TO DRIVER decal on the inside of the windshield, or on the dash, within driver’s view. Refer to the “NOTICE TO DEALER AND VEHICLE OWNER” section below.

39) ALIGNMENT...

Realign vehicle to factory specifications. Record the ride height measurement at time of alignment. If, in the future the torsion bars settle excessively, alignment can be restored by adjusting-up the bars to their original ride height.

NOTE: If larger tires / wheels are added after the lift is complete, the truck must be aligned with the new tires and wheels, not the OE tires and wheels.

IMPORTANT PRODUCT USE INFORMATION

As a general rule, the taller a vehicle is, the easier it will roll over. Offset, as much as possible, what is lost in roll over resistance by increasing tire track width. In other words, go “wide” as you go “tall”. Many sportsmen remove their mud tires after winter / hunting season and install ones more appropriate for street driving; always use as wide a tire and wheel combination as possible to enhance vehicle stability.

We strongly recommend, because of roll over possibility, that the vehicle be equipped with a functional roll bar and cage system. Seat belts and shoulder harnesses should be worn at all times. Avoid situations where a side rollover may occur.

Generally, braking performances and capabilities are decreased when significantly larger / heavier tires and wheels are used. Take this into consideration while driving.

Do not add, alter, or fabricate any factory or aftermarket parts to increase vehicle height over the intended height of the Superlift product purchased. Mixing component brands is not recommended.

Most states have some type of law limiting vehicle height. The amount of lift allowed, and how the lift may be achieved, varies greatly. Several states offer exemptions for farm or commercially registered vehicles. It is the owner's responsibility to check state and local laws to ensure that their vehicle will be in compliance.

Superlift makes no claims regarding lifting devices and excludes any and all implied claims. Superlift will not be responsible for any altered product or any improper installation or use of our products.

We will be happy to answer any questions concerning the design, function, and correct use of our products.

IMPORTANT MAINTENANCE INFORMATION

It is the ultimate buyer's responsibility to have all bolts / nuts checked for tightness after the first 100 miles and then every 1000 miles. The steering, suspension and driveline systems, along with wheel alignment should be inspected by a qualified professional mechanic at least every 3000 miles.

NOTICE TO DEALER AND VEHICLE OWNER

Any vehicle equipped with a Superlift lifting device must have the enclosed "Warning to Driver" decal installed on the inside of the windshield or on the vehicle's dash, within driver's view. The "Warning to Driver" decal is to act as a constant safety reminder for whoever may be operating the vehicle. The WARRANTY IS VOID unless this decal is in place. **INSTALLING DEALER...** It is your responsibility to install warning decal and forward these installation instructions to the vehicle owner for review of warnings, product use and maintenance information. Replacement warning decals are available free upon request. These instructions are to be kept with the vehicle registration papers and owners manual for the service life of the vehicle.

SUPERLIFT LIMITED LIFETIME WARRANTY

Suspension products bearing the Superlift (LKI Ent.) name are warranted for as long as the original purchaser owns the vehicle that the LKI product was originally installed on. This warranty is non-transferable. Warranty covers only the product, no labor, time loss, or freight incurred. Any product that has been abused, altered, incorrectly installed, or used in competition is not covered. Product finish, spring bushings, Polyurethane products, and normal wear is not covered. The LKI product is subject to replacement or repair. No other warranties are expressed or implied. An authorized Superlift dealer must inspect the part in question and confirm that the "Warning to Driver" decal is properly displayed. A copy of the sales invoice is required for warranty consideration.