

FLOWMASTER

AMERICAN THUNDER™

MUSCLE TRUCK™

SYSTEM #17398

2004-05 DODGE RAM 1500 TRUCKS

5.7L HEMI V8 ENGINE ONLY

Crew cab/Short bed & Standard cab/Long bed (140" W.B.)

Sport Side Exit Tailpipes

03/01/05

Removal:

- 1) Raise the vehicle and support securely with jack stands.
- 2) To make the removal of the stock system easier, use a 15mm socket and loosen the clamped connection at the rear of the muffler, spray the tailpipe hanger with a lubricant and slide the tailpipe rearward to remove it from the vehicle.
- 3) Support the muffler with a stand and remove the two hangers at the rear of the muffler along with the hangers in front of the muffler from the rubber mounts on the vehicle. Then loosen the clamp at the connection just behind the converters. Once loose, remove the inlet pipe/muffler assembly and set aside.

Installation:

- 1) Place the wire hanger on pipe **#26207** into the rubber mount on the vehicle, then slide the pipe onto the back of the stock inlet pipe, line up the notch in the inlet pipe with the tab on the stock pipe. Place the provided 2 3/4" clamp onto this slip connection and tighten securely.
- 2) Place the provided 3" ring clamp onto the muffler inlet, then slide the muffler **#9530452-176** onto the back of pipe **#26207**, use a stand to support the rear of the muffler
- 3) Place a provided ring clamp onto each of the muffler outlets. Then insert the tailpipe assembly **#16450** into the muffler outlets. Insert the hanger rod on the tailpipe assembly into the rubber mount on the vehicle.
- 4) Make any necessary adjustments to the muffler and pipes so that everything is straight and level. Once everything looks good, go ahead and securely tighten down all of the clamped connections. For a guaranteed no-leak installation we recommend that you go back and weld up all of the connections.

**FLOWMASTER AMERICAN THUNDER
MUSCLE TRUCK SYSTEM #17398
2004-05 DODGE RAM 1500 SERIES TRUCKS
5.7L HEMI ENGINE, 140" W.B. ONLY**

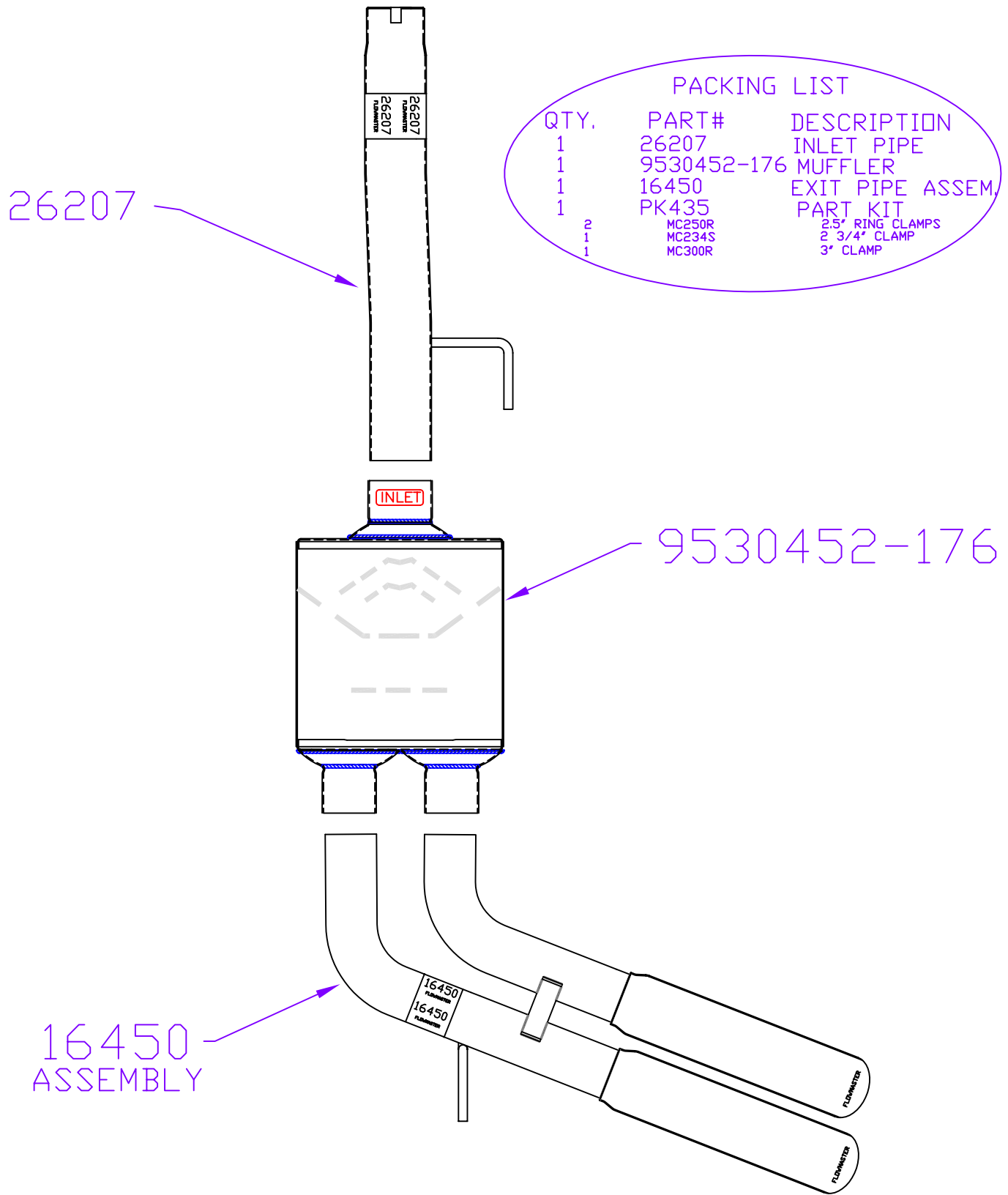

PACKING LIST

QTY.	PART#	DESCRIPTION
1	26207	INLET PIPE
1	9530452-176	MUFFLER
1	16450	EXIT PIPE ASSEM.
1	PK435	PART KIT
2	MC250R	2.5" RING CLAMPS
1	MC234S	2 3/4" CLAMP
1	MC300R	3" CLAMP