

FLOWMASTER™

FORCE II™

SYSTEM #17362

1999-2005 CHEVROLET/GMC, C/K 1500 TRUCKS

143.5" W.B. EXTENDED CAB - SHORT BED, 4.8L & 5.3L ENGINES

April 15,2005

Removal:

1. Raise the vehicle on a rack or on the ground supported with jack stands.
2. Using a hacksaw or sawsall, cut the stock tailpipe off where it exits the muffler. (**This step is not mandatory, but it makes removal a little easier.**)
3. Separate the two wire hangers on the tailpipe from the rubber mounts on the vehicle. If you have cut the tailpipe, remove the tailpipe and set aside at this time.
4. Support the muffler with a stand and separate the wire hanger from the rubber mount in front of the muffler. Then remove the two nuts at the muffler to converter flange connection and lower the exhaust from under the vehicle.

Installation:

1. Place inlet pipe/resonator assembly #15113 into position behind the catalytic converter. Connect the wire hanger to its rubber mount, and re-install the factory nuts onto the flange connection. Check from the side of the vehicle to see that resonator is fairly flat.
2. Connect the inlet of muffler #53056 to the inlet pipe and support the muffler with a stand, then install one of the provided 3" clamps and tighten enough to hold but still allow for adjustment.
3. From the rear of the axle, slide tailpipe #26142 into position over the rear axle and while holding the pipe, place clamp hanger #283HA onto the front of the pipe, then slide the pipe into the muffler outlet. Connect the hanger to the rubber mount on the vehicle. Then slide clamp hanger #278HA onto the rear of the pipe and into the rubber mount on the vehicle. Pipe should be approx. 1" away from the shock when adjusted.
4. Adjust the position of the pipes and muffler to provide a satisfactory fit. **A minimum 3/4" of clearance** around all parts of the system must be maintained; while also keeping suspension travel and vibration in mind. Then place stainless tip #ST429 onto the end of the tailpipe and adjust to the desired location, clamp firmly in place. We highly recommend tack welding the tip to the pipe to prevent possible slippage and loss.
5. Tighten all clamped connections down securely. For a "cleaner" appearance, connections may be welded and the clamps removed. Place the supplied 1/2" hanger keepers onto the end of the inlet pipe and tailpipe hangers, slide them up to the rubber mounts to firmly hold the system in place.

FLOWMASTER FORCE II SYSTEM #17362

1999-2005 CHEVROLET/GMC, C/K 1500 TRUCKS

143.5" W.B. EXTENDED CAB-SHORT BED, 4.8L & 5.3L

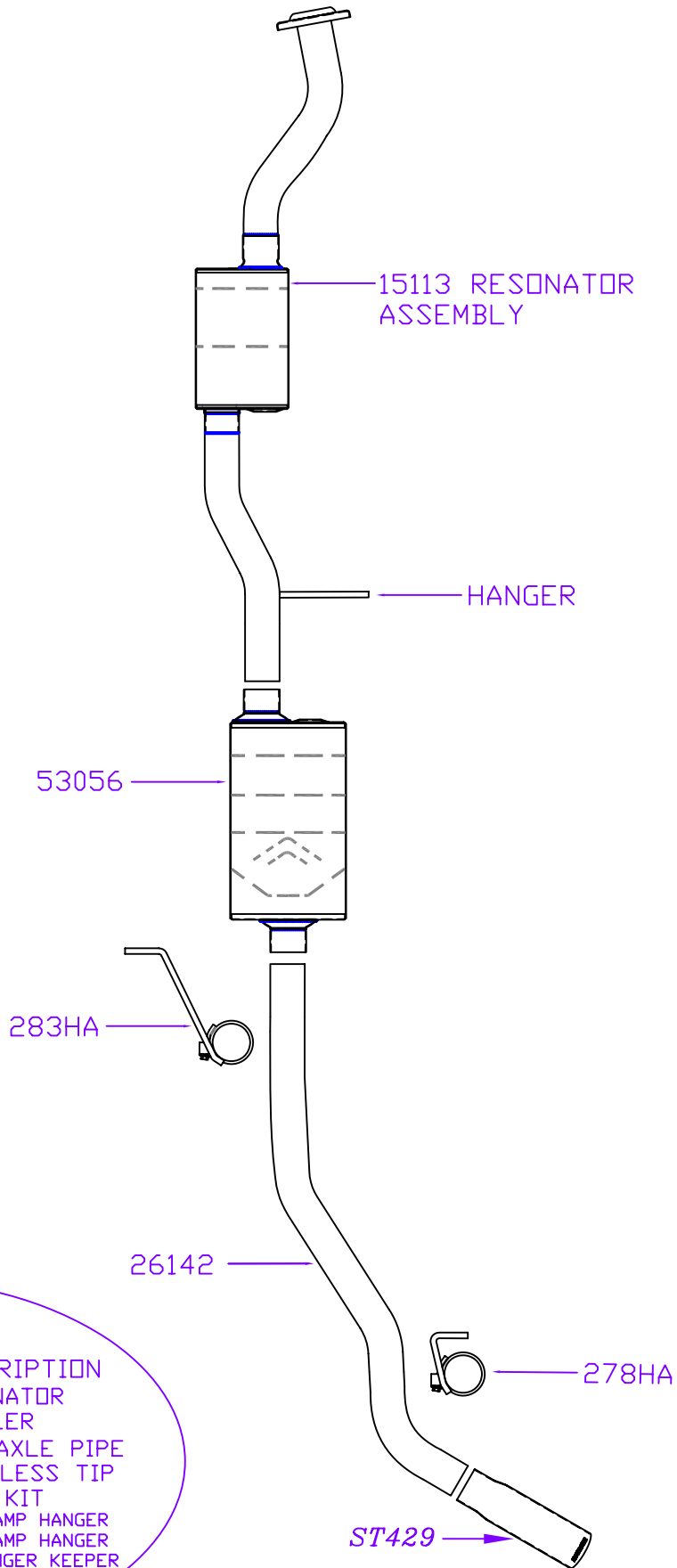

PACKING LIST

QTY.	PART#	DESCRIPTION
1	15113	RESONATOR
1	53056	MUFFLER
1	26142	OVERAXLE PIPE
1	ST429	STAINLESS TIP
1	PK406	PART KIT
1	278HA	CLAMP HANGER
1	283HA	CLAMP HANGER
3	1/2"	HANGER KEEPER
2	MC300G	3" CLAMP