

FLOWMASTER™

FORCE II™

SYSTEM #17328

**2001-04 CHEVY/ GMC 2500HD & 3500 SERIES TRUCKS
FITS ALL EXTENDED CAB AND CREW CAB MODELS
8.1L VORTEC ENGINES**

Removal:

2/9/06

- 1) Raise the vehicle and support with jack stands. Also place a stand under the muffler to support it when the tailpipe and inlet pipes are cut.
- 2) For Extended Cab/Short Bed and Extended Cab/Long Bed models and also the Crew Cab, Long Bed model trucks, use a tape measure and make a mark on both inlet pipes 9" from the muffler end cap. For Crew Cab, Short Bed model trucks, measure 11½" from the muffler end cap and make a mark on both inlet pipes. Cut both the right and left side inlet pipes on the marks you have made. Please be sure to measure twice and cut once to assure the pipes are cut correctly. See the removal and installation diagram for a visual description of this step. Separate the two rubber hangers on the tailpipe from their rubber mounts on the vehicle then lower the muffler and tailpipe from under the vehicle and set aside.
- 3) Prior to cutting the inlet pipes, you may choose to cut the stock tailpipe off at the rear of the muffler. **This step is not mandatory, but it makes the removal of the system a little easier.**
- 4) It may be necessary to debur the inlet pipes to allow smooth installation of the new muffler.

Installation:

- 1) Slip muffler #530503-151 onto the front pipes until the muffler inlets are completely seated on the inlet pipes. (See diagram). On Crew Cab, Short Bed model trucks, place the supplied TB292 adapter pipes onto the inlet pipes in front of the Flowmaster muffler. Use a stand to support the muffler. Slide the hanger welded to the muffler into the rubber mount on the vehicle.
- 2) Install clamp hanger #252HA into the rubber mount above the muffler and place the clamp over the outlet of the muffler, tighten enough to hold, but still allow for adjustment. Then raise tailpipe #36017 into position over the axle, first connect the hanger at the rear of the pipe with the rubber mount on the vehicle, then slide the tailpipe into the outlet of the muffler.
- 3) Adjust the position of muffler and tailpipe to produce a satisfactory fit and adequate clearance. **A minimum clearance of 3/4"** should be maintained around all parts of the system, also keep suspension travel and vibration in mind. **Fully clamp or weld both muffler inlets.**
- 4) Tighten all clamps down securely. For a "cleaner" installation, the pipe connections may be welded rather than clamped.

REMOVAL/ INSTALLATION DIAGRAM FOR KIT #17328

FOR ALL EXTENDED CAB MODELS AND THE CREW CAB/LONG BED MODEL TRUCKS, CUT BOTH INLET PIPES HERE, 9.00" AWAY FROM THE MUFFLER ENDCAP. *CREW CAB/SHORT BED MODELS CUT 11 1/2" FROM THE MUFFLER END CAP.

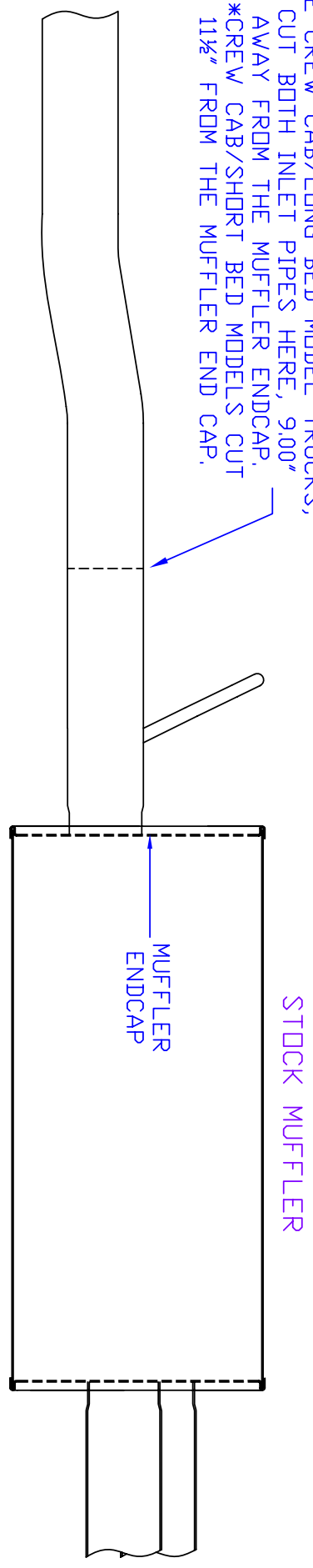

ONCE CUT, SLIDE MUFFLER #530503-151 FULLY DN. CLAMP OR FULLY WELD BOTH PIPES.

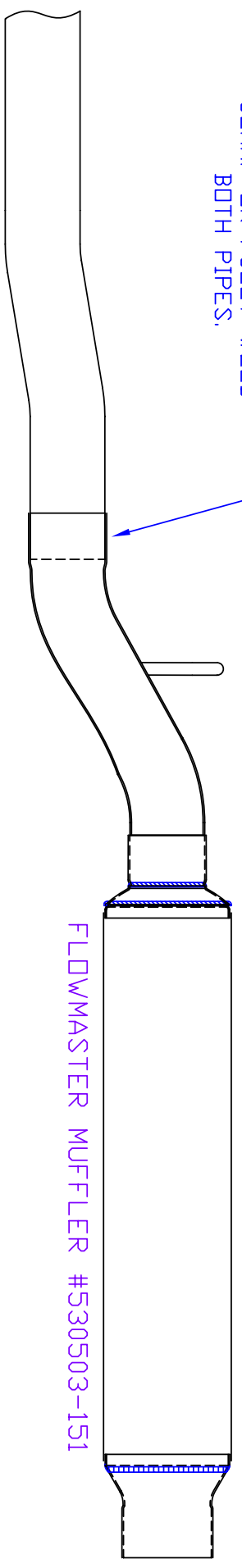

*BE SURE TO PLACE TB292 ADAPTER PIPES BEFORE MUFFLER #530503-151 ON CREW CAB/SHORT BED MODELS.

FLOWMASTER FORCE II SYSTEM #17328
2001-04 CHEVY/GMC 2500HD & 3500 SERIES TRUCKS
FITS ALL EXTENDED CAB AND CREW CAB MODELS
8.1L VORTEC ENGINES

