

FLOWMASTER

AMERICAN THUNDER™

SYSTEM #17325

**1999-02 CHEVROLET/ GMC EXTENDED CAB, SHORT BED TRUCK
2500 WITH VORTEC 6.0L V8 ENGINE - NON HD ONLY**

Removal:

07/09/04

- 1) Raise the vehicle and support with jack stands. Also place a stand under the muffler to support it when the tailpipe and inlet pipes are cut.
- 2) Using a tape measure, measure 3 1/4" from the muffler end cap and make a mark on both inlet pipes. Cut both the right and left side inlet pipes on this mark. See the removal and installation diagram for a visual description of this step. Separate the two rubber hangers on the tailpipe from their rubber mounts on the vehicle then lower the muffler and tailpipe from under the vehicle and set aside.
- 3) Prior to cutting the inlet pipes, you may choose to cut the stock tailpipe off at the rear of the muffler. **This step is not mandatory, but it makes the removal of the system a little easier.**
- 4) It may be necessary to debur the inlet pipes to allow smooth installation of the new muffler.

Installation:

- 1) Slip muffler #530513-148 onto the front pipes until the muffler inlets are completely seated on the inlet pipes. (See diagram). Use a stand to support the muffler. Place clamp hanger #251HA onto the right side inlet pipe and slide hanger into the rubber mount on the vehicle.
- 2) Raise pipe #26130 into position over the axle, first connect the hanger at the rear of the pipe with the rubber mount on the vehicle, then slide the tailpipe into the outlet of the muffler and connect the front hanger. Install the 3" clamp provided onto the muffler outlet, tighten enough to hold, but still allow for adjustment.
- 3) Take stainless tip #ST429 and slide it over the end of the tailpipe. Adjust the rotation and length to your satisfaction then tighten clamp enough to hold but allow for adjustment.
- 4) Adjust the position of muffler and tailpipe to produce a satisfactory fit and adequate clearance. **A minimum clearance of 3/4"** should be maintained around all parts of the system, also keep suspension travel and vibration in mind. **Fully clamp or weld both muffler inlets.**
- 5) Tighten all clamps down securely. For a "cleaner" installation, the pipe connections may be welded rather than clamped.
- 6) Using the four band clamps provided, secure the heat shield to the top of the muffler body. Tighten down clamps securely using an 8mm socket wrench or standard screwdriver. Then, place the supplied 1/2" hanger keepers onto the ends of the muffler and tailpipe hangers, slide them up to the rubber mounts to firmly hold the system in place.

REMOVAL / INSTALLATION DIAGRAM FOR KIT #17325

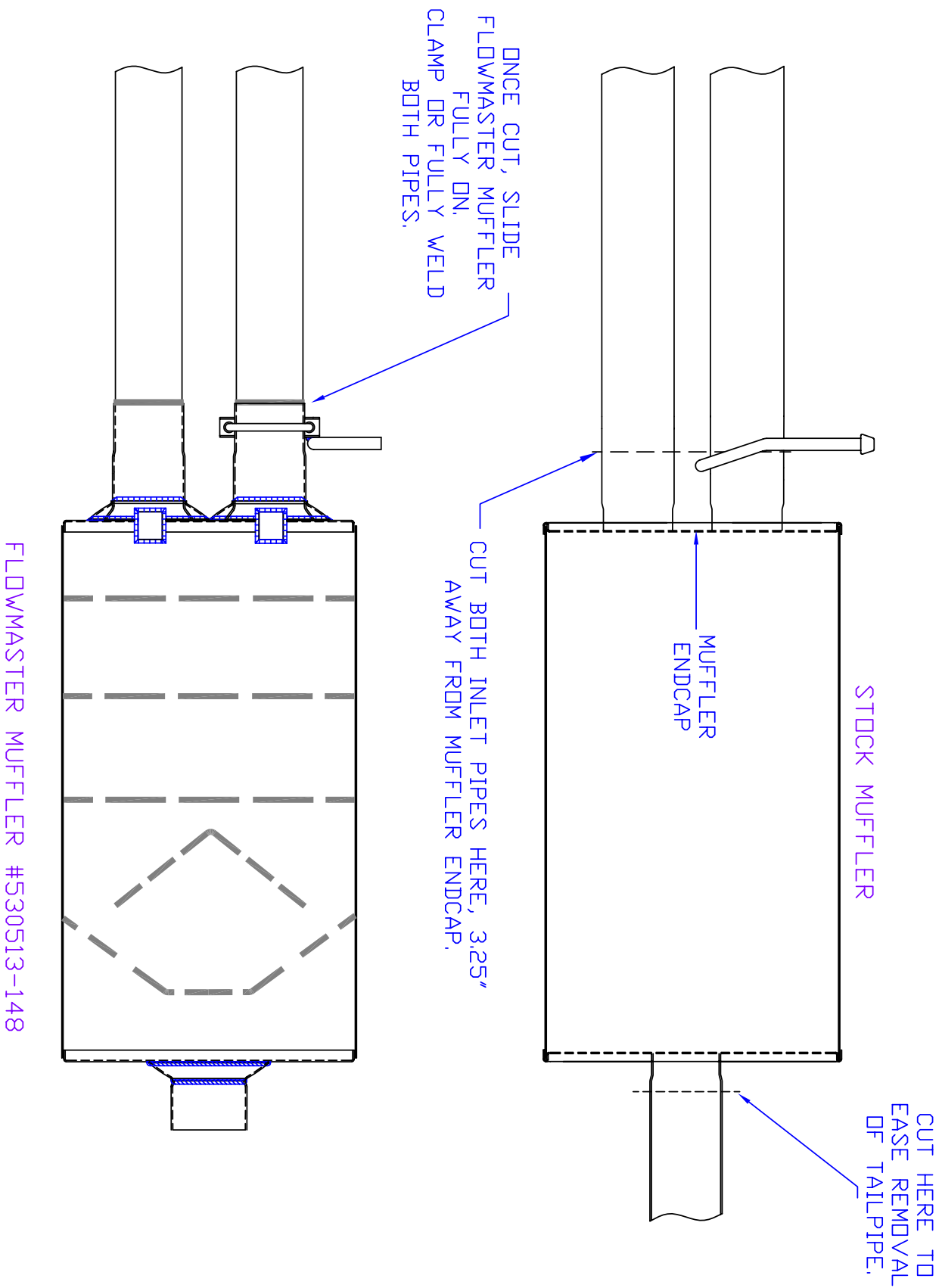

FLOWMASTER AMERICAN THUNDER SYSTEM #17325
 1999-02 CHEVROLET/GMC EXTENDED CAB/SHORT BED TRUCK
 2500 WITH VORTEC 6000 V8 ENGINE - NON HD ONLY

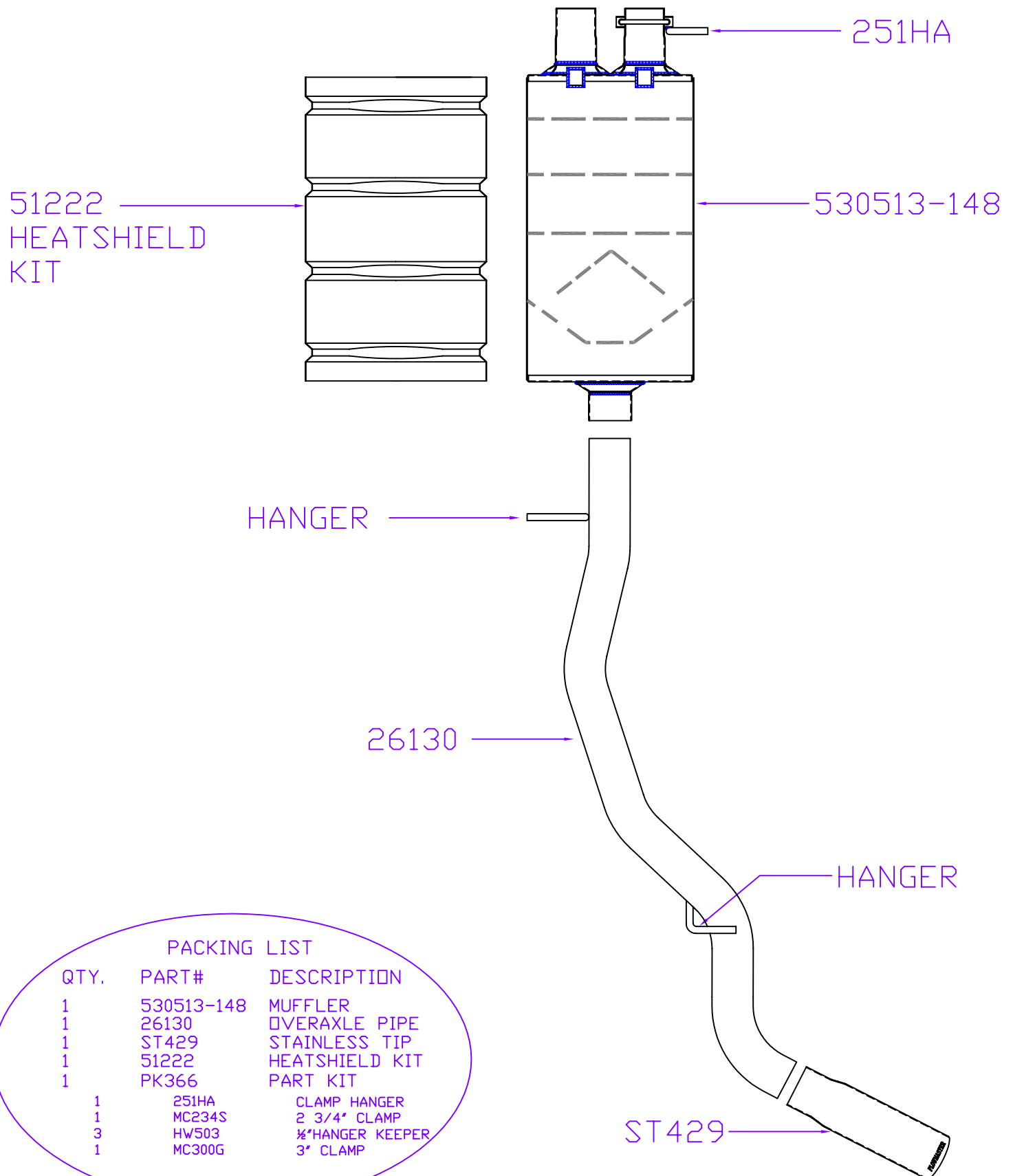

PACKING LIST

QTY.	PART#	DESCRIPTION
1	530513-148	MUFFLER
1	26130	OVERAXLE PIPE
1	ST429	STAINLESS TIP
1	51222	HEATSHIELD KIT
1	PK366	PART KIT
1	251HA	CLAMP HANGER
1	MC234S	2 3/4" CLAMP
3	HW503	1/2" HANGER KEEPER
1	MC300G	3" CLAMP