

FLOWMASTER™

AMERICAN THUNDER™

SYSTEM # 17273
1964½ - 1966 FORD MUSTANG
(DOES NOT FIT CONVERTIBLES)

Removal:

- 1) Raise the rear of the vehicle and support securely with jack stands.
- 2) Remove existing system from the header collector or manifold down pipes back.
- 3) The rear seat of the vehicle will have to be removed in order to install the hangers Described in step 2.

Installation:

- 1) Look on the underside of the vehicle on the back side of the rear seat pan. Measure from the frame in towards the center of the car $6\frac{3}{4}$ " and make a mark. Then measure from the seam on the back of the seats down along your mark from the frame. Make a mark for your first hole $\frac{3}{4}$ " down and then make a mark for your second hole $3\frac{1}{2}$ " down. Re-check the marks to confirm that they are $6\frac{3}{4}$ " from the frame. Center punch both marks and drill them out to a $\frac{3}{8}$ " hole. These measurements will be the same on both sides. (Note: See diagram 1 on page 3 of these instructions.)
- 2) Take the stud plate #244HA and push them from the inside of the vehicle into the holes you have just drilled. Take hanger assembly #230HA for the left side and hanger assembly #229HA for the right side and place them over the two bolts protruding through the floor, secure the hangers to the body using the $\frac{3}{8}$ " nuts and lock washers provided.
- 3) After mounting the hangers into place, slide the rubber hanger #HA168 onto the hangers. Place the clamp hanger #209HA into the bottom hole of the rubber hanger (both sides take the same clamp hanger.) Both clamp hangers will point towards the center of the vehicle.
- 4) On the frame at the rear of the vehicle there is either a flat plate bolted to the frame or just two holes punched in the frame. Unbolt the flat plate if it is there, take hanger #231HA for the right side and hanger #232HA for the left side and mount them in those holes. You can bolt the plate on top of the hangers if you want. Make sure the welded hanger rod is towards the front of the vehicle. Use $\frac{7}{16}$ " x $2\frac{1}{2}$ " bolt, $\frac{7}{16}$ " flat washer, $\frac{7}{16}$ " lock washer and $\frac{7}{16}$ " nut, also place backing plate #HA313 on outside of frame for extra support when bolting hangers to frame on the rear of the vehicle.

- 5) After mounting the rear hangers in place, slide the rubber hanger #HA168 onto the hangers. Place the right tailpipe #16271 over the rear axle and so that the rear of the tailpipe exits between the fuel tank and the leaf spring. Slide the tailpipe hanger through the rubber hanger attached to the frame. Do the same for the left tailpipe #16272.
- 6) Install the left muffler #942541 by placing the outlet of the muffler into the clamp hanger #209HA, rotate the muffler to get it level and support with a stand. Tighten the clamp/hanger enough to hold the muffler in place but still allow for adjustment.
- 7) Install the right muffler #942541 by placing the outlet of the muffler into the camp of the hanger #209HA, rotate the muffler to get it level and support with a stand. Tighten the clamp/hanger enough to hold the muffler in place but still allow for adjustment.
- 8) Slide the front of the right tailpipe #16271 through the hanger #209HA and into the rear of the muffler. Repeat for the left side tailpipe #16272.
- 9) Adjust the rear of the tailpipes so that the angle cut is rotated correctly and is centered between the gas tank and the leaf spring. Repeat this step for both sides of the vehicle.
- 10) Install the front H-pipe assembly #16257 by placing the rear of the front pipe assembly into the inlets of both mufflers and centering it in the drive line cavity. Support the front of the assembly with a stand, be sure that the muffler and front pipe assembly are level. Once the mufflers and front pipe assembly are in place, check the hangers at the rear of each muffler to see if they are hanging straight down, adjust the front pipe and the mufflers forward or back as needed to get the correct fit. Once the desired fit is achieved, place a 2½" clamp onto the inlet of each muffler, tighten enough to hold in place but still allow for adjustment.
- 11) It will be necessary to adapt from your existing headers or manifold downpipes to the Flowmaster H-pipe assembly, due to the many different variables in header/manifold down pipe locations the pieces required to do this are not included in this kit.
- 12) Remove temporary support and allow the system to suspend on the hangers.
- 13) Adjust and align all the pipes, a minimum of ½" clearance between the new Flowmaster exhaust system and the chassis, drivetrain components, brake lines and fuel lines. Also keep suspension travel in mind.
- 14) Once all adjustments are made, tighten all connections and clamps. After the hangers are adjusted to their final position, place the provided hanger keepers onto the end of all the hanger rods above the mufflers and the hangers that support the tailpipes. This will keep the hangers from slipping out of the rubber mounts.

NOTE: FLOWMASTER RECOMMENDS WELDING ALL SLIP FIT CONNECTIONS.

PACKING LIST FOR 17273

<u>QUANTITY</u>	<u>DESCRIPTION</u>	<u>PART NUMBER</u>
2	Muffler	942541
1	H-pipe Assembly	16257
1	Right Tailpipe	16271
1	Left Tailpipe	16272
1	Parts Kit	PK350
2	Muffler Hanger	209HA
1	Top Right muffler Hanger	229HA
1	Top Left Muffler hanger	230HA
1	Right Tailpipe Hanger	231HA
1	Left Tailpipe Hanger	232HA
2	Muffler Mounting Plate	244HA
4	2½" Clamp	MC250S
4	Rubber Hanger	HA168
8	7/16" Hanger Keepers	
2	Backing Plates	HA313
4	7/16" x 2½" Bolts	
4	7/16" Nuts	
4	7/16" Flat Washers	
4	7/16" Lock Washers	
4	3/8" Nuts	
4	3/8" Lock Washers	

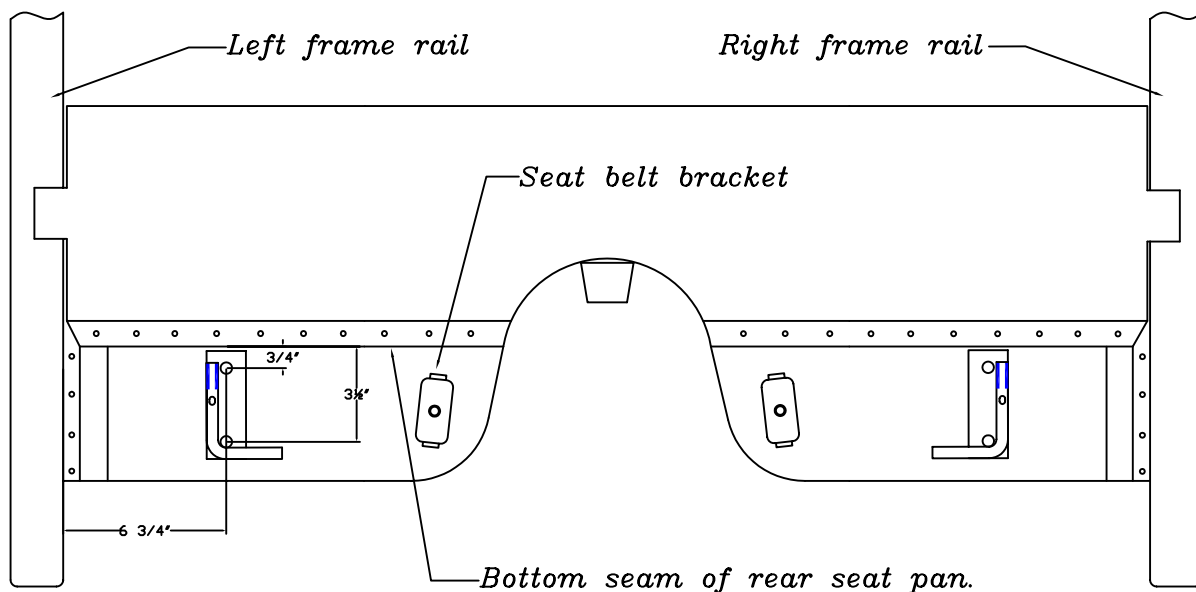

Diagram of installation step 1.

*FLOWMASTER AMERICAN THUNDER SYSTEM #17273
1964½-66 FORD MUSTANG
(DOES NOT FIT CONVERTIBLES)*

